

# Project Specific Water Quality Management Plan

A Template for Projects located within the **Santa Ana Watershed** Region of Riverside County

**Project Title:** Moreno Valley Commercial Center

**Development No:** PEN21-0273

**Design Review/Case No:** LWQ21-0062

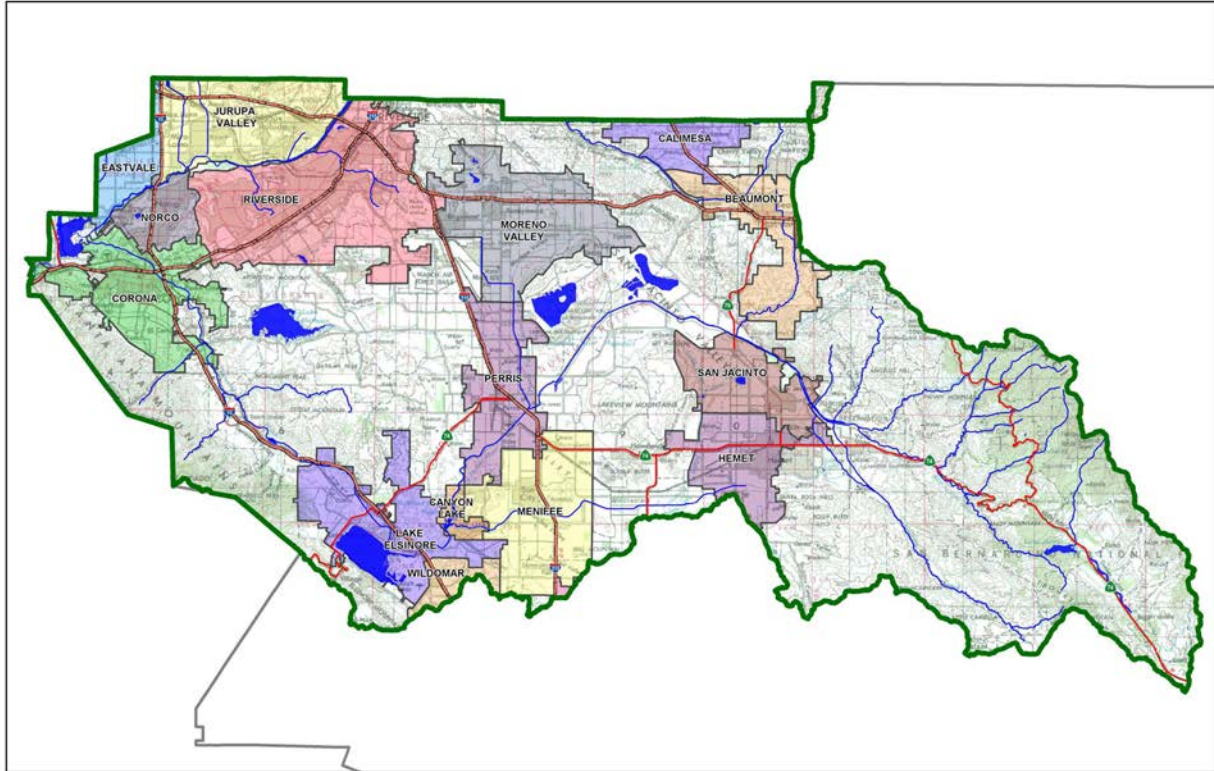

- Preliminary
- Final

**Original Date Prepared:** 05/15/2020

**Revision Date(s):** 09/21/2020, 09/02/2021, 12/15/2021,  
05/13/2022, 07/27/2022

*Prepared for Compliance with  
Regional Board Order No. **R8-2010-0033***

**Template revised June 30, 2016**

**Spring 2019 WQMP Training Update**

## Contact Information:

### Prepared for:

Empire Design Group, Inc.  
24861 Washington Avenue  
Murrieta, CA 92562  
Gregory Hann, President

### Prepared by:

Plump Engineering, Inc.,  
914 E. Katella Avenue,  
Anaheim, CA 92805,  
Troy Tryfonopoulos PE, Director of  
Civil Engineering  
(714) 385-1835

## A Brief Introduction

This Project-Specific WQMP Template for the **Santa Ana Region** has been prepared to help guide you in documenting compliance for your project. Because this document has been designed to specifically document compliance, you will need to utilize the WQMP Guidance Document as your “how-to” manual to help guide you through this process. Both the Template and Guidance Document go hand-in-hand, and will help facilitate a well prepared Project-Specific WQMP. Below is a flowchart for the layout of this Template that will provide the steps required to document compliance.

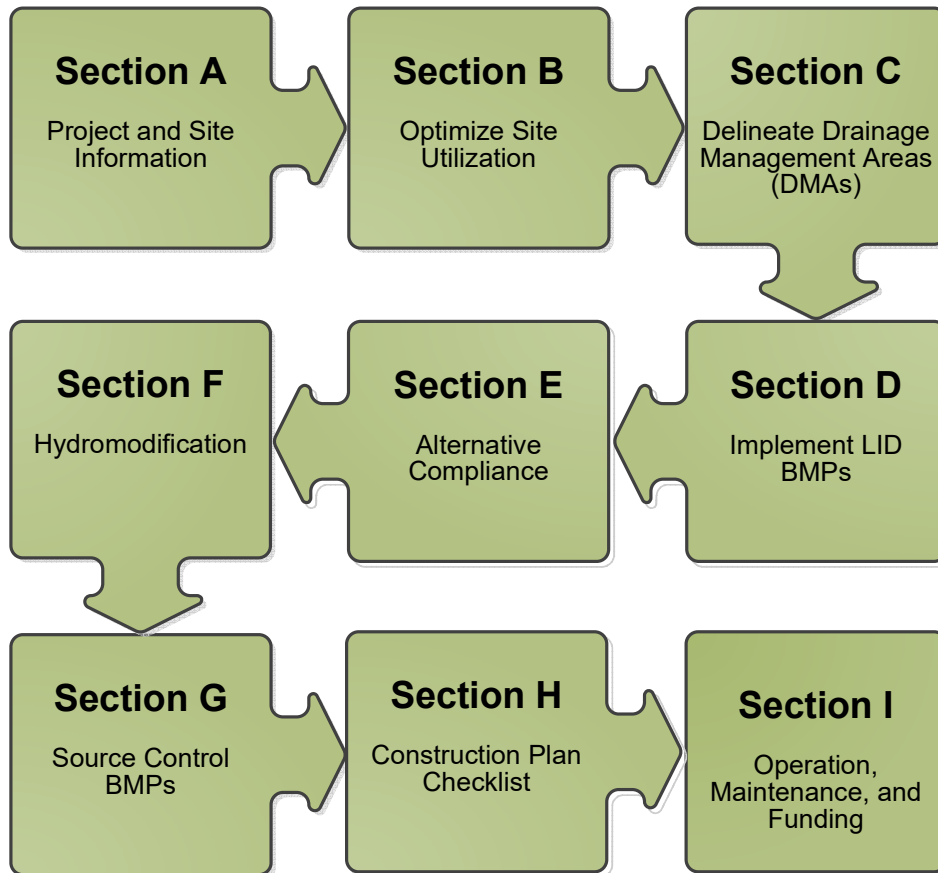

## OWNER'S CERTIFICATION

This Project-Specific Water Quality Management Plan (WQMP) has been prepared for Empire Design Group by Plump Engineering Inc. for the Moreno Valley Commercial Center project.

This WQMP is intended to comply with the requirements of City of Moreno Valley for Ordinance 827 which includes the requirement for the preparation and implementation of a Project-Specific WQMP.

The undersigned, while owning the property/project described in the preceding paragraph, shall be responsible for the implementation and funding of this WQMP and will ensure that this WQMP is amended as appropriate to reflect up-to-date conditions on the site. In addition, the property owner accepts responsibility for interim operation and maintenance of Stormwater BMPs until such time as this responsibility is formally transferred to a subsequent owner. This WQMP will be reviewed with the facility operator, facility supervisors, employees, tenants, maintenance and service contractors, or any other party (or parties) having responsibility for implementing portions of this WQMP. At least one copy of this WQMP will be maintained at the project site or project office in perpetuity. The undersigned is authorized to certify and to approve implementation of this WQMP. The undersigned is aware that implementation of this WQMP is enforceable under City of Moreno Valley Water Quality Ordinance (Municipal Code Section Chapter 8.10).

"I, the undersigned, certify under penalty of law that the provisions of this WQMP have been reviewed and accepted and that the WQMP will be transferred to future successors in interest."

  
\_\_\_\_\_  
Owner's Signature

07/27/2022  
\_\_\_\_\_  
Date

Danny Singh  
\_\_\_\_\_  
Owner's Printed Name

Owner  
\_\_\_\_\_  
Owner's Title/Position

## PREPARER'S CERTIFICATION

"The selection, sizing and design of stormwater treatment and other stormwater quality and quantity control measures in this plan meet the requirements of Regional Water Quality Control Board Order No. **R8-2010-0033** and any subsequent amendments thereto."

  
\_\_\_\_\_  
Preparer's Signature

7/27/2022  
\_\_\_\_\_  
Date

Troy Tryfonopoulos, PE  
\_\_\_\_\_  
Preparer's Printed Name

Director of Civil Engineering  
\_\_\_\_\_  
Preparer's Title/Position

Preparer's Licensure:



## Table of Contents

Section A: Project and Site Information.....	6
A.1 Maps and Site Plans.....	6
A.2 Identify Receiving Waters.....	7
A.3 Additional Permits/Approvals required for the Project: .....	7
Section B: Optimize Site Utilization (LID Principles) .....	8
Section C: Delineate Drainage Management Areas (DMAs).....	10
Section D: Implement LID BMPs .....	12
D.1 Infiltration Applicability .....	12
D.2 Harvest and Use Assessment.....	13
D.3 Bioretention and Biotreatment Assessment .....	15
D.4 Feasibility Assessment Summaries .....	16
D.5 LID BMP Sizing .....	17
Section E: Alternative Compliance (LID Waiver Program) .....	22
E.1 Identify Pollutants of Concern .....	23
E.2 Stormwater Credits .....	24
E.3 Sizing Criteria.....	24
E.4 Treatment Control BMP Selection .....	25
Section F: Hydromodification .....	26
F.1 Hydrologic Conditions of Concern (HCOC) Analysis.....	26
F.2 HCOC Mitigation.....	27
Section G: Source Control BMPs.....	28
Section H: Construction Plan Checklist .....	32
Section I: Operation, Maintenance and Funding.....	33

## List of Tables

Table A.1 Identification of Receiving Waters.....	7
Table A.2 Other Applicable Permits.....	7
Table C.1 DMA Classifications.....	10
Table C.2 Type 'A', Self-Treating Areas.....	10
Table C.3 Type 'B', Self-Retaining Areas.....	10
Table C.4 Type 'C', Areas that Drain to Self-Retaining Areas.....	11
Table C.5 Type 'D', Areas Draining to BMPs.....	11
Table D.1 Infiltration Feasibility.....	12
Table D.2 LID Prioritization Summary Matrix.....	16
Table D.3 DCV Calculations for LID BMPs.....	17
Table E.1 Potential Pollutants by Land Use Type.....	23
Table E.2 Water Quality Credits.....	24
Table E.3 Treatment Control BMP Sizing.....	24
Table E.4 Treatment Control BMP Selection.....	25
Table F.1 Hydrologic Conditions of Concern Summary.....	26
Table G.1 Permanent and Operational Source Control Measures.....	28
Table H.1 Construction Plan Cross-reference.....	32

## List of Appendices

Appendix 1: Maps and Site Plans.....	34
Appendix 2: Construction Plans.....	36
Appendix 3: Soils Information.....	37
Appendix 4: Historical Site Conditions.....	38
Appendix 5: LID Infeasibility.....	39
Appendix 6: BMP Design Details.....	40
Appendix 7: Hydromodification.....	41
Appendix 8: Source Control.....	42
Appendix 9: O&M.....	43
Appendix 10: Educational Materials.....	- 6 -

## Section A: Project and Site Information

PROJECT INFORMATION	
Type of Project:	Commercial
Planning Area:	Commercial/MUN (Mixed Use Neighborhood)
Community Name:	Moreno Valley
Development Name:	Moreno Valley Commercial Center
PROJECT LOCATION	
Latitude & Longitude (DMS): 33.918380, -117.210085	
Project Watershed and Sub-Watershed: Santa Ana Watershed, San Jacinto River Sub-watershed	
APN(s): 479-631-010	
Map Book and Page No.: Book 11, page 10 of maps, Records of Riverside County, CA	
PROJECT CHARACTERISTICS	
Proposed or Potential Land Use(s)	Commercial
Proposed or Potential SIC Code(s)	5541-Gas Station, 5812-Restaurant, 7542-Car Wash, 6512-Office Building
Area of Impervious Project Footprint (SF)	353,927
Total Area of <u>proposed</u> Impervious Surfaces within the Project Limits (SF)/or Replacement	353,927
Does the project consist of offsite road improvements?	<input checked="" type="checkbox"/> Y <input type="checkbox"/> N
Does the project propose to construct unpaved roads?	<input type="checkbox"/> Y <input checked="" type="checkbox"/> N
Is the project part of a larger common plan of development (phased project)?	<input type="checkbox"/> Y <input checked="" type="checkbox"/> N
EXISTING SITE CHARACTERISTICS	
Total area of <u>existing</u> Impervious Surfaces within the project limits (SF)	0
Is the project located within any MSHCP Criteria Cell?	<input type="checkbox"/> Y <input checked="" type="checkbox"/> N
If so, identify the Cell number:	N/A
Are there any natural hydrologic features on the project site?	<input type="checkbox"/> Y <input checked="" type="checkbox"/> N
Is a Geotechnical Report attached?	<input checked="" type="checkbox"/> Y <input type="checkbox"/> N
If no Geotech. Report, list the NRCS soils type(s) present on the site (A, B, C and/or D)	C
What is the Water Quality Design Storm Depth for the project?	0.65

### A.1 Maps and Site Plans

When completing your Project-Specific WQMP, include a map of the local vicinity and existing site. In addition, include all grading, drainage, landscape/plant palette and other pertinent construction plans in Appendix 2. At a **minimum**, your WQMP Site Plan should include the following:

- Drainage Management Areas
- Proposed Structural BMPs
- Drainage Path
- Drainage Infrastructure, Inlets, Overflows
- Source Control BMPs
- Buildings, Roof Lines, Downspouts
- Impervious Surfaces
- Standard Labeling

Use your discretion on whether or not you may need to create multiple sheets or can appropriately accommodate these features on one or two sheets. Keep in mind that the Co-Permittee plan reviewer must be able to easily analyze your project utilizing this template and its associated site plans and maps.

## A.2 Identify Receiving Waters

Using Table A.1 below, list in order of upstream to downstream, the receiving waters that the project site is tributary to. Continue to fill each row with the Receiving Water's 303(d) listed impairments (if any), designated beneficial uses, and proximity, if any, to a RARE beneficial use. Include a map of the receiving waters in Appendix 1.

**Table A.1** Identification of Receiving Waters

Receiving Waters	EPA Approved 303(d) List Impairments	Designated Beneficial Uses	Proximity to RARE Beneficial Use
Kitching Street Channel	None	None	Not a waterbody classified as RARE
Perris Valley Channel	None	None	Not a waterbody classified as RARE
San Jacinto River Reach 3	None	AGR, GWR, REC1, REC2, WARM, WILD	Not a waterbody classified as RARE
San Jacinto River Reach 2 Canyon Lake (Railroad Canyon Reservoir)	Nutrients	AGR, GWR, REC1, REC2, WARM, WILD	Not a waterbody classified as RARE
Lake Elsinore	Nutrients, DDT, Organic Enrichment/low Dissolved Oxygen, PCBs, Toxicity	REC1, REC2, WARM, WILD	Not a waterbody classified as RARE

## A.3 Additional Permits/Approvals required for the Project:

**Table A.2** Other Applicable Permits

Agency	Permit Required	
State Department of Fish and Game, 1602 Streambed Alteration Agreement	<input type="checkbox"/> Y	<input checked="" type="checkbox"/> N
State Water Resources Control Board, Clean Water Act (CWA) Section 401 Water Quality Cert.	<input type="checkbox"/> Y	<input checked="" type="checkbox"/> N
US Army Corps of Engineers, CWA Section 404 Permit	<input type="checkbox"/> Y	<input checked="" type="checkbox"/> N
US Fish and Wildlife, Endangered Species Act Section 7 Biological Opinion	<input type="checkbox"/> Y	<input checked="" type="checkbox"/> N
Statewide Construction General Permit Coverage	<input checked="" type="checkbox"/> Y	<input type="checkbox"/> N
Statewide Industrial General Permit Coverage	<input type="checkbox"/> Y	<input checked="" type="checkbox"/> N
Western Riverside MSHCP Consistency Approval (e.g., JPR, DBESP)	<input type="checkbox"/> Y	<input checked="" type="checkbox"/> N
Other (please list in the space below as required) Grading Permit, Building Permit	<input checked="" type="checkbox"/> Y	<input type="checkbox"/> N

If yes is answered to any of the questions above, the Co-Permittee may require proof of approval/coverage from those agencies as applicable including documentation of any associated requirements that may affect this Project-Specific WQMP.

## Section B: Optimize Site Utilization (LID Principles)

Review of the information collected in Section 'A' will aid in identifying the principal constraints on site design and selection of LID BMPs as well as opportunities to reduce imperviousness and incorporate LID Principles into the site and landscape design. For example, **constraints** might include impermeable soils, high groundwater, groundwater pollution or contaminated soils, steep slopes, geotechnical instability, high-intensity land use, heavy pedestrian or vehicular traffic, utility locations or safety concerns. **Opportunities** might include existing natural areas, low areas, oddly configured or otherwise unbuildable parcels, easements and landscape amenities including open space and buffers (which can double as locations for bioretention BMPs), and differences in elevation (which can provide hydraulic head). Prepare a brief narrative for each of the site optimization strategies described below. This narrative will help you as you proceed with your LID design and explain your design decisions to others.

The 2010 Santa Ana MS4 Permit further requires that LID Retention BMPs (Infiltration Only or Harvest and Use) be used unless it can be shown that those BMPs are infeasible. Therefore, it is important that your narrative identify and justify if there are any constraints that would prevent the use of those categories of LID BMPs. Similarly, you should also note opportunities that exist which will be utilized during project design. Upon completion of identifying Constraints and Opportunities, include these on your WQMP Site plan in Appendix 1.

### Site Optimization

The following questions are based upon Section 3.2 of the WQMP Guidance Document. Review of the WQMP Guidance Document will help you determine how best to optimize your site and subsequently identify opportunities and/or constraints, and document compliance.

Did you identify and preserve existing drainage patterns? If so, how? If not, why?

*The existing condition is a vacant undeveloped lot with some vegetation throughout the property. The site will be fully developed for commercial use. The new development will consist of two (2) offices (9,900 SF), Two (2) retail buildings (3,200 SF), one (1) bank (3,775 SF), two (2) restaurants with drive thru (6,640 SF), one (1) restaurant with patio (7,250 SF), one (1) gas station with canopy, express car wash, and store (14,915 SF). The drainage pattern for the south side of the property will mostly remain the same as the existing condition. The drainage pattern to the north of the property will be adjusted. Run-off from the site will be treated by the infiltration trenches on the north and south side of the property. Overflow from the infiltration trenches will discharge to the curb and gutter on Alessandro Blvd as well as Timo Street.*

*This project proposes off-site street improvements as well. These street improvement areas will have it water treated by the proposed infiltration trenches as well.*

Did you identify and protect existing vegetation? If so, how? If not, why?

*The existing site is undeveloped land covered with grass, and brush. The entire area of the new development will be disturbed, removing existing vegetation. The proposed project shall include drought tolerant landscaping.*

Did you identify and preserve natural infiltration capacity? If so, how? If not, why?



*The existing infiltration rate of the site is 1.60 in/hr per the soils report (Appendix 3). Based on the measured infiltration rate, infiltration is feasible for the site. Infiltration trenches will be used to treat the stormwater runoff.*

Did you identify and minimize impervious area? If so, how? If not, why?

*Roughly 20% of the project site will be developed for landscaping. The infiltration trenches and basins will be placed within the proposed landscape area. The infiltration system shall be designed to retain and treat a designated volume of stormwater runoff.*

Did you identify and disperse runoff to adjacent pervious areas? If so, how? If not, why?

*The proposed grading and drainage are designed to maintain a similar flow pattern to the existing condition. Drainage from the site is broken up into two (2) drainage management areas (DMA). Landscaping along the west side of the property will be graded to prevent drainage to the adjacent properties. The proposed drainage pattern will direct runoff to the proposed stormwater treatment BMPs. The infiltration trench to treat DMA-1 is located along the northwest corner of the property. The infiltration trench to treat DMA-2 is located along the south side of the property. Overflow from the south infiltration trench will be directed to the curb and gutter on Alessandro Boulevard and the north infiltration trench will drain to Timo Street.*

*The DMA's also accounts for the off-site street improvements for this project. Off-site flows will flow into catch basins located along Alessandro Boulevard and Timo St. which will then take the storm water to the infiltration trenches on-site.*

## Section C: Delineate Drainage Management Areas (DMAs)

Utilizing the procedure in Section 3.3 of the WQMP Guidance Document which discusses the methods of delineating and mapping your project site into individual DMAs, complete Table C.1 below to appropriately categorize the types of classification (e.g., Type A, Type B, etc.) per DMA for your project site. Upon completion of this table, this information will then be used to populate and tabulate the corresponding tables for their respective DMA classifications.

**Table C.1 DMA Classifications**

DMA Name or ID	Surface Type(s) <sup>1</sup>	Area (Sq. Ft.)	DMA Type
DMA 1	Mixed Surface Types	135,761 SF	D
DMA 2	Mixed Surface Types	211,500 SF	D
DMA 3 (off-site, ALESSANDRO BLVD./LASSELLE ST.)	Mixed Surface Types	81,584 SF	D
DMA 4 (off-site, TIMO ST.)	Mixed Surface Types	17,614 SF	D

<sup>1</sup>Reference Table 2-1 in the WQMP Guidance Document to populate this column

**Table C.2 Type 'A', Self-Treating Areas**

DMA Name or ID	Area (Sq. Ft.)	Stabilization Type	Irrigation Type (if any)
N/A			

**Table C.3 Type 'B', Self-Retaining Areas**

Self-Retaining Area				Type 'C' DMAs that are draining to the Self-Retaining Area		
DMA Name/ ID	Post-project surface type	Area (square feet)	Storm Depth (inches)	DMA Name / ID	[C] from Table C.4	Required Retention Depth (inches)
		[A]	[B]		= [C]	
N/A						

$$[D] = [B] + \frac{[B] \cdot [C]}{[A]}$$

**Table C.4 Type 'C', Areas that Drain to Self-Retaining Areas**

DMA					Receiving Self-Retaining DMA		
DMA Name/ ID	Area (square feet)	Post-project surface type	Runoff factor	Product	DMA name /ID	Area (square feet)	Ratio
	[A]		[B]	[C] = [A] x [B]		[D]	[C]/[D]
N/A							

**Table C.5 Type 'D', Areas Draining to BMPs**

DMA Name or ID	BMP Name or ID
DMA 1	INFILTRATION TRENCH, INF-1
DMA 2	INFILTRATION TRENCH, INF-2
DMA 3	INFILTRATION TRENCH, INF-3
DMA 4	INFILTRATION TRENCH, INF-4

*Note: More than one drainage management area can drain to a single LID BMP, however, one drainage management area may not drain to more than one BMP.*

## Section D: Implement LID BMPs

### D.1 Infiltration Applicability

Is there an approved downstream ‘Highest and Best Use’ for stormwater runoff (see discussion in Chapter 2.4.4 of the WQMP Guidance Document for further details)?  Y  N

If yes has been checked, Infiltration BMPs shall not be used for the site. If no, continue working through this section to implement your LID BMPs. It is recommended that you contact your Co-Permittee to verify whether or not your project discharges to an approved downstream ‘Highest and Best Use’ feature.

#### Geotechnical Report

A Geotechnical Report or Phase I Environmental Site Assessment may be required by the Copermitee to confirm present and past site characteristics that may affect the use of Infiltration BMPs. In addition, the Co-Permittee, at their discretion, may not require a geotechnical report for small projects as described in Chapter 2 of the WQMP Guidance Document. If a geotechnical report has been prepared, include it in Appendix 3. In addition, if a Phase I Environmental Site Assessment has been prepared, include it in Appendix 4.

Is this project classified as a small project consistent with the requirements of Chapter 2 of the WQMP Guidance Document?  Y  N

#### Infiltration Feasibility

Table D.1 below is meant to provide a simple means of assessing which DMAs on your site support Infiltration BMPs and is discussed in the WQMP Guidance Document in Chapter 2.4.5. Check the appropriate box for each question and then list affected DMAs as applicable. If additional space is needed, add a row below the corresponding answer.

Table D.1 Infiltration Feasibility

Does the project site...	YES	NO
...have any DMAs with a seasonal high groundwater mark shallower than 10 feet? If Yes, list affected DMAs:		X
...have any DMAs located within 100 feet of a water supply well? If Yes, list affected DMAs:		X
...have any areas identified by the geotechnical report as posing a public safety risk where infiltration of stormwater could have a negative impact? If Yes, list affected DMAs:		X
...have measured in-situ infiltration rates of less than 1.6 inches / hour? If Yes, list affected DMAs:		X
...have significant cut and/or fill conditions that would preclude in-situ testing of infiltration rates at the final infiltration surface? If Yes, list affected DMAs:		X
...geotechnical report identify other site-specific factors that would preclude effective and safe infiltration? Describe here:		X

If you answered “Yes” to any of the questions above for any DMA, Infiltration BMPs should not be used for those DMAs and you should proceed to the assessment for Harvest and Use below.

## D.2 Harvest and Use Assessment

Please check what applies:

- Reclaimed water will be used for the non-potable water demands for the project.
- Downstream water rights may be impacted by Harvest and Use as approved by the Regional Board (verify with the Copermittee).
- The Design Capture Volume will be addressed using Infiltration Only BMPs. In such a case, Harvest and Use BMPs are still encouraged, but it would not be required if the Design Capture Volume will be infiltrated or evapotranspired.

If any of the above boxes have been checked, Harvest and Use BMPs need not be assessed for the site. If neither of the above criteria applies, follow the steps below to assess the feasibility of irrigation use, toilet use and other non-potable uses (e.g., industrial use).

### Irrigation Use Feasibility

Complete the following steps to determine the feasibility of harvesting stormwater runoff for Irrigation Use BMPs on your site:

Step 1: Identify the total area of irrigated landscape on the site, and the type of landscaping used.

*Total Area of Irrigated Landscape: N/A*

*Type of Landscaping (Conservation Design or Active Turf): N/A*

Step 2: Identify the planned total of all impervious areas on the proposed project from which runoff might be feasibly captured and stored for irrigation use. Depending on the configuration of buildings and other impervious areas on the site, you may consider the site as a whole, or parts of the site, to evaluate reasonable scenarios for capturing and storing runoff and directing the stored runoff to the potential use(s) identified in Step 1 above.

*Total Area of Impervious Surfaces: N/A*

Step 3: Cross reference the Design Storm depth for the project site (see Exhibit A of the WQMP Guidance Document) with the left column of Table 2-3 in Chapter 2 to determine the minimum area of Effective Irrigated Area per Tributary Impervious Area (EIATIA).

*Enter your EIATIA factor: N/A*

Step 4: Multiply the unit value obtained from Step 3 by the total of impervious areas from Step 2 to develop the minimum irrigated area that would be required.

*Minimum required irrigated area: N/A*

Step 5: Determine if harvesting stormwater runoff for irrigation use is feasible for the project by comparing the total area of irrigated landscape (Step 1) to the minimum required irrigated area (Step 4).

Minimum required irrigated area (Step 4)	Available Irrigated Landscape (Step 1)
N/A	N/A

## Toilet Use Feasibility

Complete the following steps to determine the feasibility of harvesting stormwater runoff for toilet flushing uses on your site:

Step 1: Identify the projected total number of daily toilet users during the wet season, and account for any periodic shut downs or other lapses in occupancy:

*Projected Number of Daily Toilet Users: N/A*

*Project Type: Commercial*

Step 2: Identify the planned total of all impervious areas on the proposed project from which runoff might be feasibly captured and stored for toilet use. Depending on the configuration of buildings and other impervious areas on the site, you may consider the site as a whole, or parts of the site, to evaluate reasonable scenarios for capturing and storing runoff and directing the stored runoff to the potential use(s) identified in Step 1 above.

*Total Area of Impervious Surfaces: N/A*

Step 3: Enter the Design Storm depth for the project site (see Exhibit A) into the left column of Table 2-1 in Chapter 2 to determine the minimum number of toilet users per tributary impervious acre (TUTIA).

*Enter your TUTIA factor: N/A*

Step 4: Multiply the unit value obtained from Step 3 by the total of impervious areas from Step 2 to develop the minimum number of toilet users that would be required.

*Minimum number of toilet users: N/A*

Step 5: Determine if harvesting stormwater runoff for toilet flushing use is feasible for the project by comparing the Number of Daily Toilet Users (Step 1) to the minimum required number of toilet users (Step 4).

<u>Minimum required Toilet Users (Step 4)</u>	<u>Projected number of toilet users (Step 1)</u>
N/A	N/A

## Other Non-Potable Use Feasibility

Are there other non-potable uses for stormwater runoff on the site (e.g. industrial use)? See Chapter 2 of the Guidance for further information. If yes, describe below. If no, write N/A.

None.

Step 1: Identify the projected average daily non-potable demand, in gallons per day, during the wet season and accounting for any periodic shut downs or other lapses in occupancy or operation.

*Average Daily Demand: N/A*

Step 2: Identify the planned total of all impervious areas on the proposed project from which runoff might be feasibly captured and stored for the identified non-potable use. Depending on the configuration of buildings and other impervious areas on the site, you may consider the site as

a whole, or parts of the site, to evaluate reasonable scenarios for capturing and storing runoff and directing the stored runoff to the potential use(s) identified in Step 1 above.

*Total Area of Impervious Surfaces: N/A*

Step 3: Enter the Design Storm depth for the project site (see Exhibit A) into the left column of Table 2-3 in Chapter 2 to determine the minimum demand for non-potable uses per tributary impervious acre.

*Enter the factor from Table 2-3: N/A*

Step 4: Multiply the unit value obtained from Step 4 by the total of impervious areas from Step 3 to develop the minimum number of gallons per day of non-potable use that would be required.

*Minimum required use: N/A*

Step 5: Determine if harvesting stormwater runoff for other non-potable use is feasible for the project by comparing the Number of Daily Toilet Users (Step 1) to the minimum required number of toilet users (Step 4).

<b>Minimum required non-potable use (Step 4)</b>	<b>Projected average daily use (Step 1)</b>
N/A	N/A

If Irrigation, Toilet and Other Use feasibility anticipated demands are less than the applicable minimum values, Harvest and Use BMPs are not required and you should proceed to utilize LID Bioretention and Biotreatment, unless a site-specific analysis has been completed that demonstrates technical infeasibility as noted in D.3 below.

### **D.3 Bioretention and Biotreatment Assessment**

Other LID Bioretention and Biotreatment BMPs as described in Chapter 2.4.7 of the WQMP Guidance Document are feasible on nearly all development sites with sufficient advance planning.

*Select one of the following:*

- LID Bioretention/Biotreatment BMPs will be used for some or all DMAs of the project as noted below in Section D.4 (note the requirements of Section 3.4.2 in the WQMP Guidance Document).
- A site-specific analysis demonstrating the technical infeasibility of all LID BMPs has been performed and is included in Appendix 5. If you plan to submit an analysis demonstrating the technical infeasibility of LID BMPs, request a pre-submittal meeting with the Copermittee to discuss this option. Proceed to Section E to document your alternative compliance measures.

## D.4 Feasibility Assessment Summaries

From the Infiltration, Harvest and Use, Bioretention and Biotreatment Sections above, complete Table D.2 below to summarize which LID BMPs are technically feasible, and which are not, based upon the established hierarchy.

Table D.2 LID Prioritization Summary Matrix

DMA Name/ID	LID BMP Hierarchy				No LID (Alternative Compliance)
	1. Infiltration	2. Harvest and use	3. Bioretention	4. Biotreatment	
DMA 1	<input checked="" type="checkbox"/>	<input type="checkbox"/>	<input type="checkbox"/>	<input type="checkbox"/>	<input type="checkbox"/>
DMA 2	<input checked="" type="checkbox"/>	<input type="checkbox"/>	<input type="checkbox"/>	<input type="checkbox"/>	<input type="checkbox"/>
DMA 3	<input checked="" type="checkbox"/>	<input type="checkbox"/>	<input type="checkbox"/>	<input type="checkbox"/>	<input type="checkbox"/>
DMA 4	<input checked="" type="checkbox"/>	<input type="checkbox"/>	<input type="checkbox"/>	<input type="checkbox"/>	<input type="checkbox"/>
	<input type="checkbox"/>	<input type="checkbox"/>	<input type="checkbox"/>	<input type="checkbox"/>	<input type="checkbox"/>
	<input type="checkbox"/>	<input type="checkbox"/>	<input type="checkbox"/>	<input type="checkbox"/>	<input type="checkbox"/>

For those DMAs where LID BMPs are not feasible, provide a brief narrative below summarizing why they are not feasible, include your technical infeasibility criteria in Appendix 5, and proceed to Section E below to document Alternative Compliance measures for those DMAs. Recall that each proposed DMA must pass through the LID BMP hierarchy before alternative compliance measures may be considered.



## D.5 LID BMP Sizing (BMP-1)

Each LID BMP must be designed to ensure that the Design Capture Volume will be addressed by the selected BMPs. First, calculate the Design Capture Volume for each LID BMP using the  $V_{BMP}$  worksheet in Appendix F of the LID BMP Design Handbook. Second, design the LID BMP to meet the required  $V_{BMP}$  using a method approved by the Copermittee. Utilize the worksheets found in the LID BMP Design Handbook or consult with your Copermittee to assist you in correctly sizing your LID BMPs. Complete Table D.3 below to document the Design Capture Volume and the Proposed Volume for each LID BMP. Provide the completed design procedure sheets for each LID BMP in Appendix 6. You may add additional rows to the table below as needed.

Table D.3.1 DCV Calculations for LID BMPs

DMA Type/ID	DMA Area (square feet)	Post-Project Surface Type	Effective Impervious Fraction, $I_f$	DMA Runoff Factor	DMA Areas x Runoff Factor	Infiltration Trench (INF-1)		
						Design Storm Depth (in)	Design Capture Volume, $V_{BMP}$ (cubic feet)	Proposed Volume on Plans (cubic feet)
	[A]		[B]	[C]	[A] x [C]			
<b>DMA - 1</b>	135,761	MIXED SURFACE TYPES	0.748	0.54	73,530.8			
	135,761				$\Sigma = [D]$ 73,530.8	0.65	3,982.9 CF	9,761 CF

[B], [C] is obtained as described in Section 2.3.1 of the WQMP Guidance Document

[E] is obtained from Exhibit A in the WQMP Guidance Document

[G] is obtained from a design procedure sheet, such as in LID BMP Design Handbook and placed in Appendix 6

## D.5 LID BMP Sizing (BMP-2)

Each LID BMP must be designed to ensure that the Design Capture Volume will be addressed by the selected BMPs. First, calculate the Design Capture Volume for each LID BMP using the  $V_{BMP}$  worksheet in Appendix F of the LID BMP Design Handbook. Second, design the LID BMP to meet the required  $V_{BMP}$  using a method approved by the Copermittee. Utilize the worksheets found in the LID BMP Design Handbook or consult with your Copermittee to assist you in correctly sizing your LID BMPs. Complete Table D.3 below to document the Design Capture Volume and the Proposed Volume for each LID BMP. Provide the completed design procedure sheets for each LID BMP in Appendix 6. You may add additional rows to the table below as needed.

Table D.4.1 DCV Calculations for LID BMPs

DMA Type/ID	DMA Area (square feet)	Post-Project Surface Type	Effective Impervious Fraction, $I_f$	DMA Runoff Factor	DMA Areas x Runoff Factor	Infiltration Trench (INF-2)		
						Design Storm Depth (in)	Design Capture Volume, $V_{BMP}$ (cubic feet)	Proposed Volume on Plans (cubic feet)
	[A]		[B]	[C]	[A] x [C]			
<b>DMA – 2</b>	211,500	MIXED SURFACE TYPES	0.769	0.56	119,312.6			
	211,500				$\Sigma = [D]$ 119,312.6	0.65	6,462.8 CF	16,489 CF

[B], [C] is obtained as described in Section 2.3.1 of the WQMP Guidance Document

[E] is obtained from Exhibit A in the WQMP Guidance Document

[G] is obtained from a design procedure sheet, such as in LID BMP Design Handbook and placed in Appendix 6

## D.5 LID BMP Sizing (BMP-3)

Each LID BMP must be designed to ensure that the Design Capture Volume will be addressed by the selected BMPs. First, calculate the Design Capture Volume for each LID BMP using the  $V_{BMP}$  worksheet in Appendix F of the LID BMP Design Handbook. Second, design the LID BMP to meet the required  $V_{BMP}$  using a method approved by the Copermittee. Utilize the worksheets found in the LID BMP Design Handbook or consult with your Copermittee to assist you in correctly sizing your LID BMPs. Complete Table D.3 below to document the Design Capture Volume and the Proposed Volume for each LID BMP. Provide the completed design procedure sheets for each LID BMP in Appendix 6. You may add additional rows to the table below as needed.

Table D.5.1 DCV Calculations for LID BMPs

DMA Type/ID	DMA Area (square feet)	Post-Project Surface Type	Effective Impervious Fraction, $I_f$	DMA Runoff Factor	DMA Areas x Runoff Factor	Infiltration Trench (INF-3)		
						Design Storm Depth (in)	Design Capture Volume, $V_{BMP}$ (cubic feet)	Proposed Volume on Plans (cubic feet)
	[A]		[B]	[C]	[A] x [C]			
<b>DMA – 3</b>	81,584	MIXED SURFACE TYPES	0.947	0.80	65,442			
	81,584				$\Sigma = [D]$ 65,442	0.65	3,544.8 CF	6,263 CF

[B], [C] is obtained as described in Section 2.3.1 of the WQMP Guidance Document

[E] is obtained from Exhibit A in the WQMP Guidance Document

[G] is obtained from a design procedure sheet, such as in LID BMP Design Handbook and placed in Appendix 6

## D.5 LID BMP Sizing (BMP-4)

Each LID BMP must be designed to ensure that the Design Capture Volume will be addressed by the selected BMPs. First, calculate the Design Capture Volume for each LID BMP using the  $V_{BMP}$  worksheet in Appendix F of the LID BMP Design Handbook. Second, design the LID BMP to meet the required  $V_{BMP}$  using a method approved by the Copermittee. Utilize the worksheets found in the LID BMP Design Handbook or consult with your Copermittee to assist you in correctly sizing your LID BMPs. Complete Table D.3 below to document the Design Capture Volume and the Proposed Volume for each LID BMP. Provide the completed design procedure sheets for each LID BMP in Appendix 6. You may add additional rows to the table below as needed.

Table D.6.1 DCV Calculations for LID BMPs

DMA Type/ID	DMA Area (square feet)	Post-Project Surface Type	Effective Impervious Fraction, $I_f$	DMA Runoff Factor	DMA Areas x Runoff Factor	<i>Infiltration Trench (INF-4)</i>		
						Design Storm Depth (in)	Design Capture Volume, $V_{BMP}$ (cubic feet)	Proposed Volume on Plans (cubic feet)
	[A]		[B]	[C]	[A] x [C]			
<b>DMA – 4</b>	17,614	MIXED SURFACE TYPES	0.897	0.73	12,786.5			
	17,614				$\Sigma = [D]$ 12,786.5	0.65	692.6 CF	1,243 CF

[B], [C] is obtained as described in Section 2.3.1 of the WQMP Guidance Document

[E] is obtained from Exhibit A in the WQMP Guidance Document

[G] is obtained from a design procedure sheet, such as in LID BMP Design Handbook and placed in Appendix 6

\*Volume provided to accommodate required volume for 100-year storm event (31,816 cf).

**Effective Impervious Fraction, I<sub>f</sub>:**

(Impervious Fraction values per the Water Quality Management Plan Guidance Document for the Santa Ana Region of Riverside County Table 2-1, pg.22. Values selected for impervious surface I<sub>f</sub>=1 and for Ornamental landscaping I<sub>f</sub>=0.1.)

DMA-1

Total Area (A<sub>T</sub>)= 135,761 sf

Impervious Area (A<sub>Imp1</sub>) = 97,838 sf , I<sub>f</sub> = 1.0

Pervious Area (A<sub>Per1</sub>) = 37,923 sf , I<sub>f</sub> = 0.10

$$I_{f-ave1} = (97,838*1 + 37,923*0.10)/135,761$$

**I<sub>f-ave1</sub> = 0.748**

DMA-2

Total Area (A<sub>T</sub>)= 211,500 sf

Impervious Area (A<sub>Imp2</sub>) = 157,200 sf , I<sub>f</sub> = 1

Pervious Area (A<sub>Per2</sub>) = 54,300 sf , I<sub>f</sub> = 0.10

$$I_{f-ave2} = (157,200*1 + 54,300*0.10)/211,500$$

**I<sub>f-ave2</sub> = 0.769**

DMA-3 (ALESSANDRO BLVD & LASSELLE ST.)

Total Area (A<sub>T</sub>)= 81,584 sf

Impervious Area (A<sub>Imp3</sub>) = 76,663 sf , I<sub>f</sub> = 1

Pervious Area (A<sub>Per3</sub>) = 4,921 sf , I<sub>f</sub> = 0.10

$$I_{f-ave3} = (76,663*1 + 4,921*0.10)/81,584$$

**I<sub>f-ave3</sub> = 0.947**

DMA-4 (TIMO ST.)

Total Area (A<sub>T</sub>)= 17,614 sf

Impervious Area (A<sub>Imp4</sub>) = 15,594 sf , I<sub>f</sub> = 1

Pervious Area (A<sub>Per4</sub>) = 2,020 sf , I<sub>f</sub> = 0.10

$$I_{f-ave4} = (15,594*1 + 2,020*0.10)/17,614$$

**I<sub>f-ave4</sub> = 0.897**

## Section E: Alternative Compliance (LID Waiver Program)

LID BMPs are expected to be feasible on virtually all projects. Where LID BMPs have been demonstrated to be infeasible as documented in Section D, other Treatment Control BMPs must be used (subject to LID waiver approval by the Copermittee). Check one of the following Boxes:

LID Principles and LID BMPs have been incorporated into the site design to fully address all Drainage Management Areas. No alternative compliance measures are required for this project and thus this Section is not required to be completed.

- Or -

The following Drainage Management Areas are unable to be addressed using LID BMPs. A site-specific analysis demonstrating technical infeasibility of LID BMPs has been approved by the Co-Permittee and included in Appendix 5. Additionally, no downstream regional and/or sub-regional LID BMPs exist or are available for use by the project. The following alternative compliance measures on the following pages are being implemented to ensure that any pollutant loads expected to be discharged by not incorporating LID BMPs, are fully mitigated.

N/A

## E.1 Identify Pollutants of Concern

Utilizing Table A.1 from Section A above which noted your project's receiving waters and their associated EPA approved 303(d) listed impairments, cross reference this information with that of your selected Priority Development Project Category in Table E.1 below. If the identified General Pollutant Categories are the same as those listed for your receiving waters, then these will be your Pollutants of Concern and the appropriate box or boxes will be checked on the last row. The purpose of this is to document compliance and to help you appropriately plan for mitigating your Pollutants of Concern in lieu of implementing LID BMPs.

Table E.1 Potential Pollutants by Land Use Type

Priority Project Categories and/or Project Features (check those that apply)	General Pollutant Categories							
	Bacterial Indicators	Metals	Nutrients	Pesticides	Toxic Organic Compounds	Sediments	Trash & Debris	Oil & Grease
<input type="checkbox"/> Detached Residential Development	P	N	P	P	N	P	P	P
<input type="checkbox"/> Attached Residential Development	P	N	P	P	N	P	P	P <sup>(2)</sup>
<input type="checkbox"/> Commercial/Industrial Development	P <sup>(3)</sup>	P	P <sup>(1)</sup>	P <sup>(1)</sup>	P <sup>(5)</sup>	P <sup>(1)</sup>	P	P
<input type="checkbox"/> Automotive Repair Shops	N	P	N	N	P <sup>(4, 5)</sup>	N	P	P
<input type="checkbox"/> Restaurants (>5,000 ft <sup>2</sup> )	P	N	N	N	N	N	P	P
<input type="checkbox"/> Hillside Development (>5,000 ft <sup>2</sup> )	P	N	P	P	N	P	P	P
<input type="checkbox"/> Parking Lots (>5,000 ft <sup>2</sup> )	P <sup>(6)</sup>	P	P <sup>(1)</sup>	P <sup>(1)</sup>	P <sup>(4)</sup>	P <sup>(1)</sup>	P	P
<input type="checkbox"/> Retail Gasoline Outlets	N	P	N	N	P	N	P	P
<b>Project Priority Pollutant(s) of Concern</b>	<input type="checkbox"/>	<input type="checkbox"/>	<input type="checkbox"/>	<input type="checkbox"/>	<input type="checkbox"/>	<input type="checkbox"/>	<input type="checkbox"/>	<input type="checkbox"/>

P = Potential

N = Not Potential

<sup>(1)</sup> A potential Pollutant if non-native landscaping exists or is proposed onsite; otherwise not expected

<sup>(2)</sup> A potential Pollutant if the project includes uncovered parking areas; otherwise not expected

<sup>(3)</sup> A potential Pollutant is land use involving animal waste

<sup>(4)</sup> Specifically petroleum hydrocarbons

<sup>(5)</sup> Specifically solvents

<sup>(6)</sup> Bacterial indicators are routinely detected in pavement runoff

## E.2 Stormwater Credits

Projects that cannot implement LID BMPs but nevertheless implement smart growth principles are potentially eligible for Stormwater Credits. Utilize Table 3-8 within the WQMP Guidance Document to identify your Project Category and its associated Water Quality Credit. If not applicable, write N/A.

**Table E.2 Water Quality Credits**

Qualifying Project Categories	Credit Percentage <sup>2</sup>
N/A	N/A
<i>Total Credit Percentage<sup>1</sup></i>	

<sup>1</sup>Cannot Exceed 50%

<sup>2</sup>Obtain corresponding data from Table 3-8 in the WQMP Guidance Document

## E.3 Sizing Criteria

After you appropriately considered Stormwater Credits for your project, utilize Table E.3 below to appropriately size them to the DCV, or Design Flow Rate, as applicable. Please reference Chapter 3.5.2 of the WQMP Guidance Document for further information.

**Table E.3 Treatment Control BMP Sizing**

DMA Type/ID	DMA Area (square feet)	Post-Project Surface Type	Effective Impervious Fraction, I <sub>f</sub>	DMA Runoff Factor	DMA Area x Runoff Factor	Enter BMP Name / Identifier Here									
[A]	[A]		[B]	[C]	[A] x [C]										
						<table border="0" style="width: 100%; text-align: center;"> <tr> <td><i>Minimum Design Capture</i></td> <td><i>or</i></td> <td><i>Proposed Volume or Flow on Plans</i></td> </tr> <tr> <td><i>Design Storm Depth (in)</i></td> <td><i>Design Rate (feet or cfs)</i></td> <td><i>Total Storm Water Credit % Reduction</i></td> </tr> <tr> <td></td> <td></td> <td><i>(cubic feet or cfs)</i></td> </tr> </table>	<i>Minimum Design Capture</i>	<i>or</i>	<i>Proposed Volume or Flow on Plans</i>	<i>Design Storm Depth (in)</i>	<i>Design Rate (feet or cfs)</i>	<i>Total Storm Water Credit % Reduction</i>			<i>(cubic feet or cfs)</i>
<i>Minimum Design Capture</i>	<i>or</i>	<i>Proposed Volume or Flow on Plans</i>													
<i>Design Storm Depth (in)</i>	<i>Design Rate (feet or cfs)</i>	<i>Total Storm Water Credit % Reduction</i>													
		<i>(cubic feet or cfs)</i>													
$A_T = \frac{\sum[A]}{\Sigma = [D] \quad [E] \quad [F] = \frac{[D] \times [E]}{[G]} \quad [F] \times (1 - [H]) \quad [I]}$															

[B], [C] is obtained as described in Section 2.3.1 from the WQMP Guidance Document

[E] is obtained from Exhibit A in the WQMP Guidance Document

[G] is for Flow-Based Treatment Control BMPs [G] = 43,560, for Volume-Based Control Treatment BMPs, [G] = 12

[H] is from the Total Credit Percentage as Calculated from Table E.2 above

[I] as obtained from a design procedure sheet from the BMP manufacturer and should be included in Appendix 6



## E.4 Treatment Control BMP Selection

Treatment Control BMPs typically provide proprietary treatment mechanisms to treat potential pollutants in runoff, but do not sustain significant biological processes. Treatment Control BMPs must have a removal efficiency of a medium or high effectiveness as quantified below:

- **High:** equal to or greater than 80% removal efficiency
- **Medium:** between 40% and 80% removal efficiency

Such removal efficiency documentation (e.g., studies, reports, etc.) as further discussed in Chapter 3.5.2 of the WQMP Guidance Document, must be included in Appendix 6. In addition, ensure that proposed Treatment Control BMPs are properly identified on the WQMP Site Plan in Appendix 1.

**Table E.4 Treatment Control BMP Selection**

Selected Treatment Control BMP Name or ID <sup>1</sup>	Priority Pollutant(s) of Concern to Mitigate <sup>2</sup>	Removal Percentage <sup>3</sup>	Efficiency

<sup>1</sup> Treatment Control BMPs must not be constructed within Receiving Waters. In addition, a proposed Treatment Control BMP may be listed more than once if they possess more than one qualifying pollutant removal efficiency.

<sup>2</sup> Cross Reference Table E.1 above to populate this column.

<sup>3</sup> As documented in a Co-Permittee Approved Study and provided in Appendix 6.

# Section F: Hydromodification

## F.1 Hydrologic Conditions of Concern (HCOC) Analysis

Once you have determined that the LID design is adequate to address water quality requirements, you will need to assess if the proposed LID Design may still create a HCOC. Review Chapters 2 and 3 (including Figure 3-7) of the WQMP Guidance Document to determine if your project must mitigate for Hydromodification impacts. If your project meets one of the following criteria which will be indicated by the check boxes below, you do not need to address Hydromodification at this time. However, if the project does not qualify for Exemptions 1, 2 or 3, then additional measures must be added to the design to comply with HCOC criteria. This is discussed in further detail below in Section F.2.

**HCOC EXEMPTION 1:** The Priority Development Project disturbs less than one acre. The Copermitttee has the discretion to require a Project-Specific WQMP to address HCOCs on projects less than one acre on a case by case basis. The disturbed area calculation should include all disturbances associated with larger common plans of development.

Does the project qualify for this HCOC Exemption?       Y     N

If Yes, HCOC criteria do not apply.

**HCOC EXEMPTION 2:** The volume and time of concentration<sup>1</sup> of storm water runoff for the post-development condition is not significantly different from the pre-development condition for a 2-year return frequency storm (a difference of 5% or less is considered insignificant) using one of the following methods to calculate:

- Riverside County Hydrology Manual
- Technical Release 55 (TR-55): Urban Hydrology for Small Watersheds (NRCS 1986), or derivatives thereof, such as the Santa Barbara Urban Hydrograph Method
- Other methods acceptable to the Co-Permittee

Does the project qualify for this HCOC Exemption?       Y     N

If Yes, report results in Table F.1 below and provide your substantiated hydrologic analysis in Appendix 7.

**Table F.1** Hydrologic Conditions of Concern Summary

	2 year – 24 hour		
	Pre-condition	Post-condition	% Difference
<b>Time of Concentration</b>	N/A	N/A	N/A
<b>Volume (Cubic Feet)</b>	N/A	N/A	N/A

<sup>1</sup> Time of concentration is defined as the time after the beginning of the rainfall when all portions of the drainage basin are contributing to flow at the outlet.

**HCOC EXEMPTION 3:** All downstream conveyance channels to an adequate sump (for example, Prado Dam, Lake Elsinore, Canyon Lake, Santa Ana River, or other lake, reservoir or naturally erosion resistant feature) that will receive runoff from the project are engineered and regularly maintained to ensure design flow capacity; no sensitive stream habitat areas will be adversely affected; or are not identified on the Co-Permittees Hydromodification Sensitivity Maps.

Does the project qualify for this HCOC Exemption?  Y  N

If Yes, HCOC criteria do not apply and note below which adequate sump applies to this HCOC qualifier:

Downstream conveyance channels to an adequate sump, Canyon Lake. Please see Receiving Waters Map in Appendix 7 for an exhibit showing this.

## F.2 HCOC Mitigation

If none of the above HCOC Exemption Criteria are applicable, HCOC criteria is considered mitigated if they meet one of the following conditions:

- a. Additional LID BMPS are implemented onsite or offsite to mitigate potential erosion or habitat impacts as a result of HCOCs. This can be conducted by an evaluation of site-specific conditions utilizing accepted professional methodologies published by entities such as the California Stormwater Quality Association (CASQA), the Southern California Coastal Water Research Project (SCCRWP), or other Co-Permittee approved methodologies for site-specific HCOC analysis.
- b. The project is developed consistent with an approved Watershed Action Plan that addresses HCOC in Receiving Waters.
- c. Mimicking the pre-development hydrograph with the post-development hydrograph, for a 2-year return frequency storm. Generally, the hydrologic conditions of concern are not significant, if the post-development hydrograph is no more than 10% greater than pre-development hydrograph. In cases where excess volume cannot be infiltrated or captured and reused, discharge from the site must be limited to a flow rate no greater than 110% of the pre-development 2-year peak flow.

Be sure to include all pertinent documentation used in your analysis of the items a, b or c in Appendix 7.

## Section G: Source Control BMPs

Source control BMPs include permanent, structural features that may be required in your project plans — such as roofs over and berms around trash and recycling areas — and Operational BMPs, such as regular sweeping and “housekeeping”, that must be implemented by the site’s occupant or user. The MEP standard typically requires both types of BMPs. In general, Operational BMPs cannot be substituted for a feasible and effective permanent BMP. Using the Pollutant Sources/Source Control Checklist in Appendix 8, review the following procedure to specify Source Control BMPs for your site:

1. **Identify Pollutant Sources:** Review Column 1 in the Pollutant Sources/Source Control Checklist. Check off the potential sources of Pollutants that apply to your site.
2. **Note Locations on Project-Specific WQMP Exhibit:** Note the corresponding requirements listed in Column 2 of the Pollutant Sources/Source Control Checklist. Show the location of each Pollutant source and each permanent Source Control BMP in your Project-Specific WQMP Exhibit located in Appendix 1.
3. **Prepare a Table and Narrative:** Check off the corresponding requirements listed in Column 3 in the Pollutant Sources/Source Control Checklist. In the left column of Table G.1 below, list each potential source of runoff Pollutants on your site (from those that you checked in the Pollutant Sources/Source Control Checklist). In the middle column, list the corresponding permanent, Structural Source Control BMPs (from Columns 2 and 3 of the Pollutant Sources/Source Control Checklist) used to prevent Pollutants from entering runoff. **Add additional narrative** in this column that explains any special features, materials or methods of construction that will be used to implement these permanent, Structural Source Control BMPs.
4. **Identify Operational Source Control BMPs:** To complete your table, refer once again to the Pollutant Sources/Source Control Checklist. List in the right column of your table the Operational BMPs that should be implemented as long as the anticipated activities continue at the site. Copermittee stormwater ordinances require that applicable Source Control BMPs be implemented; the same BMPs may also be required as a condition of a use permit or other revocable Discretionary Approval for use of the site.

**Table G.1 Permanent and Operational Source Control Measures**

Potential Sources of Runoff pollutants	Permanent Structural Source Control BMPs	Operational Source Control BMPs
On-Site storm drains inlets	Locations of inlets	Maintain and periodically repaint or replace inlet markings. Provide stormwater pollution prevention information to new site owners, lessees, or operators. See applicable operational BMPs in Fact Sheet SC-44, “Drainage System Maintenance,” in the CASQA Stormwater Quality Handbooks at <a href="http://www.cabmphandbooks.com">www.cabmphandbooks.com</a> Include the following in lease agreements: “Tenant shall not

		allow anyone to discharge anything to storm drains or to store or deposit materials so as to create a potential discharge to storm drains.”
Landscape/ Outdoor Pest	<p>Show locations of native trees or areas of shrubs and ground cover to be undisturbed and retained.</p> <p>Show self-retaining landscape areas, if any.</p> <p>Show stormwater treatment and hydrograph modification management BMPs. (See instructions in Chapter 3, Step 5 and guidance in Chapter 5.)</p>	<p>Preserve existing native trees, shrubs, and ground cover to the maximum extent possible. Design landscaping to minimize irrigation and runoff, to promote surface infiltration where appropriate, and to minimize the use of fertilizers and pesticides that can contribute to stormwater pollution.</p> <p>Where landscaped areas are used to retain or detain stormwater, specify plants that are tolerant of saturated soil conditions.</p> <p>Consider using pest-resistant plants, especially adjacent to hardscape.</p> <p>To insure successful establishment, select plants appropriate to site soils, slopes, climate, sun, wind, rain, land use, air movement, ecological consistency, and plant interactions.</p>
Fuel Dispensing Areas	<p>Fueling areas shall have impermeable floors (i.e., Portland cement concrete or equivalent smooth impervious surface) that are: a) graded at the minimum slope necessary to prevent ponding; and b) separated from the rest of the site by a grade break that prevents run-on of stormwater to the maximum extent practicable.</p> <p>Fueling areas shall be covered by a canopy that extends a minimum of ten feet in each direction from each pump.</p> <p>[Alternative: The fueling area must be covered and the cover’s minimum dimensions must be equal to or greater than the area within the grade break or fuel dispensing area 1.] The canopy [or cover] shall not drain onto the fueling area.</p>	<p>The property owner shall dry sweep the fueling area routinely. See the Fact Sheet SD-30 , “Fueling Areas” in the CASQA Stormwater Quality Handbooks at <a href="http://www.cabmphandbooks.com">www.cabmphandbooks.com</a></p>

<p>Miscellaneous Drain or Wash Water or Other Sources</p> <p>-Roofing, gutters, and trim.</p>		<p>Avoid roofing, gutters, and trim made of copper or other unprotected metals that may leach into runoff.</p>
<p>Plazas, sidewalks, and parking lots.</p>		<p>Sweep plazas, sidewalks, and parking lots regularly to prevent accumulation of litter and debris. Collect debris from pressure washing to prevent entry into the storm drain system. Collect wash water containing any cleaning agent or degreaser and discharge to the sanitary sewer not to a storm drain.</p>
<p>Vehicle and Equipment Cleaning</p>	<p>Show on drawings as appropriate:</p> <p>(1) Commercial/industrial facilities having vehicle/equipment cleaning needs shall either provide a covered, bermed area for washing activities or discourage vehicle/equipment washing by removing hose bibs and installing signs prohibiting such uses.</p> <p>(2) Multi-dwelling complexes shall have a paved, bermed, and covered car wash area (unless car washing is prohibited on-site and hoses are provided with an automatic shutoff to discourage such use).</p> <p>(3) Washing areas for cars, vehicles, and equipment shall be paved, designed to prevent run-on to or runoff from the area, and plumbed to drain to the sanitary sewer.</p> <p>(4) Commercial car wash facilities shall be designed such that no runoff from the facility is discharged to the storm drain system. Wastewater from the facility shall discharge to the sanitary sewer, or a wastewater reclamation system.</p>	<p>Describe operational measures to implement the following (if applicable):</p> <p>Washwater from vehicle and equipment washing operations shall not be discharged to the storm drain system. Refer to “Outdoor Cleaning Activities and Professional Mobile Service Providers” for many of the Potential Sources of Runoff Pollutants categories below. Brochure can be found at <a href="http://rcflood.org/stormwater/">http://rcflood.org/stormwater/</a> Car dealerships and similar may rinse cars with water only.</p>
<p>Food Service</p>	<p>For restaurants, grocery stores, and other food service operations, show location (indoors or in a covered area outdoors) of a floor sink or other area for cleaning floor mats, containers, and equipment. On the drawing, show a note that this drain will be connected to a grease interceptor before discharging to the sanitary sewer.</p>	<p>See the brochure, “The Food Service Industry Best Management Practices for: Restaurants, Grocery Stores, Delicatessens and Bakeries” at <a href="http://rcflood.org/stormwater/">http://rcflood.org/stormwater/</a> Provide this brochure to new site owners, lessees, and operators.</p>
<p>Refuse Area</p>	<p>Show where site refuse and recycled materials will be</p>	<p>State how the following will be implemented:</p>

	<p>handled and stored for pickup. See local municipal requirements for sizes and other details of refuse areas. If dumpsters or other receptacles are outdoors, show how the designated area will be covered, graded, and paved to prevent run-on and show locations of berms to prevent runoff from the area. Any drains from dumpsters, compactors, and tallow bin areas shall be connected to a grease removal device before discharge to sanitary sewer.</p>	<p>Provide adequate number of receptacles. Inspect receptacles regularly; repair or replace leaky receptacles. Keep receptacles covered. Prohibit/ prevent dumping of liquid or hazardous wastes. Post "no hazardous materials" signs. Inspect and pick up litter daily and clean up spills immediately. Keep spill control materials available onsite. See Fact Sheet SC-34, "Waste Handling and Disposal" in the CASQA Stormwater Quality Handbooks at <a href="http://www.cabmphandbooks.com">www.cabmphandbooks.com</a></p>
--	--	---

## Section H: Construction Plan Checklist

Populate Table H.1 below to assist the plan checker in an expeditious review of your project. The first two columns will contain information that was prepared in previous steps, while the last column will be populated with the corresponding plan sheets. This table is to be completed with the submittal of your final Project-Specific WQMP.

**Table H.1 Construction Plan Cross-reference**

BMP No. or ID	BMP Identifier and Description	Corresponding Plan Sheet(s)
DMA-1, INF-1	Infiltration Trench	P-WQMP, Sheet C02 Grading Plan, Sheet C01
DMA-2, INF-2	Infiltration Trench	P-WQMP, Sheet C02 Grading Plan, Sheet C01
DMA-3, INF-3	Infiltration Trench	P-WQMP, Sheet C02 Grading Plan, Sheet C01
DMA-4, INF-4	Infiltration Trench	P-WQMP, Sheet C02 Grading Plan, Sheet C01

Note that the updated table — or Construction Plan WQMP Checklist — is **only a reference tool** to facilitate an easy comparison of the construction plans to your Project-Specific WQMP. Co-Permittee staff can advise you regarding the process required to propose changes to the approved Project-Specific WQMP.



## Section I: Operation, Maintenance and Funding

The Copermittee will periodically verify that Stormwater BMPs on your site are maintained and continue to operate as designed. To make this possible, your Copermittee will require that you include in Appendix 9 of this Project-Specific WQMP:

1. A means to finance and implement facility maintenance in perpetuity, including replacement cost.
2. Acceptance of responsibility for maintenance from the time the BMPs are constructed until responsibility for operation and maintenance is legally transferred. A warranty covering a period following construction may also be required.
3. An outline of general maintenance requirements for the Stormwater BMPs you have selected.
4. Figures delineating and designating pervious and impervious areas, location, and type of Stormwater BMP, and tables of pervious and impervious areas served by each facility. Geo-locating the BMPs using a coordinate system of latitude and longitude is recommended to help facilitate a future statewide database system.
5. A separate list and location of self-retaining areas or areas addressed by LID Principles that do not require specialized O&M or inspections but will require typical landscape maintenance as noted in Chapter 5, pages 85-86, in the WQMP Guidance. Include a brief description of typical landscape maintenance for these areas.

Your local Co-Permittee will also require that you prepare and submit a detailed Stormwater BMP Operation and Maintenance Plan that sets forth a maintenance schedule for each of the Stormwater BMPs built on your site. An agreement assigning responsibility for maintenance and providing for inspections and certification may also be required.

Details of these requirements and instructions for preparing a Stormwater BMP Operation and Maintenance Plan are in Chapter 5 of the WQMP Guidance Document.

**Maintenance Mechanism:** Refer to Appendix 9 for BMP Operation and Maintenance Plan Requirements.

Responsible Party: Danny Singh  
3017 E. Edinger Ave.  
Tustin, CA 92780  
(949) 630-5345  
dannysingh9@gmail.com

Will the proposed BMPs be maintained by a Home Owners' Association (HOA) or Property Owners Association (POA)?

Y       N

Include your Operation and Maintenance Plan and Maintenance Mechanism in Appendix 9. Additionally, include all pertinent forms of educational materials for those personnel that will be maintaining the proposed BMPs within this Project-Specific WQMP in Appendix 10.

# Appendix 1: Maps and Site Plans

*Location Map, WQMP Site Plan and Receiving Waters Map*

# Site Location Map

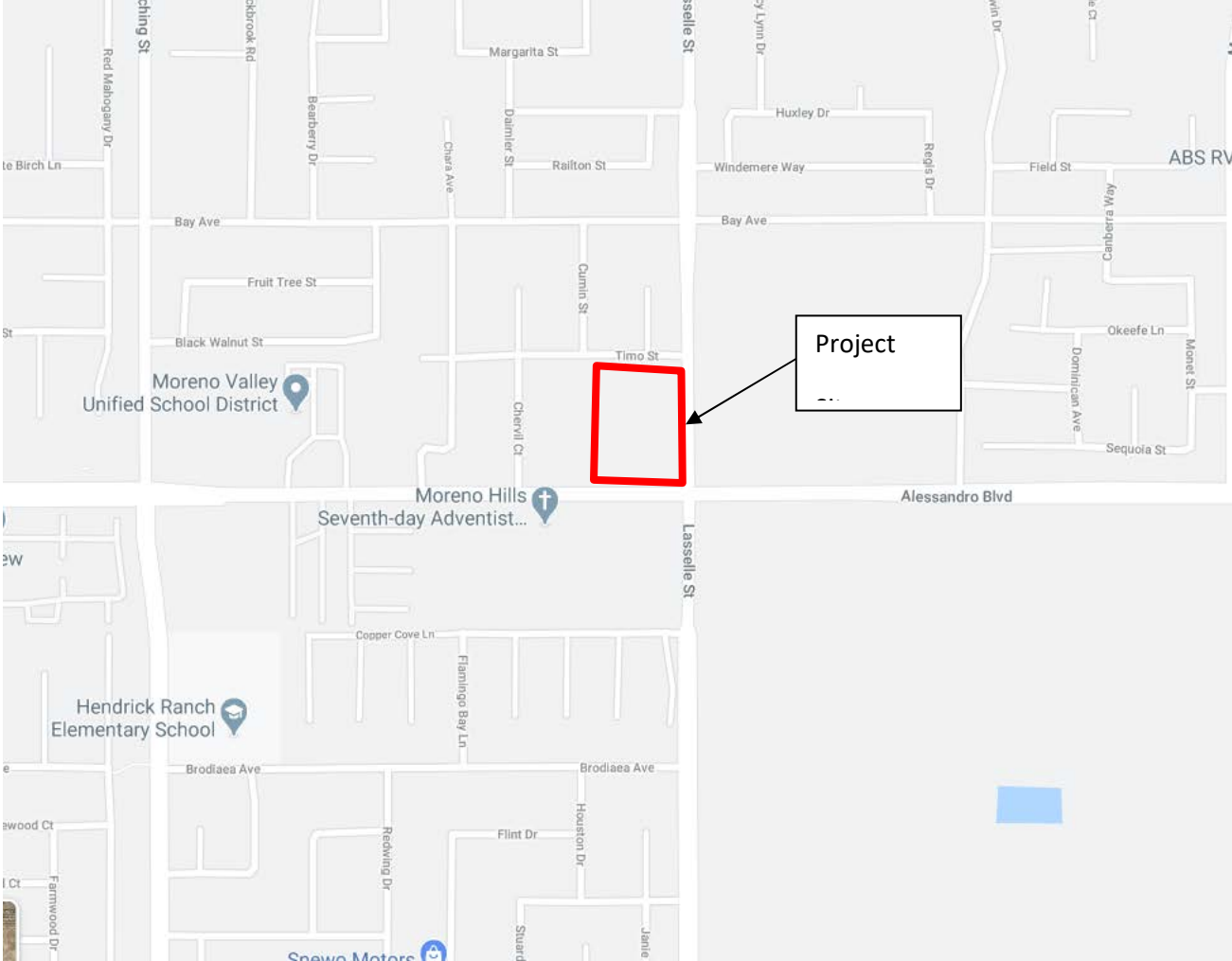



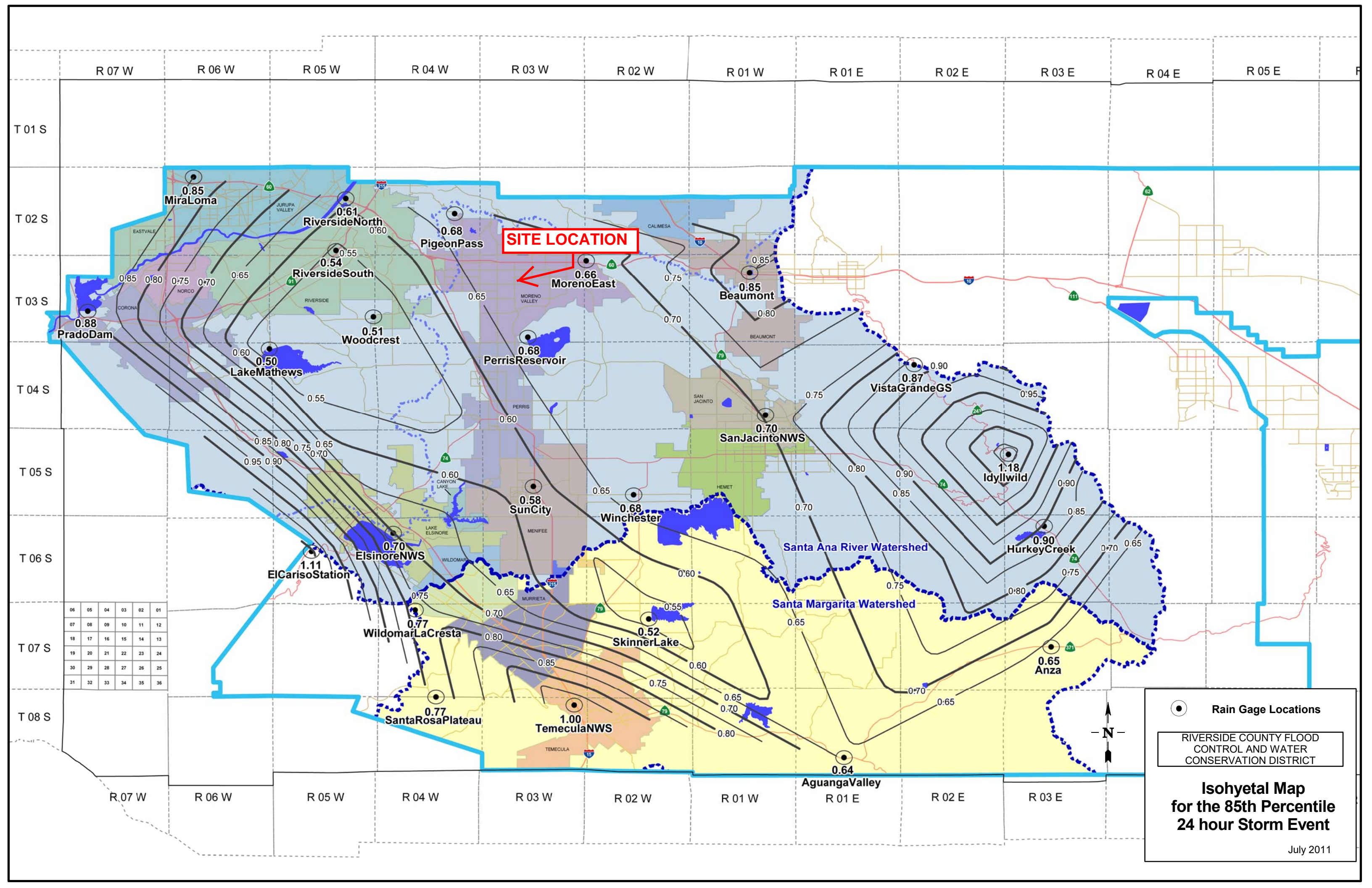

**SITE LOCATION**

06	05	04	03	02	01
07	08	09	10	11	12
18	17	16	15	14	13
19	20	21	22	23	24
30	29	28	27	26	25
31	32	33	34	35	36

● Rain Gage Locations  
 RIVERSIDE COUNTY FLOOD CONTROL AND WATER CONSERVATION DISTRICT  
**Isohyetal Map for the 85th Percentile 24 hour Storm Event**  
 July 2011

# Appendix 2: Construction Plans

*Grading and Drainage Plans*







CHERVIL CT

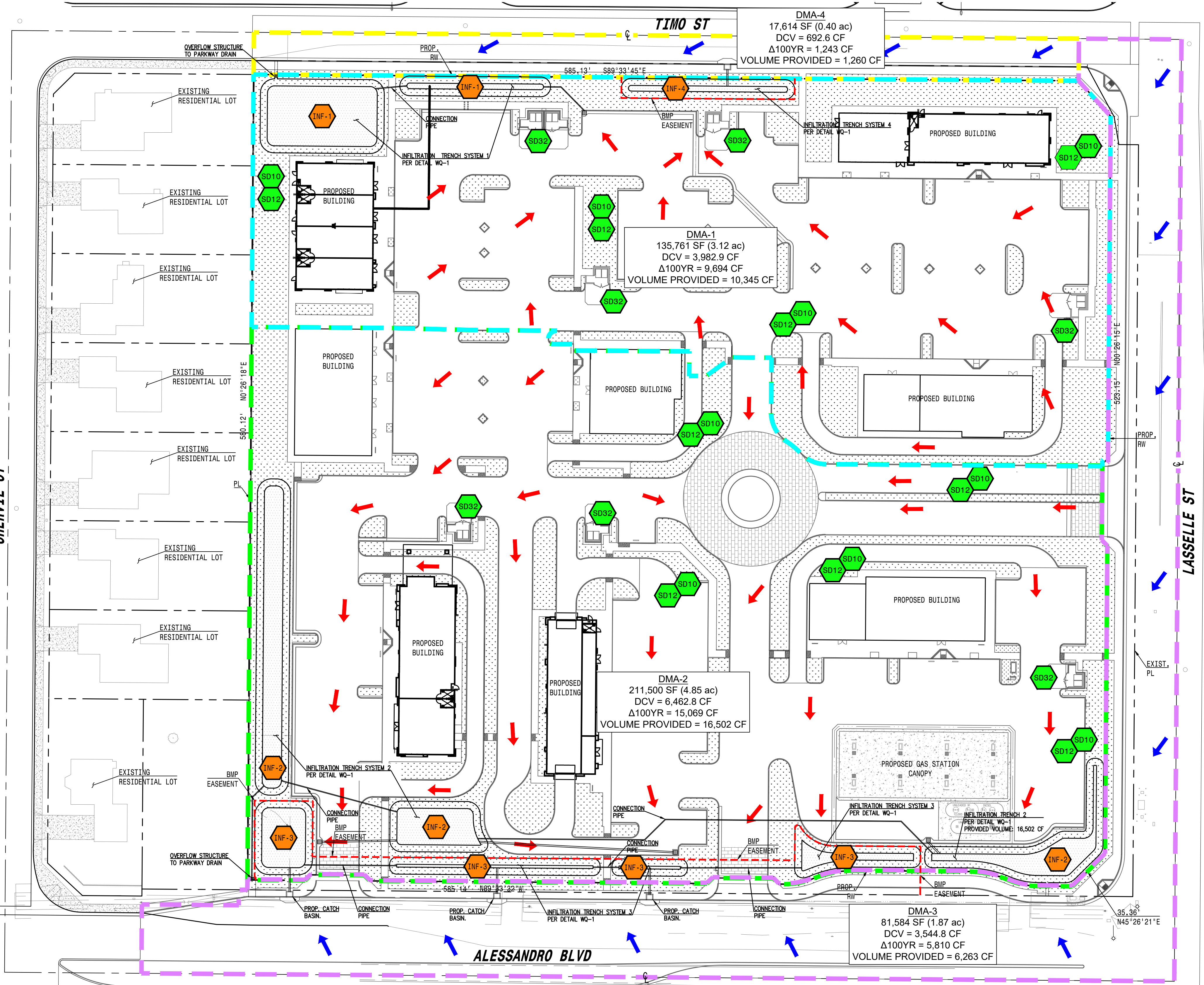

**SOURCE CONTROL BMP'S:**

- SD10 - SITE DESIGN & LANDSCAPE PLANNING
- SD12 - EFFICIENT IRRIGATION
- SD21 - ALTERNATIVE BUILDING MATERIALS
- SD32 - TRASH STORAGE AREAS

**NON STRUCTURAL CONTROL BMP'S:**

- N4 - EDUCATION FOR PROPERTY OWNERS, TENANTS AND OCCUPANTS (ENTIRE SITE)

**TREATMENT CONTROL BMP'S:**

- INF - INFILTRATION TRENCH

**LEGEND:**

- LANDSCAPE AREA
- INFILTRATION TRENCH AREA
- AC PAVEMENT
- PCC PAVEMENT
- GRIND & OVERLAY
- CONCRETE PAVERS
- LINE OF SIGHT AREA
- BMP EASEMENT
- OFFSITE DRAINAGE
- PROPOSED FLOW DIRECTION
- DMA BOUNDARY 1
- DMA BOUNDARY 2
- DMA BOUNDARY 3
- DMA BOUNDARY 4
- DMA INFORMATION

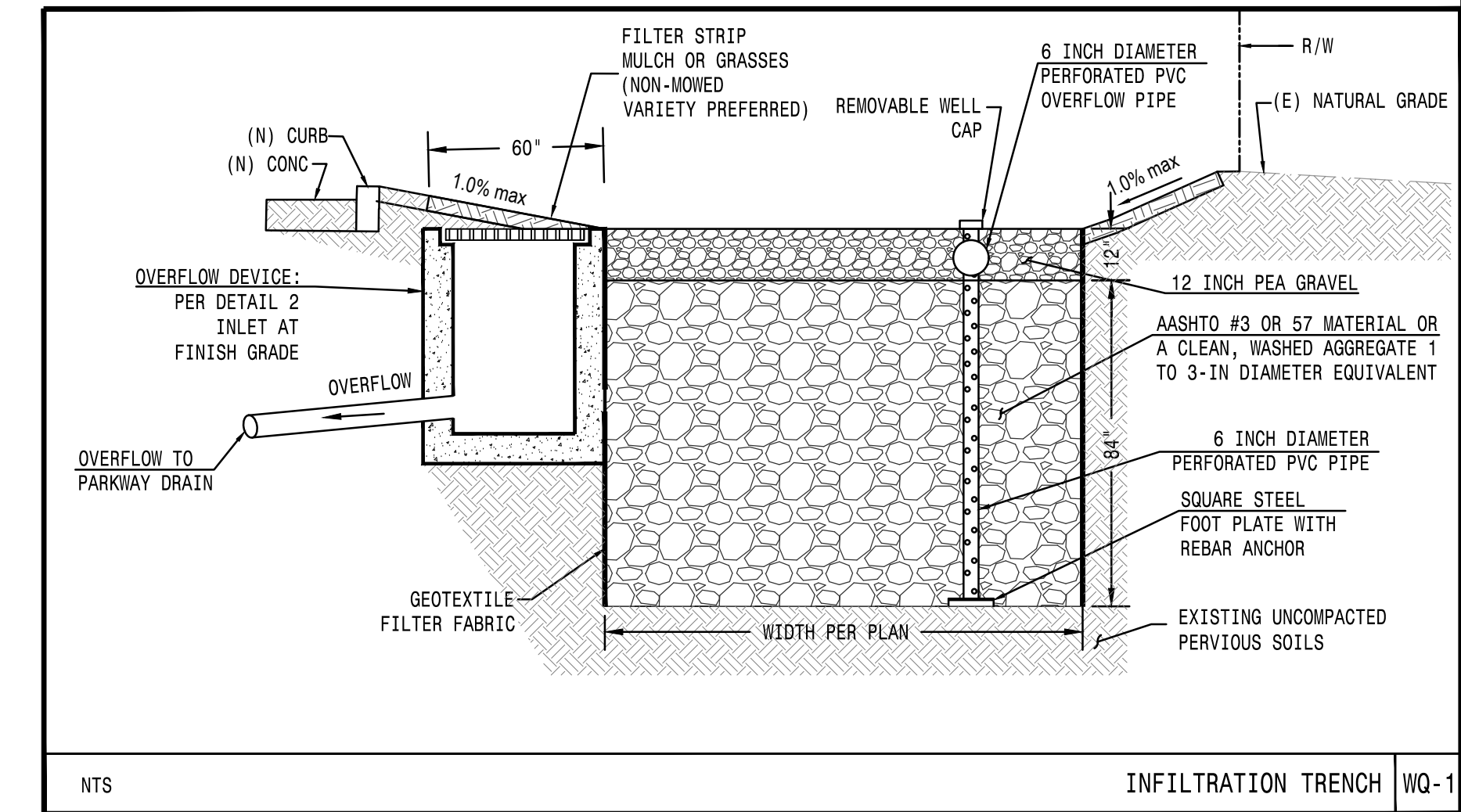

\*NOTE:  
ALL OFF-SITE INFILTRATION TRENCHES (INF-3 & INF-4) ARE TO BE DEDICATED AS BMP EASEMENTS.

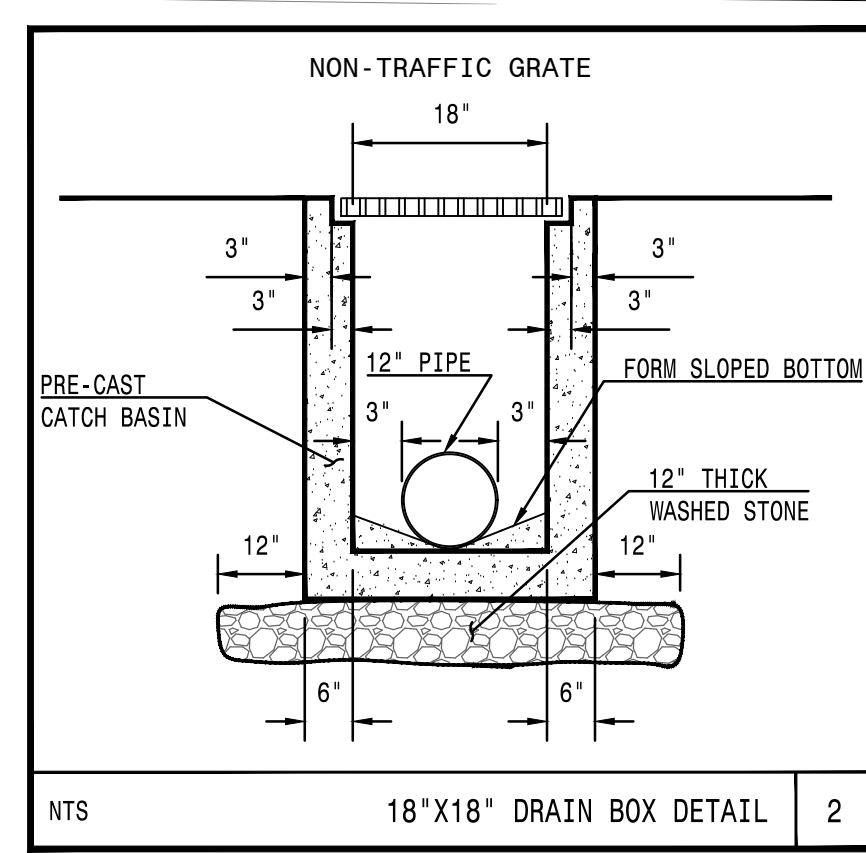

**PERVIOUS AND IMPERVIOUS AREAS**

DMA	PERVIOUS AREA	IMPERVIOUS AREA	TOTAL
1	37,923 SF (0.87 AC)	97,838 SF (2.25 AC)	135,761 SF (3.12 AC)
2	54,300 SF (1.24 AC)	157,200 SF (3.61 AC)	211,500 SF (4.85 AC)
3	4,921 SF (0.11 AC)	76,663 SF (1.76 AC)	81,584 SF (1.87 AC)
4	2,020 SF (0.05 AC)	15,594 SF (0.35 AC)	17,614 SF (0.40 AC)
TOTAL	99,165 SF (2.28 AC)	347,294 SF (7.97 AC)	446,459 SF (10.25 AC)

\*NOTE:  
ADDITIONAL CAPACITY PROVIDED TO DETERMINE THE DIFFERENCE BETWEEN THE PRE AND POST-DEVELOPMENT, 100-YR 24-HR STORM EVENTS. (31,816 CUBIC FEET)  
TOTAL VOLUME PROVIDED BY INFILTRATION TRENCHES IS 32,513 CUBIC FEET, MEETING THE REQUIRED AMOUNT.

**RUNOFF VOLUME: 100YR-24HR STORM EVENT**

DMA	PRE-DEVELOPMENT	POST-DEVELOPMENT	DIFFERENCE
1	30,876 CF	40,570 CF	9,694 CF
2	48,102 CF	63,171 CF	15,069 CF
3	18,555 CF	24,365 CF	5,810 CF
4	4,006 CF	5,249 CF	1,243 CF
TOTAL	30,876 CF	133,354 CF	31,816 CF

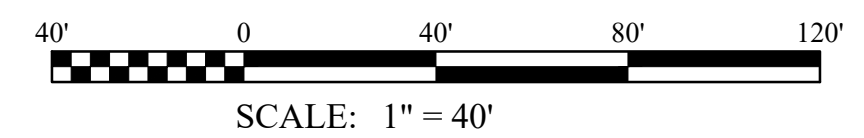

**EMPIRE DESIGN GROUP, INC.**

24861 Washington Ave.  
Murrieta, Calif. 92562  
Tel 951-696-1490 Fax 951-696-1443

**NORTHWEST MORENO PROPERTIES LLC**

**COMMERCIAL RETAIL**  
APN: 479-631-010  
**NWC ALESSANDRO BLVD. & LASSELLE ST.**  
MORENO VALLEY, CA 92553

ENGINEER OF RECORD:  
TRYFON TRYFONOPOULOS, PE  
914 E KATELLA AVE.  
ANAHEIM, CA 92805  
(714)385-1835



Date: 8/12/2022  
Project Number: 2001078

NO.	DATE	REVISION DESCRIPTION

DESIGNED BY: TT  
CHECKED BY: TT  
DRAWN BY: AA/JT/NA/DD  
DRAWING TITLE:

P-WQMP PLAN

SHEET NO:

**C03**







# Appendix 3: Soils Information

*Geotechnical Study and Other Infiltration Testing Data*

January 8, 2021

Project No. 203131-10A

Mr. Alex Hann  
**EMPIRE DESIGN GROUP, INC.**  
24861 Washington Avenue  
Murrieta, CA 92562

Subject: **Revised Updated Preliminary Geotechnical Investigation Report, Proposed Commercial Development, PEN21-0273, Assessor's Parcel Number 479-631-010, Located at the Northwest Corner of Alessandro Boulevard and Lasselle Street, City of Moreno Valley, Riverside County, California**

Earth Strata Geotechnical Services is pleased to present our revised update to the geotechnical investigation report for the proposed commercial development, Assessor's Parcel Number 479-631-010, located at the northwest corner of Alessandro Boulevard and Lasselle Street in the City of Moreno Valley, Riverside County, California. This work was performed in accordance with the scope of work described in our proposal, dated March 27, 2020. The purpose of this study is to update and re-evaluate the nature, distribution, engineering properties, and geologic strata underlying the site with respect to geotechnical investigation report prepared by Geoboden Inc.

Earth Strata Geotechnical Services appreciates the opportunity to offer our consultation and advice on this project. In the event that you have any questions, please do not hesitate to contact the undersigned at your earliest convenience.

Respectfully submitted,

EARTH STRATA GEOTECHNICAL SERVICES

  
Stephen M. Poole, PE, GE  
Principal Engineer

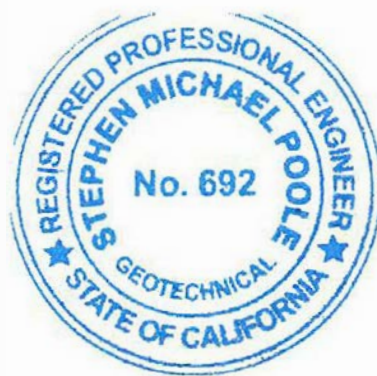

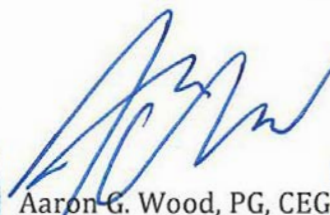
  
Aaron G. Wood, PG, CEG  
Principal Geologist

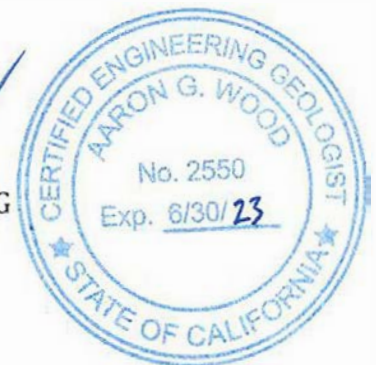

SMP/jmr/hr

Distribution: (2) Addressee

## TABLE OF CONTENTS

<u>Section</u>	<u>Page</u>
INTRODUCTION .....	1
SITE DESCRIPTION .....	1
PROPOSED DEVELOPMENT AND GRADING.....	1
FIELD EXPLORATION AND LABORATORY TESTING.....	3
Field Exploration.....	3
Laboratory Testing.....	3
FINDINGS.....	3
Regional Geology.....	3
Local Geology .....	4
Faulting.....	6
Landslides.....	6
CONCLUSIONS AND RECOMMENDATIONS.....	6
General .....	6
Earthwork.....	7
Earthwork and Grading .....	7
Clearing and Grubbing .....	7
Excavation Characteristics.....	7
Groundwater.....	7
Ground Preparation for Fill Areas.....	7
Wet Removals.....	8
Oversize Rock .....	8
Compacted Fill Placement.....	8
Import Earth Materials .....	8
Fill Slopes.....	8
Cut Slopes.....	9
Stabilization Fills.....	9
Fill Over Cut Slopes.....	9
Temporary Backcuts.....	9
Cut/Fill Transitions .....	9
Cut Areas.....	10
Shrinkage, Bulking and Subsidence .....	10
Geotechnical Observations .....	10
Post Grading Considerations .....	10
Slope Landscaping and Maintenance .....	10
Site Drainage .....	11
Utility Trenches.....	11
SEISMIC DESIGN CONSIDERATIONS.....	11
Ground Motions.....	11
Secondary Seismic Hazards .....	12
Liquefaction and Lateral Spreading.....	13
TENTATIVE FOUNDATION DESIGN RECOMMENDATIONS.....	13
General .....	13
Allowable Bearing Values.....	13
Settlement.....	13

<b>Lateral Resistance</b> .....	14
<b>Structural Setbacks and Building Clearance</b> .....	14
<b>Foundation Observations</b> .....	15
<b>Expansive Soil Considerations</b> .....	16
<b>Very Low Expansion Potential (Expansion Index of 20 or Less)</b> .....	16
<b>Footings</b> .....	16
<b>Building Floor Slabs</b> .....	16
<b>Corrosivity</b> .....	17
<b>RETAINING WALLS</b> .....	18
<b>Active and At-Rest Earth Pressures</b> .....	18
<b>Subdrain System</b> .....	18
<b>Temporary Excavations</b> .....	19
<b>Retaining Wall Backfill</b> .....	19
<b>CONCRETE FLATWORK</b> .....	19
<b>Thickness and Joint Spacing</b> .....	19
<b>Subgrade Preparation</b> .....	19
<b>PRELIMINARY ASPHALTIC CONCRETE PAVEMENT DESIGN</b> .....	20
<b>GRADING PLAN REVIEW AND CONSTRUCTION SERVICES</b> .....	20
<b>REPORT LIMITATIONS</b> .....	21

Attachments:

- Figure 1 – Vicinity Map (Page 2)
- Figure 2 – Regional Geologic Map (Page 5)
- APPENDIX A – References (Rear of Text)
- APPENDIX B – Exploratory Logs (Rear of Text)
- APPENDIX C – Laboratory Procedures and Test Results (Rear of Text)
- APPENDIX D – Seismicity (Rear of Text)
- APPENDIX E – General Earthwork and Grading Specifications (Rear of Text)
- Plate 1 – Geotechnical Map (Rear of Text)



## **INTRODUCTION**

Earth Strata Geotechnical Services is pleased to present our updated preliminary geotechnical investigation report for the proposed development. The purpose of this study was to evaluate the nature, distribution, engineering properties, and geologic strata underlying the site with respect to the proposed development, and then provide preliminary grading and foundation design recommendations based on the plans you provided. The general location of the subject property is indicated on the Vicinity Map, Figure 1. The plans you provided were used as the base map to show geologic conditions within the subject site, see Geotechnical Map, Plate 1.

## **SITE DESCRIPTION**

The subject property is located at the northwest corner of Alessandro Boulevard and Lasselle Street in the City of Moreno Valley, Riverside County, California. The approximate location of the site is shown on the Vicinity Map, Figure 1.

The subject property is comprised of approximately 8.9 acres of undeveloped land. The site has not been graded. Topographic relief at the subject property is relatively low with the terrain being generally flat. Elevations at the site range from approximately 1581 to 1597 feet above mean sea level (msl), for a difference of about 16± feet across the entire site. Drainage within the subject property generally flows to the south.

The site is currently bordered by residential development to the west, Alessandro Boulevard to the south, Lasselle Street to the east, and Timo Street to the north. Most of the vegetation on the site consists of moderate to dense amounts of annual weeds/grasses throughout the subject site.

## **PROPOSED DEVELOPMENT AND GRADING**

The proposed commercial development is expected to consist of concrete, wood or steel framed one- and/or two-story structures utilizing slab on grade construction with associated streets, landscape areas, and utilities. The current development plans include three (3) building pads, a car wash, and fuel pump station positioned throughout the site. The plans provided by you were utilized in our evaluation and form the base for our Geotechnical Map, Plate 1.

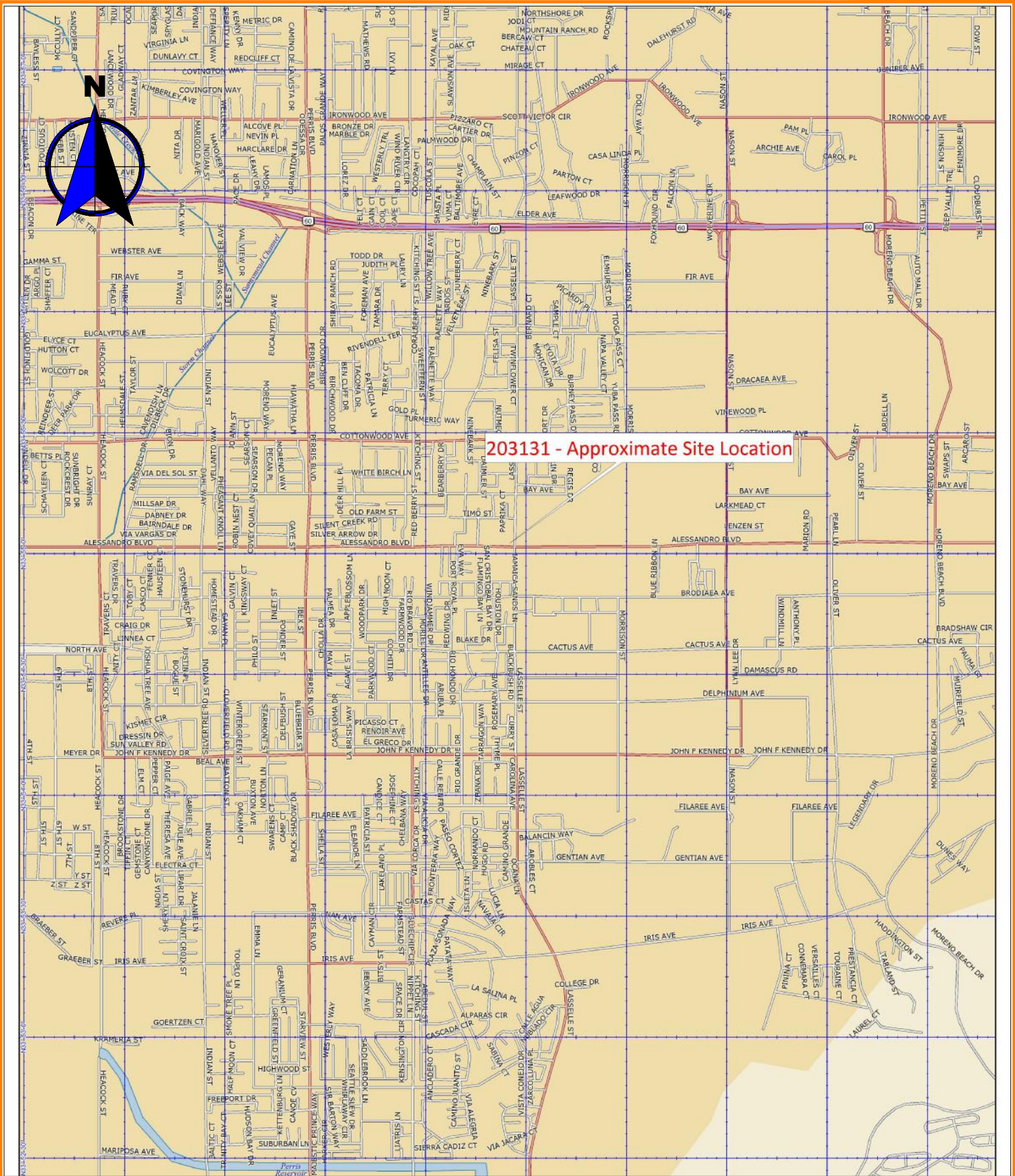

203131 - Approximate Site Location

© 2007 DeLorme (www.delorme.com) Topo USA®.

Earth Strata Geotechnical Services, Inc.  
 Geotechnical, Environmental and Materials Testing Consultants  
 www.ESGSINC.com (951) 397-8315

LASELLE STREET  
 VICINITY MAP

203131-10A  
 SCALE 1:40,625  
 JUNE 2020 FIGURE 1

## **FIELD EXPLORATION AND LABORATORY TESTING**

### **Field Exploration**

Subsurface exploration within the subject site was performed by Geoboden Inc., on December 2, 2017 for the exploratory excavations. A truck mounted hollow-stem-auger drill rig was utilized to drill eight (8) borings throughout the site to a maximum depth of 51.5 feet.

Associated with the subsurface exploration was the collection of bulk (disturbed) samples and relatively undisturbed samples of earth materials for laboratory testing and analysis. The relatively undisturbed samples were obtained with a 3 inch outside diameter modified California split-spoon sampler lined with 1-inch-high brass rings. Additional samples were retrieved using a Standard Penetration Test (N) split-spoon sampler. Samples obtained using a hollow stem auger drill rig, were mechanically driven with successive 30 inch drops of a 140-pound automatic trip safety hammer. The blow count per one-foot increment was recorded in the boring logs. The approximate exploratory locations are shown on Plate 1 and descriptive logs are presented in Appendix B.

### **Laboratory Testing**

Maximum dry density/optimum moisture content, expansion potential, pH, resistivity, sulfate content, chloride content, and in-situ density/moisture content were determined by Geoboden Inc., for selected undisturbed and bulk samples of earth materials, considered representative of those encountered. An evaluation of the test data is reflected throughout the Conclusions and Recommendations section of this report. A brief description of laboratory test criteria and summaries of test data are presented in Appendix C.

## **FINDINGS**

### **Regional Geology**

Regionally, the site is located in the Peninsular Ranges Geomorphic Province of California. The Peninsular Ranges are characterized by northwest trending steep mountain ranges separated by sediment filled elongated valleys. The dominant structural geologic features reflect the northwest trend of the province. Associated with and subparallel to the San Andreas Fault are the San Jacinto Fault, Newport-Inglewood, and the Whittier-Elsinore Fault. The Santa Ana Mountains abut the west side of the Elsinore Fault while the Perris Block forms the other side of the fault zone to the east. The Perris Block is bounded to the east by the San Jacinto Fault. The northern perimeter of the Los Angeles basin forms part of a northerly dipping blind thrust fault at the boundary between the Peninsular Ranges Province and the Transverse Range Province.

The mountainous regions within the Peninsular Ranges Province are comprised of Pre-Cretaceous, metasedimentary, and metavolcanic rocks along with Cretaceous plutonic rocks of the Southern California Batholith. The low lying areas are primarily comprised of Tertiary and Quaternary non-marine alluvial sediments consisting of alluvial deposits, sandstones, claystones, siltstones, conglomerates, and occasional volcanic units. A map illustrating the regional geology is presented on the Regional Geologic Map, Figure 2.

## **Local Geology**

The earth materials on the site are primarily comprised of Quaternary alluvial materials and Bedrock. A general description of the dominant earth materials observed on the site is provided below:

- Quaternary Very Old Fan Deposits (map symbol Qvof): Quaternary very old fan deposits were encountered to a maximum depth of 51.5 feet. These alluvial deposits consist predominately of interlayered yellowish brown to brown, fine to coarse grained silty sand and poorly graded sand with gravel. These deposits were generally noted to be in a slightly moist to moist, medium dense to dense state.

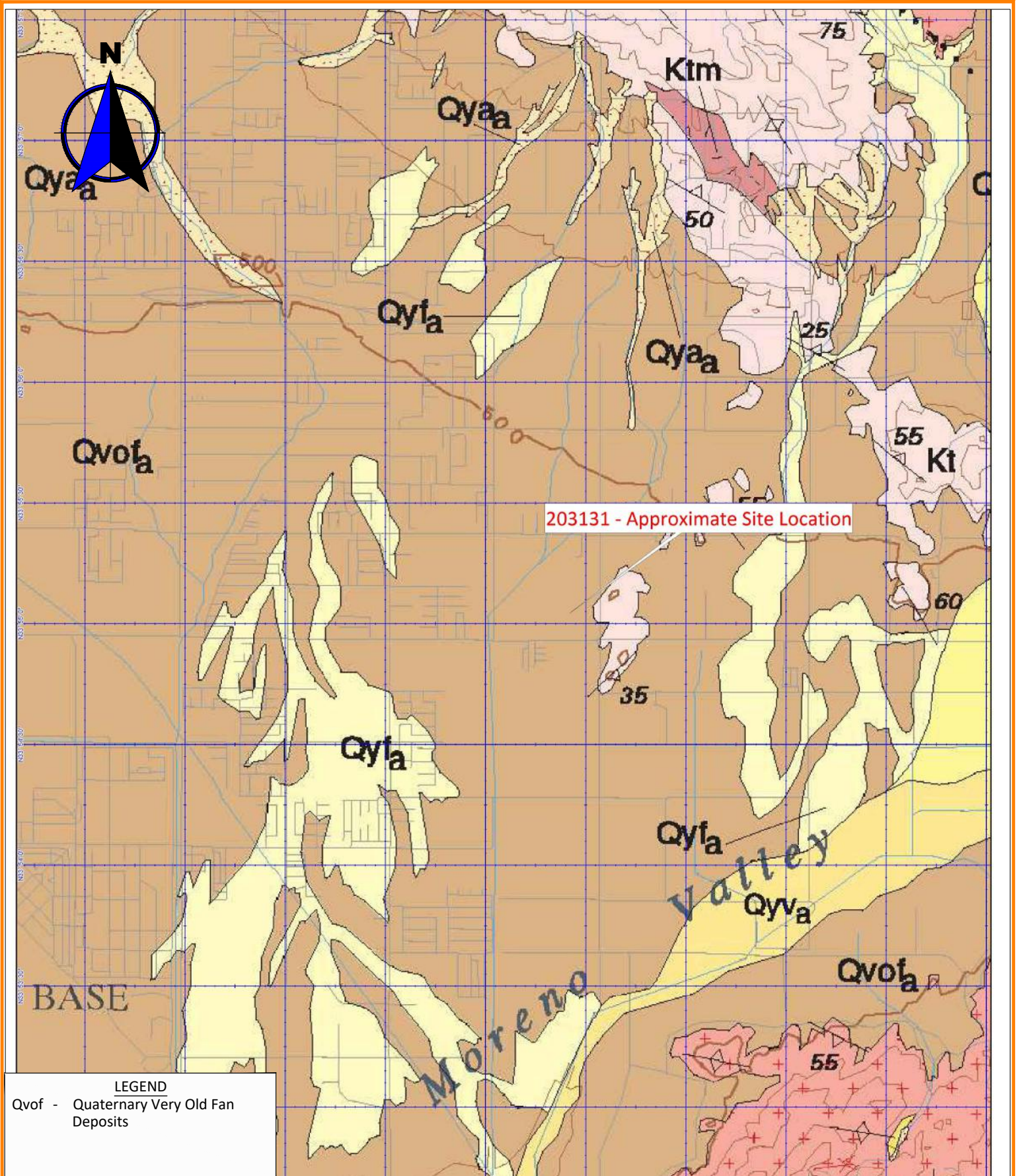

REFERENCES: Morton, D.M., Hauser, Rachel M., and Ruppert, Kelly R., 2004, Preliminary Digital Geologic Map of the San Bernardino and Santa Ana 30' x 60' Quadrangle, Southern California, Version 2.0: U.S. Geological Survey Open-File Report 99-0172.  
 "© 2007 DeLorme (www.delorme.com) Topo USA®".

Earth Strata Geotechnical Services, Inc. Geotechnical, Environmental and Materials Testing Consultants www.ESGSINC.com (951) 397-8315	LASELLE STREET		203131-10A
	REGIONAL GEOLOGIC MAP		SCALE 1:40,625
	JUNE 2020	FIGURE 2	

## **Faulting**

The project is located in a seismically active region and as a result, significant ground shaking will likely impact the site within the design life of the proposed project. The geologic structure of the entire southern California area is dominated by northwest-trending faults associated with the San Andreas Fault system, which accommodates for most of the right lateral movement associated with the relative motion between the Pacific and North American tectonic plates. Known active faults within this system include the Newport-Inglewood, Whittier-Elsinore, San Jacinto and San Andreas Faults.

No active faults are known to project through the site and the site is not located within an Alquist-Priolo Earthquake Fault Zone, established by the State of California to restrict the construction of new habitable structures across identifiable traces of known active faults. An active fault is defined by the State of California as having surface displacement within the past 11,000 years or during the Holocene geologic time period. Based on our mapping of the subject site, review of current and historical aerial imagery, lack of lineaments indicative of active faulting, and the data compiled during the preparation of this report, it is our interpretation that the potential for surface rupture to adversely impact the proposed structures is very low to remote.

Based on our review of regional geologic maps and applicable computer programs (USGS Seismic Design Maps, Caltrans ARS online, and USGS Earthquake Hazard Programs), the San Jacinto Fault with an approximate source to site distance of 6.73 kilometers is the closest known active fault anticipated to produce the highest ground accelerations, with an anticipated maximum modal magnitude of 7.7. A list of faults as well as a list of significant historical seismic events within a 100km radius of the subject site are included in Appendix D.

## **Landslides**

Landslide debris was not observed during our subsurface exploration and no ancient landslides are known to exist on the site. No landslides are known to exist, or have been mapped, in the vicinity of the site. Geologic mapping of the site conducted during our investigation, and review of aerial imagery of the site, reveal no geomorphic expressions indicative of landsliding.

## **CONCLUSIONS AND RECOMMENDATIONS**

### **General**

From geotechnical and engineering geologic points of view, the subject property is considered suitable for the proposed development, provided the following conclusions and recommendations are incorporated into the plans and are implemented during construction.

## **Earthwork**

### **Earthwork and Grading**

The provisions of the 2019 California Building Code (CBC), including the General Earthwork and Grading Specifications in the last Appendix of this report, should be applied to all earthwork and grading operations, as well as in accordance with all applicable grading codes and requirements of the appropriate reviewing agency. Unless specifically revised or amended herein, grading operations should also be performed in accordance with applicable provisions of our General Earthwork and Grading Specifications within the last appendix of this report.

### **Clearing and Grubbing**

Vegetation including trees, grasses, weeds, brush, shrubs, or any other debris should be stripped from the areas to be graded and properly disposed of offsite. In addition, laborers should be utilized to remove any roots, branches, or other deleterious materials during grading operations.

Earth Strata Geotechnical Services should be notified at the appropriate times to provide observation and testing services during Clearing and Grubbing operations. Any buried structures or unanticipated conditions should be brought to our immediate attention.

### **Excavation Characteristics**

Based on the results of our exploration and experience with similar projects in similar settings, the near surface earth materials, will be readily excavated with conventional earth moving equipment.

### **Groundwater**

Groundwater was not observed during the subsurface exploration performed by Geoboden. It should be noted that localized groundwater could be encountered during grading due to the limited number of exploratory locations or other factors.

### **Ground Preparation for Fill Areas**

For each area to receive compacted fill, the removal of low density, compressible earth materials, such as topsoil, upper alluvial materials, and undocumented artificial fill, should continue until firm competent alluvium is encountered. Removal excavations are subject to verification by the project engineer, geologist or their representative. Prior to placing compacted fills, the exposed bottom in each removal area should be scarified to a depth of 6 inches or more, watered or air dried as necessary to achieve near optimum moisture conditions and then compacted to a minimum of 90 percent of the maximum dry density determined by ASTM D 1557.

The intent of remedial grading is to diminish the potential for hydro-consolidation, slope instability, and/or settlement. Remedial grading should extend beyond the perimeter of the proposed structures a horizontal distance equal to the depth of excavation or a minimum of 5 feet, whichever is greater. For cursory purposes the anticipated removal depths are shown on the enclosed

Geotechnical Map, Plate 1. In general, the anticipated removal depths should vary from 3 to 6 feet below existing grade.

### **Wet Removals**

Wet alluvial materials will probably not be encountered within the low-lying areas of the site. If removals of wet alluvial materials are required, special grading equipment and procedures can greatly reduce overall costs. Careful planning by an experienced grading contractor can reduce the need for special equipment, such as swamp cats, draglines, excavators, pumps, and top loading earthmovers. Possible solutions may include the placement of imported angular rock and/or geotextile ground reinforcement. More specific recommendations can be provided based on the actual conditions encountered. Drying or mixing of wet materials with dry materials will be needed to bring the wet materials to near optimum moisture prior to placing wet materials into compacted fills.

### **Oversize Rock**

Oversize rock should be expected in the mapped area in the northeast portion of the site. Oversize rock that is encountered (i.e., rock exceeding a maximum dimension of 12 inches) should be disposed of offsite or stockpiled onsite and crushed for future use. The disposal of oversize rock is discussed in greater detail in General Earthwork and Grading Specifications within the last appendix of this report.

### **Compacted Fill Placement**

Compacted fill materials should be placed in 6 to 8 inch maximum (uncompacted) lifts, watered or air dried as necessary to achieve uniform near optimum moisture content and then compacted to a minimum of 90 percent of the maximum dry density determined by ASTM D 1557.

### **Import Earth Materials**

Should import earth materials be needed to achieve final design grades, all potential import materials should be free of deleterious/oversize materials, non-expansive, and approved by the project geotechnical consultant prior to delivery onsite.

### **Fill Slopes**

When properly constructed, fill slopes up to 10 feet high with inclinations of 2:1 (h:v) or flatter are considered to be grossly stable. Keyways are required at the toe of all fill slopes higher than 5 feet and steeper than 5:1 (h:v). Keyways should be a minimum of 10 feet wide and 2 feet into competent earth materials, as measured on the downhill side. In order to establish keyway removals, backcuts should be cut no steeper than 1:1 or as recommended by the geotechnical engineer or engineering geologist. Compacted fill should be benched into competent earth materials.



## **Cut Slopes**

When properly constructed, cut slopes into alluvium up to 10 feet high with inclinations of 2:1 (h:v) or flatter are considered grossly stable. Cut slopes should be observed by the engineering geologist or his representative during grading, but are anticipated to be stable.

## **Stabilization Fills**

Currently, stabilization fills will not be required for cut slopes in the alluvium. Our engineering geologist or his representative should be called to evaluate all slopes during grading. In the event that unfavorable geologic conditions are encountered, recommendations for stabilization fills or flatter slopes will be provided.

## **Fill Over Cut Slopes**

The fill portion of fill over cut slopes should not be constructed until the cut portion of the slope has been cut to finish grade. The earth materials and geologic structure exposed along the cut slope should be evaluated with regard to suitability for compacted fills or foundations and for stability. If the cut materials are determined to be competent, then the construction of the keyway and subdrain system may commence or additional remedial recommendations will be provided.

## **Temporary Backcuts**

It is the responsibility of the grading contractor to follow all Cal-OSHA requirements with regard to excavation safety. Where existing developments are upslope, adequate slope stability to protect those developments must be maintained. Temporary backcuts will be required to accomplish removals of unsuitable materials and possibly, to perform canyon removals, stabilization fills, and/or keyways. Backcuts should be excavated at a gradient of 1:1 (h:v) or flatter. Flatter backcuts may be required where geologic structure or earth materials are unfavorable. It is imperative that grading schedules minimize the exposure time of the unsupported excavations. All excavations should be stabilized within 30 days of initial excavation.

## **Cut/Fill Transitions**

Cut/fill transitions should be eliminated from all building areas where the depth of fill placed within the "fill" portion exceeds proposed footing depths. This is to diminish distress to structures resulting from excessive differential settlement. The entire foundation of each structure should be founded on a uniform bearing material. This should be accomplished by overexcavating the "cut" portion and replacing the excavated materials as properly compacted fill. Refer to the following table for recommended depths of overexcavation.

<b>DEPTH OF FILL ("fill" portion)</b>	<b>DEPTH OF OVEREXCAVATION ("cut" portion)</b>
Up to 5 feet	Equal Depth
5 to 10 feet	5 feet
Greater than 10 feet	One-half the thickness of fill placed on the "fill" portion (10 feet maximum)

Overexcavation of the “cut” portion should extend beyond the building perimeter a horizontal distance equal to the depth of overexcavation or a minimum of 5 feet, whichever is greater.

### **Cut Areas**

In cut areas, an area a minimum of 5 feet beyond the footprint of the proposed structures should overexcavated until; competent bottoms are achieved; to a minimum 3 feet below the proposed foundations; or per the Overexcavation Table above; (whichever is greater) and replaced with compacted fill. Final determination of areas that require overexcavation should be determined in the field by a representative of Earth Strata Geotechnical Services.

### **Shrinkage, Bulking and Subsidence**

Volumetric changes in earth material quantities will occur when poorly consolidated earth materials are replaced with properly compacted fill. Estimates of the percent shrinkage/bulking factors for the various geologic units observed on the subject property are based on in-place densities and on the estimated average percent of relative compaction achieved during grading.

<b>GEOLOGIC UNIT</b>	<b>SHRINKAGE (%)</b>
Alluvium	10 to 15
Bedrock	0 to 5 (bulking)

Subsidence from scarification and recompaction of exposed bottom surfaces is expected to be negligible to approximately 0.01 foot.

The estimates of shrinkage/bulking and subsidence are intended as an aid for project engineers in determining earthwork quantities. Since many variables can affect the accuracy of these estimates, they should be used with caution and contingency plans should be in place for balancing the project.

### **Geotechnical Observations**

Clearing operations, removal of unsuitable materials, and general grading procedures should be observed by the project geotechnical consultant or his representative. No compacted fill should be placed without observations by the geotechnical consultant or his representative to verify the adequacy of the removals.

The project geotechnical consultant or his representative should be present to observe grading operations and to check that minimum compaction requirements and proper lift thicknesses are being met, as well as to verify compliance with the other recommendations presented herein.

### **Post Grading Considerations**

#### **Slope Landscaping and Maintenance**

Adequate slope and building pad drainage is essential for the long term performance of the subject site. The gross stability of graded slopes should not be adversely affected, provided all drainage provisions are properly constructed and maintained. Engineered slopes should be landscaped with

deep rooted, drought tolerant maintenance free plant species, as recommended by the project landscape architect.

### **Site Drainage**

Control of site drainage is important for the performance of the proposed project. Roof gutters are recommended for the proposed structures. Pad and roof drainage should be collected and transferred to driveways, adjacent streets, storm-drain facilities, or other locations approved by the building official in non-erosive drainage devices. Drainage should not be allowed to pond on the pad or against any foundation or retaining wall. Drainage should not be allowed to flow uncontrolled over any descending slope. Planters located within retaining wall backfill should be sealed to prevent moisture intrusion into the backfill. Planters located next to structures should be sealed to the depth of the footings. Drainage control devices require periodic cleaning, testing and maintenance to remain effective.

At a minimum, pad drainage should be designed at the minimum gradients required by the CBC. To divert water away from foundations, the ground surface adjacent to foundations should also be graded at the minimum gradients required per the CBC.

### **Utility Trenches**

All utility trench backfill should be compacted at near optimum moisture to a minimum of 90 percent of the maximum dry density determined by ASTM D 1557. For utility trench backfill within pavement areas the upper 6 inches of subgrade materials should be compacted to 95 percent of the maximum dry density determined by ASTM D 1557. This includes within the street right-of-ways, utility easements, under footings, sidewalks, driveways and building floor slabs, as well as within or adjacent to any slopes. Backfill should be placed in approximately 6 to 8 inch maximum loose lifts and then mechanically compacted with a hydro-hammer, rolling with a sheepsfoot, pneumatic tampers, or similar equipment. The utility trenches should be tested by the project geotechnical engineer or their representative to verify minimum compaction requirements are obtained.

In order to minimize the penetration of moisture below building slabs, all utility trenches should be backfilled with compacted fill, lean concrete or concrete slurry where they undercut the perimeter foundation. Utility trenches that are proposed parallel to any building footings (interior and/or exterior trenches), should not be located within a 1:1 (h:v) plane projected downward from the outside bottom edge of the footing.

## **SEISMIC DESIGN CONSIDERATIONS**

### **Ground Motions**

Structures are required to be designed and constructed to resist the effects of seismic ground motions as provided in the 2019 California Building Code Section 1613. The design is dependent on the site class, occupancy category I, II, III, or IV, mapped spectral accelerations for short periods ( $S_s$ ), and mapped spectral acceleration for a 1-second period ( $S_1$ ).

In order for structural design to comply with the 2019 CBC, the USGS “US Seismic Design Maps” online tool was used to compile spectral accelerations for the subject property based on data and maps jointly compiled by the United States Geological Survey (USGS) and the California Geological Survey (CGS). The data found in the following table is based on the Maximum Considered Earthquake (MCE) with 5% damped ground motions having a 2% probability of being exceeded in 50 years (2,475 year return period).

The seismic design coefficients were determined by a combination of the site class, mapped spectral accelerations, and occupancy category. The following seismic design coefficients should be implemented during design of the proposed structures. Summaries of the Seismic Hazard Deaggregation graphs and test data are presented in Appendix D.

2019 CBC	FACTOR (ASCE 7-16)
Site Location	Latitude: 33.918369° (North) Longitude: -117.210555°(West)
Site Class	D
Mapped Spectral Accelerations for short periods, $S_s$	1.728 g
Mapped Spectral Accelerations for 1-Second Period, $S_1$	0.675 g
Maximum Considered Earthquake Spectral Response Acceleration for Short Periods, $S_{ms}$	2.074 g
Maximum Considered Earthquake Spectral Response Acceleration for 1-Second Period, $S_{m1}$	*Null See Section 11.4.8
Design Spectral Response Acceleration for Short Periods, $S_{Ds}$	1.382 g
Design Spectral Response Acceleration for 1-Second Period, $S_{D1}$	*Null See Section 11.4.8
Seismic Design Category	D
Importance Factor Based on Occupancy Category	II

\*2019 CBC

We performed the probabilistic seismic hazard assessment for the site in accordance with the 2019 CBC, Section 1803.5.11 and 1803.5.12. The probabilistic seismic hazard maps and data files were jointly prepared by the United States Geological Survey (USGS) and the California Geological Survey (CGS) and can be found at the CGS Probabilistic Seismic Hazards Mapping Ground Motion Page. Actual ground shaking intensities at the site may be substantially higher or lower based on complex variables such as the near source directivity effects, depth and consistency of earth materials, topography, geologic structure, direction of fault rupture, and seismic wave reflection, refraction, and attenuation rates. The mean peak ground acceleration was calculated to be 0.877 g.

### **Secondary Seismic Hazards**

Secondary effects of seismic shaking considered as potential hazards include several types of ground failure as well as induced flooding. Different types of ground failure, which could occur as a consequence of severe ground shaking at the site, include landslides, ground lurching, shallow ground rupture, and liquefaction/lateral spreading. The probability of occurrence of each type of ground failure depends on the severity of the earthquake, distance from faults, topography, the state of subsurface earth materials, groundwater conditions, and other factors. Based on our experience, subsurface exploration, and laboratory testing, all of the above secondary effects of seismic activity are considered unlikely.

Seismically induced flooding is normally a consequence of a tsunami (seismic sea wave), a seiche (i.e., a wave-like oscillation of surface water in an enclosed basin that may be initiated by a strong earthquake) or failure of a major reservoir or retention system up gradient of the site. Since the site is at an elevation of more than 1,580 feet above mean sea level and is located more than 42 miles inland from the nearest coastline of the Pacific Ocean, the potential for seismically induced flooding due to a tsunami is considered nonexistent. Since no enclosed bodies of water lie adjacent to or up gradient of the site, the likelihood for induced flooding due to a dam failure or a seiche overcoming the dam's freeboard is considered nonexistent.

### **Liquefaction and Lateral Spreading**

Liquefaction occurs as a result of a substantial loss of shear strength or shearing resistance in loose, saturated, cohesionless earth materials subjected to earthquake induced ground shaking. Potential impacts from liquefaction include loss of bearing capacity, liquefaction related settlement, lateral movements, and surface manifestation such as sand boils. Seismically induced settlement occurs when loose sandy soils become denser when subjected to shaking during an earthquake. The three factors determining whether a site is likely to be subject to liquefaction include seismic shaking, type and consistency of earth materials, and groundwater level. The proposed structures will be supported by compacted fill and competent alluvium, with no shallow groundwater. As such, the potential for earthquake induced liquefaction and lateral spreading beneath the proposed structures is considered very low to remote due to the recommended compacted fill, relatively low groundwater level, and the dense nature of the deeper onsite earth materials.

## **TENTATIVE FOUNDATION DESIGN RECOMMENDATIONS**

### **General**

Provided grading is performed in accordance with the recommendations of this report, shallow foundations are considered feasible for support of the proposed structures. Tentative foundation recommendations are provided herein and graphic presentations of relevant recommendations may also be included on the enclosed map.

### **Allowable Bearing Values**

An allowable bearing value of 2,500 pounds per square foot (psf) is recommended for design of 24-inch square pad footings and 12-inch-wide continuous footings founded at a minimum depth of 12 inches below the lowest adjacent final grade. This value may be increased by 20 percent for each additional 1-foot of width and/or depth to a maximum value of 3,000 psf. Recommended allowable bearing values include both dead and frequently applied live loads and may be increased by one third when designing for short duration wind or seismic forces.

### **Settlement**

Based on the settlement characteristics of the earth materials that underlie the building sites and the anticipated loading, we estimate that the maximum total settlement of the footings will be less than approximately  $\frac{3}{4}$  inch. Differential settlement is expected to be about  $\frac{1}{2}$  inch over a horizontal distance of

approximately 20 feet, for an angular distortion ratio of 1:480. It is anticipated that the majority of the settlement will occur during construction or shortly after the initial application of loading.

The above settlement estimates are based on the assumption that the grading and construction are performed in accordance with the recommendations presented in this report and that the project geotechnical consultant will observe or test the earth material conditions in the footing excavations.

### **Lateral Resistance**

Passive earth pressure of 250 psf per foot of depth to a maximum value of 2,500 psf may be used to establish lateral bearing resistance for footings. For areas covered with hardscape, passive earth pressure may be taken from the surface. For areas without hardscape, the upper twelve inches of the soil profile must be neglected when calculating passive earth pressure. A coefficient of friction of 0.36 times the dead load forces may be used between concrete and the supporting earth materials to determine lateral sliding resistance. The above values may be increased by one-third when designing for short duration wind or seismic forces. When combining passive and friction for lateral resistance, the passive component should be reduced by one third. In no case shall the lateral sliding resistance exceed one-half the dead load for clay, sandy clay, sandy silty clay, silty clay, and clayey silt.

The above lateral resistance values are based on footings for an entire structure being placed directly against either compacted fill or competent alluvium.

### **Structural Setbacks and Building Clearance**

Structural setbacks are required per the 2019 California Building Code (CBC). Additional structural setbacks are not required due to geologic or geotechnical conditions within the site. Improvements constructed in close proximity to natural or properly engineered and compacted slopes can, over time, be affected by natural processes including gravity forces, weathering, and long term secondary settlement. As a result, the CBC requires that buildings and structures be setback or footings deepened to resist the influence of these processes.

For structures that are planned near ascending and descending slopes, the footings should be embedded to satisfy the requirements presented in the CBC, Section 1808.7 as illustrated in the following Foundation Clearances from Slopes diagram.

## FOUNDATION CLEARANCES FROM SLOPES

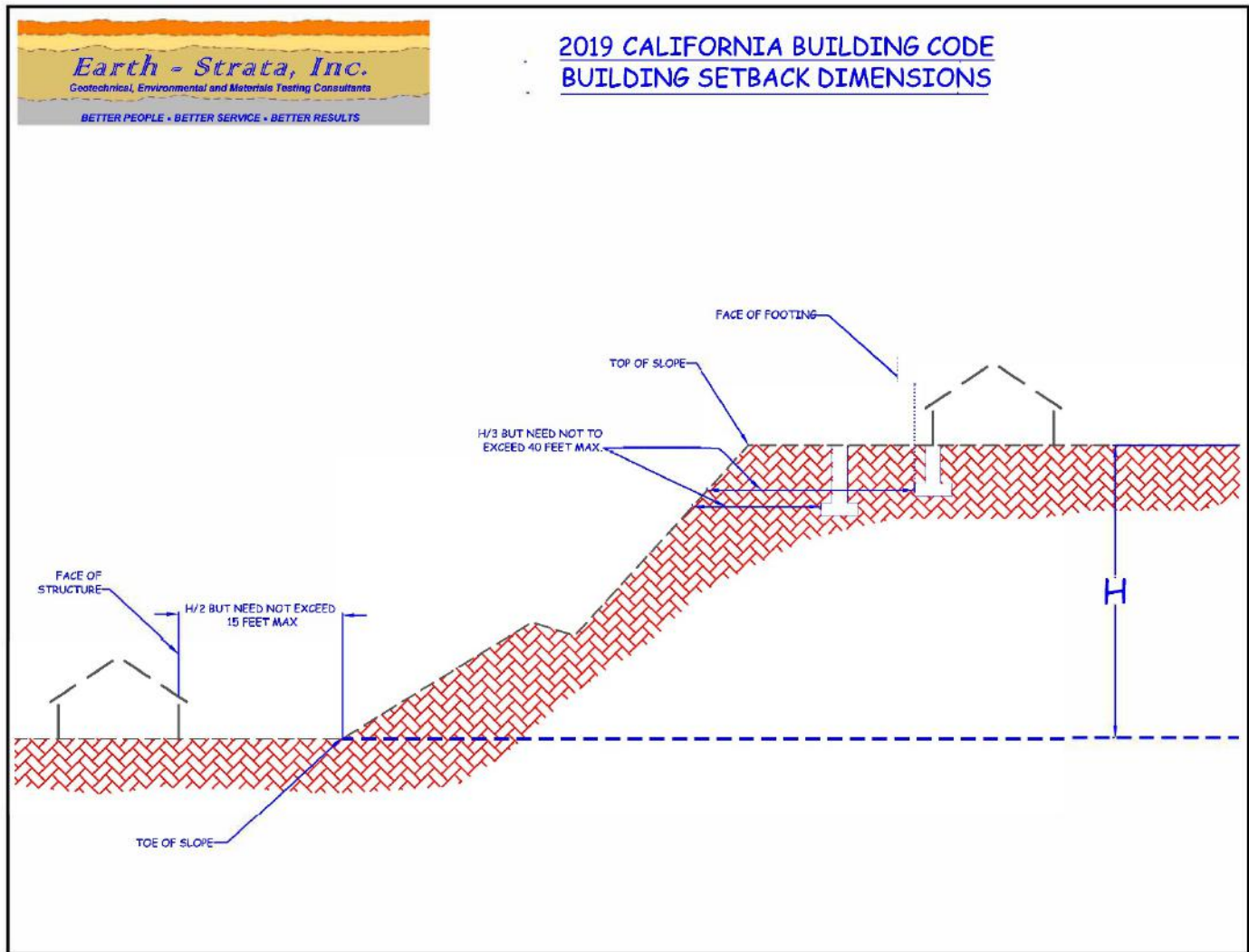

When determining the required clearance from ascending slopes with a retaining wall at the toe, the height of the slope shall be measured from the top of the wall to the top of the slope.

### **Foundation Observations**

In accordance with the 2019 CBC and prior to the placement of forms, concrete, or steel, all foundation excavations should be observed by the geologist, engineer, or his representative to verify that they have been excavated into competent bearing materials. The excavations should be per the approved plans, moistened, cleaned of all loose materials, trimmed neat, level, and square. Any moisture softened earth materials should be removed prior to steel or concrete placement.

Earth materials from foundation excavations should not be placed in slab on grade areas unless the materials are tested for expansion potential and compacted to a minimum of 90 percent of the maximum dry density.

## **Expansive Soil Considerations**

Analysis and review of the boring logs performed by Geoboden indicate onsite earth materials likely exhibit an expansion potential of **VERY LOW** as classified in accordance with 2019 CBC Section 1803.5.3 and ASTM D 4829. Additional, testing for expansive soil conditions should be conducted upon completion of rough grading. The following recommendations should be considered the very minimum requirements, for the earth materials tested. It is common practice for the project architect or structural engineer to require additional slab thickness, footing sizes, and/or reinforcement.

### **Very Low Expansion Potential (Expansion Index of 20 or Less)**

Our laboratory test results indicate that the earth materials onsite exhibit a **VERY LOW** expansion potential as classified in accordance with 2019 CBC Section 1803.5.3 and ASTM D 4829. Since the onsite earth materials exhibit expansion indices of 20 or less, the design of slab on ground foundations is exempt from the procedures outlined in Section 1808.6.1 or 1808.6.2.

#### **Footings**

- Exterior continuous footings may be founded at the minimum depths below the lowest adjacent final grade (i.e. 18-inch minimum depth for one and two-story, and 24-inch minimum depth for three-story construction). Interior continuous footings for one-, two-, and three-story construction may be founded at a minimum depth of 12 inches below the lowest adjacent final grade. All continuous footings should have a minimum width of 12, 15, and 18 inches, for one-, two-, and three-story structures, respectively per Table 1809.7 of the 2019 CBC, and should be reinforced with a minimum of four (4) No. 4 bars, two (2) top and two (2) bottom.
- Exterior pad footings intended to support roof overhangs, such as second story decks, patio covers and similar construction should be a minimum of 24 inches square and founded at a minimum depth of 18 inches below the lowest adjacent final grade. No special reinforcement of the pad footings will be required.

#### **Building Floor Slabs**

- Building floor slabs should be a minimum of 5 inches thick and reinforced with a minimum of No. 3 bars spaced a maximum of 18 inches on center, each way. All floor slab reinforcement should be supported on concrete chairs or bricks to ensure the desired placement at mid-depth.
- Interior floor slabs, within moisture sensitive areas, should be underlain by a minimum 10-mil thick moisture/vapor barrier to help reduce the upward migration of moisture from the underlying earth materials. The moisture/vapor barrier used should meet the performance standards of an ASTM E 1745 Class A material, and be properly installed in accordance with ACI publication 318. It is the responsibility of the contractor to ensure that the moisture/vapor barriers are free of openings, rips, or punctures prior to placing concrete. As an option for additional moisture reduction, higher strength concrete, such as a minimum 28-day compressive strength of 5,000 pounds per square inch (psi) may be used. Ultimately, the design of the moisture/vapor barrier system and recommendations for concrete placement and curing are the purview of the foundation engineer, taking into consideration the project requirements



provided by the architect and owner.

- Garage floor slabs should be a minimum of 5 inches thick and should be reinforced in a similar manner as living area floor slabs. Garage floor slabs should be placed separately from adjacent wall footings with a positive separation maintained with  $\frac{3}{8}$  inch minimum felt expansion joint materials and quartered with weakened plane joints. A 12-inch-wide turn down founded at the same depth as adjacent footings should be provided across garage entrances. The turn down should be reinforced with a minimum of four (4) No. 4 bars, two (2) top and two (2) bottom.
- The subgrade earth materials below all floor slabs should be pre-watered to promote uniform curing of the concrete and minimize the development of shrinkage cracks, prior to placing concrete. The pre-watering should be verified by Earth Strata Geotechnical Services during construction.

### **Corrosivity**

Corrosion is defined by the National Association of Corrosion Engineers (NACE) as “a deterioration of a substance or its properties because of a reaction with its environment.” From a geotechnical viewpoint, the “substances” are the reinforced concrete foundations or buried metallic elements (not surrounded by concrete) and the “environment” is the prevailing earth materials in contact with them. Many factors can contribute to corrosivity, including the presence of chlorides, sulfates, salts, organic materials, different oxygen levels, poor drainage, different soil types, and moisture content. It is not considered practical or realistic to test for all of the factors which may contribute to corrosivity.

The potential for concrete exposure to chlorides is based upon the recognized Caltrans reference standard “Bridge Design Specifications”, under Subsection 8.22.1 of that document, Caltrans has determined that “Corrosive water or soil contains more than 500 parts per million (ppm) of chlorides”. Based on limited laboratory testing, the onsite earth materials have chloride contents *less* than 500 ppm. As such, specific requirements resulting from elevated chloride contents are not required.

Specific guidelines for concrete mix design are provided in 2019 CBC Section 1904.1 and ACI 318, Section 4.3 Table 4.3.1 when the soluble sulfate content of earth materials exceeds 0.1 percent by weight. Based on limited preliminary laboratory testing, the onsite earth materials are classified in accordance with Table 4.3.1 as having a *negligible* sulfate exposure condition. Therefore, structural concrete in contact with onsite earth materials should utilize Type I or II.

Based on laboratory testing of resistivity by Geoboden, the onsite earth materials in contact with buried steel should be considered *moderately corrosive*. Additionally, pH values below 5.6 and above 9.1 are recognized as being corrosive to many common metallic components. The pH values for the earth materials tested were *lower* than 9.1 and *higher* than 5.6.

The preliminary test results for corrosivity are based on limited samples, and the initiation of grading may blend various earth materials together. This blending or imported material could alter and increase the detrimental properties of the onsite earth materials. Accordingly, additional testing for chlorides and sulfates along with testing for pH and resistivity should be performed upon completion of grading. Laboratory test results are presented in Appendix C.

## RETAINING WALLS

### Active and At-Rest Earth Pressures

Foundations may be designed in accordance with the recommendations provided in the Tentative Foundation Design Recommendation section of this report. The following table provides the minimum recommended equivalent fluid pressures for design of retaining walls a maximum of 8 feet high. The active earth pressure should be used for design of unrestrained retaining walls, which are free to tilt slightly. The at-rest earth pressure should be used for design of retaining walls that are restrained at the top, such as basement walls, curved walls with no joints, or walls restrained at corners. For curved walls, active pressure may be used if tilting is acceptable and construction joints are provided at each angle point and at a minimum of 15 foot intervals along the curved segments.

MINIMUM STATIC EQUIVALENT FLUID PRESSURES (pcf)		
PRESSURE TYPE	BACKSLOPE CONDITION	
	LEVEL	2:1 (h:v)
Active Earth Pressure	40	63
At-Rest Earth Pressure	60	95

The retaining wall parameters provided do not account for hydrostatic pressure behind the retaining walls. Therefore, the subdrain system is a very important part of the design. All retaining walls should be designed to resist surcharge loads imposed by other nearby walls, structures, or vehicles should be added to the above earth pressures, if the additional loads are being applied within a 1.5:1 (h:v) plane projected up from the heel of the retaining wall footing. As a way of minimizing surcharge loads and the settlement potential of nearby buildings, the footings for the building can be deepened below the 1.5:1 (h:v) plane projected up from the heel of the retaining wall footing.

Upon request and under a separate scope of work, more detailed analyses can be performed to address equivalent fluid pressures with regard to stepped retaining walls, actual retaining wall heights, actual backfill inclinations, specific backfill materials, higher retaining walls requiring earthquake design motions, etc.

### Subdrain System

We recommend a perforated pipe and gravel subdrain system be provided behind all proposed retaining walls to prevent the buildup of hydrostatic pressure behind the proposed retaining walls. The perforated pipe should consist of 4-inch minimum diameter Schedule 40 PVC or ABS SDR-35, placed with the perforations facing down. The pipe should be surrounded by 1 cubic foot per foot of ¾- or 1½ inch open graded gravel wrapped in filter fabric. The filter fabric should consist of Mirafi 140N or equivalent to prevent infiltration of fines and subsequent clogging of the subdrain system.

In lieu of a perforated pipe and gravel subdrain system, weep holes or open vertical masonry joints may be provided in the lowest row of block exposed to the air to prevent the buildup of hydrostatic pressure behind the proposed retaining walls. Weep holes should be a minimum of 3 inches in diameter and provided at intervals at least every 6 feet along the wall. Open vertical masonry joints should be provided

at a minimum of 32 inch intervals. A continuous gravel fill, a minimum of 1 cubic foot per foot, should be placed behind the weep holes or open masonry joints. The gravel should be wrapped in filter fabric consisting of Mirafi 140N or equivalent.

The retaining walls should be adequately coated on the backfilled side of the walls with a proven waterproofing compound by an experienced professional to inhibit infiltration of moisture through the walls.

### **Temporary Excavations**

All excavations should be made in accordance with Cal-OSHA requirements. Earth Strata Geotechnical Services is not responsible for job site safety.

### **Retaining Wall Backfill**

Retaining wall backfill materials should be approved by the geotechnical engineer or his representative prior to placement as compacted fill. Retaining wall backfill should be placed in lifts no greater than 6 to 8 inches, watered or air dried as necessary to achieve near optimum moisture contents. All retaining wall backfill should be compacted to a minimum of 90 percent of the maximum dry density as determined by ASTM D 1557. Retaining wall backfill should be capped with a paved surface drain.

## **CONCRETE FLATWORK**

### **Thickness and Joint Spacing**

Concrete sidewalks and patio type slabs should be at least 3½ inches thick and provided with construction or expansion joints every 6 feet or less, to reduce the potential for excessive cracking. Concrete driveway slabs should be at least 5 inches thick and provided with construction or expansion joints every 10 feet or less.

### **Subgrade Preparation**

In order to reduce the potential for unsightly cracking, subgrade earth materials underlying concrete flatwork should be compacted at near optimum moisture to a minimum of 90 percent of the maximum dry density determined by ASTM D 1557 and then moistened to optimum or slightly above optimum moisture content. This moisture should extend to a depth of 12 inches below subgrade and be maintained prior to placement of concrete. Pre-watering of the earth materials prior to placing concrete will promote uniform curing of the concrete and minimize the development of shrinkage cracks. The project geotechnical engineer or his representative should verify the density and moisture content of the earth materials and the depth of moisture penetration prior to placing concrete.

Cracking within concrete flatwork is often a result of factors such as the use of too high a water to cement ratio and/or inadequate steps taken to prevent moisture loss during the curing of the concrete. Concrete distress can be reduced by proper concrete mix design and proper placement and curing of the concrete. Minor cracking within concrete flatwork is normal and should be expected.

## **PRELIMINARY ASPHALTIC CONCRETE PAVEMENT DESIGN**

Based on the geotechnical knowledge of the onsite earth material an assumed R-value of 20 may be used for preliminary pavement design. The following table includes our minimum recommended asphaltic concrete pavement sections calculated in accordance with the State of California design procedures using assumed Traffic Indices. Final pavement design should be based on sampling and testing of post grading conditions.

<b>PRELIMINARY ASPHALTIC CONCRETE PAVEMENT DESIGN</b>		
<b>PARAMETERS</b>	<b>MINOR LOCAL PARKING/AUTO DRIVES</b>	<b>COLLECTOR ENTRANCES/DRIVEWAYS</b>
Traffic Index	6.0	7.0
Assumed R-Value	20	20
AC Thickness (ft)	*0.25	*0.30
AB Thickness (ft)	*0.50	*0.50

\*Notes minimum section

<b>PRELIMINARY ASPHALTIC CONCRETE PAVEMENT DESIGN</b>	
<b>Alessandro Boulevard Lasselle Street</b>	
<b>PARAMETERS</b>	<b>Arterial</b>
Traffic Index	10
Assumed R-Value	20
AC Thickness (ft)	*0.5
AB Thickness (ft)	*1.00

\*Notes minimum section

Per city requirements coring of the existing sections will be required prior to final design

The subgrade earth materials immediately below the aggregate base (base) should be compacted to a minimum of 95 percent of the maximum dry density determined by ASTM D 1557 to a minimum depth of 12 inches. Base materials should be compacted to a minimum of 95 percent of the maximum dry density determined by ASTM D 1557.

Base materials should consist of Class 2 aggregate base conforming to Section 26-1.02B of the State of California Standard Specifications or crushed aggregate base conforming to Section 200-2 of the Standard Specifications for Public Works Construction (Greenbook). Base materials should be compacted at or slightly below optimum moisture content. Asphaltic concrete materials and construction operations should conform to Section 203 of the Greenbook.

## **GRADING PLAN REVIEW AND CONSTRUCTION SERVICES**

This report has been prepared for the exclusive use of **Mr. Alex Hann** and their authorized representative. It likely does not contain sufficient information for other parties or other uses. Earth Strata Geotechnical Services should be engaged to review the final design plans and specifications prior to construction. This is to verify that the recommendations contained in this report have been properly incorporated into the project plans and specifications. Should Earth Strata Geotechnical Services not be accorded the opportunity to review the project plans and specifications, we are not responsible for misinterpretation of our recommendations.

We recommend that Earth Strata Geotechnical Services be retained to provide geologic and geotechnical engineering services during grading and foundation excavation phases of the work. In order to allow for design changes in the event that the subsurface conditions differ from those anticipated prior to construction.

Earth Strata Geotechnical Services should review any changes in the project and modify and approve in writing the conclusions and recommendations of this report. This report and the drawings contained within are intended for design input purposes only and are not intended to act as construction drawings or specifications. In the event that conditions encountered during grading or construction operations appear to be different than those indicated in this report, this office should be notified immediately, as revisions may be required.

### **REPORT LIMITATIONS**

Our services were performed using the degree of care and skill ordinarily exercised, under similar circumstances, by reputable soils engineers and geologists, practicing at the time and location this report was prepared. No other warranty, expressed or implied, is made as to the conclusions and professional advice included in this report.

Earth materials vary in type, strength, and other geotechnical properties between points of observation and exploration. Groundwater and moisture conditions can also vary due to natural processes or the works of man on this or adjacent properties. As a result, we do not and cannot have complete knowledge of the subsurface conditions beneath the subject property. No practical study can completely eliminate uncertainty with regard to the anticipated geotechnical conditions in connection with a subject property. The conclusions and recommendations within this report are based upon the findings at the points of observation and are subject to confirmation by Earth Strata Geotechnical Services based on the conditions revealed during grading and construction.

This report was prepared with the understanding that it is the responsibility of the owner or their representative, to ensure that the conclusions and recommendations contained herein are brought to the attention of the other project consultants and are incorporated into the plans and specifications. The owners' contractor should properly implement the conclusions and recommendations during grading and construction, and notify the owner if they consider any of the recommendations presented herein to be unsafe or unsuitable.

**APPENDIX A**  
**REFERENCES**

## APPENDIX A

### References

California Building Standards Commission, 2019, *2019 California Building Code, California Code of Regulations Title 24, Part 2, Volume 2 of 2*, Based on 2018 International Building Code.

California Corrosion Guidelines

DeLorme, 2004, (www.delorme.com) *Topo USA*®.

Geoboden Inc., 2017, *Geotechnical Investigation Report, Proposed 76 Gas Station, Northwest Alessandro Boulevard/Lasselle Street, Moreno Valley, California*, Dated December 8.

Morton, D.M., Hauser, Rachel M., and Ruppert, Kelly R., 2004, *Preliminary Digital Geologic Map of the Santa Ana 30' x 60' Quadrangle, Southern California, Version 2.0*: U.S. Geological Survey Open-File Report 99-0172.

Morton, D.M. (compiler), and Fred K. Miller (compiler), 2003, *Preliminary Geologic Map of the San Bernardino 30' x 60' Quadrangle, California*: U.S. Geological Survey Open-File report 03-293, U.S. Geological Survey, Menlo Park, California.

Morton, D.M. (compiler), and Fred K. Miller (compiler), 2006, *Geologic Map of the San Bernardino and Santa Ana 30' x 60' Quadrangles, California*: U.S. Geological Survey, Version 1, California.

National Association of Corrosion Engineers, 1984, *Corrosion Basics An Introduction*, page 191.

Per A.B. Chance® Recommendations, 2003

**APPENDIX B**  
**EXPLORATORY LOGS**



**CLIENT** Northwest Moreno Properties Inc  
**PROJECT NUMBER** Moreno Valley-1-01  
**DATE STARTED** 12/2/17 **COMPLETED** 12/2/17  
**DRILLING CONTRACTOR** GeoBoden, Inc.  
**DRILLING METHOD** HSA  
**LOGGED BY** C.R. **CHECKED BY** \_\_\_\_\_  
**NOTES** \_\_\_\_\_

**PROJECT NAME** Proposed 76 Gas Station  
**PROJECT LOCATION** Alessandro Boulevard/Laselle Street, Moreno Valley  
**GROUND ELEVATION** \_\_\_\_\_ **HOLE SIZE** 8 inches  
**GROUND WATER LEVELS:**  
**AT TIME OF DRILLING** ---  
**AT END OF DRILLING** ---  
**AFTER DRILLING** ---

DEPTH (ft)	GRAPHIC LOG	MATERIAL DESCRIPTION	SAMPLE TYPE NUMBER	RECOVERY % (RQD)	BLOW COUNTS (N VALUE)	POCKET PEN. (tsf)	DRY UNIT WT. (pcf)	MOISTURE CONTENT (%)	ATTERBERG LIMITS			FINES CONTENT (%)
									LIQUID LIMIT	PLASTIC LIMIT	PLASTICITY INDEX	
0		SILTY SAND (SM): light brown, dry, ~70% sand, ~20% fines, ~10% gravel										
5		POORLY-GRADED SAND w. SILT & GRAVEL (SP-SM): yellowish brown, moist, ~15% fine subrounded gravel up to 1/2 inch, medium to coarse sand, ~10% fines	MC R-1		30		110	5				
10			SS S-2		22							
15		POORLY-GRADED SAND (SP): yellowish brown, moist, ~10% fine to coarse gravel, ~5% fines, ~85% medium to coarse sand	MC R-3		55							
20		POORLY-GRADED SAND w. GRAVEL (SP): yellowish brown, moist, ~15% fine to coarse gravel, ~5% fines, ~80% medium to coarse sand	SS S-4		58							
25		~30% fine to coarse gravel up to 1 inch, ~5% fines, ~65% medium to coarse sand	SS R-5		60							
30		POORLY-GRADED SAND w. GRAVEL (SP): brown, moist, ~15% fine gravel, ~5% fines, ~80% medium to coarse sand	SS S-6		60							
35												

GEOTECH BH COLUMNS - GINT STD US LAB.GDT - 12/7/17 22:10 - C:\PASSPORT\GIBI\76 GAS STATION\LOGS.GPJ

**CLIENT** Northwest Moreno Properties Inc **PROJECT NAME** Proposed 76 Gas Station  
**PROJECT NUMBER** Moreno Valley-1-01 **PROJECT LOCATION** Alessandro Boulevard/Laselle Street, Moreno Valley

DEPTH (ft)	GRAPHIC LOG	MATERIAL DESCRIPTION	SAMPLE TYPE NUMBER	RECOVERY % (RQD)	BLOW COUNTS (N VALUE)	POCKET PEN. (tsf)	DRY UNIT WT. (pcf)	MOISTURE CONTENT (%)	ATTERBERG LIMITS			FINES CONTENT (%)
									LIQUID LIMIT	PLASTIC LIMIT	PLASTICITY INDEX	
35		POORLY-GRADED SAND w. GRAVEL (SP): brown, moist, ~15% fine gravel, ~5% fines, ~80% medium to coarse sand (continued)										
40												
45												
50												

Bottom of borehole at 51.5 feet below ground surface. Boring was backfilled with cuttings. No groundwater was encountered at the time of drilling.

Bottom of borehole at 51.5 feet.

**CLIENT** Northwest Moreno Properties Inc  
**PROJECT NUMBER** Moreno Valley-1-01  
**DATE STARTED** 12/2/17 **COMPLETED** 12/2/17  
**DRILLING CONTRACTOR** GeoBoden, Inc.  
**DRILLING METHOD** HSA  
**LOGGED BY** C.R. **CHECKED BY** \_\_\_\_\_  
**NOTES** \_\_\_\_\_

**PROJECT NAME** Proposed 76 Gas Station  
**PROJECT LOCATION** Alessandro Boulevard/Laselle Street, Moreno Valley  
**GROUND ELEVATION** \_\_\_\_\_ **HOLE SIZE** 8 inches  
**GROUND WATER LEVELS:**  
**AT TIME OF DRILLING** ---  
**AT END OF DRILLING** ---  
**AFTER DRILLING** ---



DEPTH (ft)	GRAPHIC LOG	MATERIAL DESCRIPTION	SAMPLE TYPE NUMBER	RECOVERY % (RQD)	BLOW COUNTS (N VALUE)	POCKET PEN. (tsf)	DRY UNIT WT. (pcf)	MOISTURE CONTENT (%)	ATTERBERG LIMITS			FINES CONTENT (%)
									LIQUID LIMIT	PLASTIC LIMIT	PLASTICITY INDEX	
0												
5		SILTY SAND w. GRAVEL (SM): brown, dry, ~15% fine to coarse gravel, ~55% fine sand, ~30% fines	MC R-1		50		103	4				51
10		POORLY-GRADED SAND w. SILT & GRAVEL (SP-SM): brown, moist, ~15% fine gravel, ~10% fines, ~75% medium to coarse sand	SS S-2		36			3				
15		POORLY-GRADED SAND w. GRAVEL (SP): brown, moist, ~30% fine subrounded gravel up to 1/2 inch, ~5% fines, ~65% medium to coarse sand	MC R-3		50		111	2				

Bottom of borehole at 16.5 feet below ground surface. Boring was backfilled with cuttings. No groundwater was encountered at the time of drilling.

Bottom of borehole at 16.5 feet.

CLIENT Northwest Moreno Properties Inc  
 PROJECT NUMBER Moreno Valley-1-01  
 DATE STARTED 12/2/17 COMPLETED 12/2/17  
 DRILLING CONTRACTOR GeoBoden, Inc.  
 DRILLING METHOD HSA  
 LOGGED BY C.R. CHECKED BY \_\_\_\_\_  
 NOTES \_\_\_\_\_

PROJECT NAME Proposed 76 Gas Station  
 PROJECT LOCATION Alessandro Boulevard/Laselle Street, Moreno Valley  
 GROUND ELEVATION \_\_\_\_\_ HOLE SIZE 8 inches  
 GROUND WATER LEVELS:  
 AT TIME OF DRILLING ---  
 AT END OF DRILLING ---  
 AFTER DRILLING ---

DEPTH (ft)	GRAPHIC LOG	MATERIAL DESCRIPTION	SAMPLE TYPE NUMBER	RECOVERY % (RQD)	BLOW COUNTS (N VALUE)	POCKET PEN. (tsf)	DRY UNIT WT. (pcf)	MOISTURE CONTENT (%)	ATTERBERG LIMITS			FINES CONTENT (%)
									LIQUID LIMIT	PLASTIC LIMIT	PLASTICITY INDEX	
0												
5		SILTY SAND (SM): brown, dry, ~70% sand, ~30% fines	MC R-1		50		108	3				52
10		POORLY-GRADED SAND w. SILT & GRAVEL (SP-SM): light yellowish brown, moist, ~15% fine subrounded gravel, ~10% fines, ~75% medium to coarse sand	SS S-2		43			2				
15			MC R-3		45		111	3				

Bottom of borehole at 16.5 feet below ground surface. Boring was backfilled with cuttings. No groundwater was encountered at the time of drilling.

Bottom of borehole at 16.5 feet.

CLIENT Northwest Moreno Properties Inc  
 PROJECT NUMBER Moreno Valley-1-01  
 DATE STARTED 12/2/17 COMPLETED 12/2/17  
 DRILLING CONTRACTOR GeoBoden, Inc.  
 DRILLING METHOD HSA  
 LOGGED BY C.R. CHECKED BY \_\_\_\_\_  
 NOTES \_\_\_\_\_

PROJECT NAME Proposed 76 Gas Station  
 PROJECT LOCATION Alessandro Boulevard/Laselle Street, Moreno Valley  
 GROUND ELEVATION \_\_\_\_\_ HOLE SIZE 8 inches  
 GROUND WATER LEVELS:  
 AT TIME OF DRILLING ---  
 AT END OF DRILLING ---  
 AFTER DRILLING ---

DEPTH (ft)	GRAPHIC LOG	MATERIAL DESCRIPTION	SAMPLE TYPE NUMBER	RECOVERY % (RQD)	BLOW COUNTS (N VALUE)	POCKET PEN. (tsf)	DRY UNIT WT. (pcf)	MOISTURE CONTENT (%)	ATTERBERG LIMITS			FINES CONTENT (%)
									LIQUID LIMIT	PLASTIC LIMIT	PLASTICITY INDEX	
0												
		SILTY SAND (SM): yellowish brown, dry, ~70% sand, ~30% fines	MC R-1		45		107	4				
5		POORLY-GRADED SAND w. SILT & GRAVEL (SP-SM): brown, moist, ~15% fine gravel, ~75% medium sand, ~10% fines	MC R-2		38		109	6				
10			MC R-3		43		111	4				
15		POORLY-GRADED SAND (SP): yellowish light brown, moist, ~5% fines, ~95% sand	MC R-4		41		110	5				

Bottom of borehole at 16.5 feet below ground surface. Boring was backfilled with cuttings. No groundwater was encountered at the time of drilling.

Bottom of borehole at 16.5 feet.

GEOTECH BH COLUMNS - GINT STD US LAB.GDT - 12/7/17 22:11 - C:\PASSPORT\GIBI\76 GAS STATION\LOGS.GPJ

**CLIENT** Northwest Moreno Properties Inc  
**PROJECT NUMBER** Moreno Valley-1-01  
**DATE STARTED** 12/2/17 **COMPLETED** 12/2/17  
**DRILLING CONTRACTOR** GeoBoden, Inc.  
**DRILLING METHOD** HSA  
**LOGGED BY** C.R. **CHECKED BY** \_\_\_\_\_  
**NOTES** \_\_\_\_\_

**PROJECT NAME** Proposed 76 Gas Station  
**PROJECT LOCATION** Alessandro Boulevard/Laselle Street, Moreno Valley  
**GROUND ELEVATION** \_\_\_\_\_ **HOLE SIZE** 8 inches  
**GROUND WATER LEVELS:**  
**AT TIME OF DRILLING** ---  
**AT END OF DRILLING** ---  
**AFTER DRILLING** ---

DEPTH (ft)	GRAPHIC LOG	MATERIAL DESCRIPTION	SAMPLE TYPE NUMBER	RECOVERY % (RQD)	BLOW COUNTS (N VALUE)	POCKET PEN. (tsf)	DRY UNIT WT. (pcf)	MOISTURE CONTENT (%)	ATTERBERG LIMITS			FINES CONTENT (%)
									LIQUID LIMIT	PLASTIC LIMIT	PLASTICITY INDEX	
0												
5		SILTY SAND w. GRAVEL (SM): brown, moist, ~15% fine gravel, ~30% fines, ~55% medium to coarse sand	MC R-1		39							
10		SAND w. GRAVEL (SP): light brown, moist, ~15% fine to coarse gravel, ~80% fine sand, ~5% fines	MC R-2		43							
			MC R-3		46							

Bottom of borehole at 11.5 feet below ground surface. Boring was backfilled with cuttings. No groundwater was encountered at the time of drilling.

Bottom of borehole at 11.5 feet.

**CLIENT** Northwest Moreno Properties Inc  
**PROJECT NUMBER** Moreno Valley-1-01  
**DATE STARTED** 12/2/17 **COMPLETED** 12/2/17  
**DRILLING CONTRACTOR** GeoBoden, Inc.  
**DRILLING METHOD** HSA  
**LOGGED BY** C.R. **CHECKED BY** \_\_\_\_\_  
**NOTES** \_\_\_\_\_

**PROJECT NAME** Proposed 76 Gas Station  
**PROJECT LOCATION** Alessandro Boulevard/Laselle Street, Moreno Valley  
**GROUND ELEVATION** \_\_\_\_\_ **HOLE SIZE** 8 inches  
**GROUND WATER LEVELS:**  
**AT TIME OF DRILLING** ---  
**AT END OF DRILLING** ---  
**AFTER DRILLING** ---

DEPTH (ft)	GRAPHIC LOG	MATERIAL DESCRIPTION	SAMPLE TYPE NUMBER	RECOVERY % (RQD)	BLOW COUNTS (N VALUE)	POCKET PEN. (tsf)	DRY UNIT WT. (pcf)	MOISTURE CONTENT (%)	ATTERBERG LIMITS			FINES CONTENT (%)
									LIQUID LIMIT	PLASTIC LIMIT	PLASTICITY INDEX	
0												
		SAND w. GRAVEL (SP): light brown, moist, ~20% gravel	MC R-1		43							
5			MC R-2		45		108	2				
10			MC R-3		46							

Bottom of borehole at 11.5 feet below ground surface. Boring was backfilled with cuttings. No groundwater was encountered at the time of drilling.

Bottom of borehole at 11.5 feet.

**CLIENT** Northwest Moreno Properties Inc  
**PROJECT NUMBER** Moreno Valley-1-01  
**DATE STARTED** 12/2/17 **COMPLETED** 12/2/17  
**DRILLING CONTRACTOR** GeoBoden, Inc.  
**DRILLING METHOD** HSA  
**LOGGED BY** C.R. **CHECKED BY** \_\_\_\_\_  
**NOTES** \_\_\_\_\_

**PROJECT NAME** Proposed 76 Gas Station  
**PROJECT LOCATION** Alessandro Boulevard/Laselle Street, Moreno Valley  
**GROUND ELEVATION** \_\_\_\_\_ **HOLE SIZE** 8 inches  
**GROUND WATER LEVELS:**  
**AT TIME OF DRILLING** ---  
**AT END OF DRILLING** ---  
**AFTER DRILLING** ---

DEPTH (ft)	GRAPHIC LOG	MATERIAL DESCRIPTION	SAMPLE TYPE NUMBER	RECOVERY % (RQD)	BLOW COUNTS (N VALUE)	POCKET PEN. (tsf)	DRY UNIT WT. (pcf)	MOISTURE CONTENT (%)	ATTERBERG LIMITS			FINES CONTENT (%)
									LIQUID LIMIT	PLASTIC LIMIT	PLASTICITY INDEX	
0												
		SILTY SAND (SM): brown, dry, ~70% sand, ~30% fines	MC R-1		35							
5		POORLY-GRADED SAND w. SILT & GRAVEL (SP-SM): light brown, moist, ~15% gravel, ~10% fines, ~75% medium sand	MC R-2		41		109	4				
10			MC R-3		39							

Bottom of borehole at 11.5 feet below ground surface. Boring was backfilled with cuttings. No groundwater was encountered at the time of drilling.

Bottom of borehole at 11.5 feet.



**CLIENT** Northwest Moreno Properties Inc  
**PROJECT NUMBER** Moreno Valley-1-01  
**DATE STARTED** 12/2/17 **COMPLETED** 12/2/17  
**DRILLING CONTRACTOR** GeoBoden, Inc.  
**DRILLING METHOD** HSA  
**LOGGED BY** C.R. **CHECKED BY** \_\_\_\_\_  
**NOTES** \_\_\_\_\_

**PROJECT NAME** Proposed 76 Gas Station  
**PROJECT LOCATION** Alessandro Boulevard/Laselle Street, Moreno Valley  
**GROUND ELEVATION** \_\_\_\_\_ **HOLE SIZE** 8 inches  
**GROUND WATER LEVELS:**  
**AT TIME OF DRILLING** ---  
**AT END OF DRILLING** ---  
**AFTER DRILLING** ---

DEPTH (ft)	GRAPHIC LOG	MATERIAL DESCRIPTION	SAMPLE TYPE NUMBER	RECOVERY % (RQD)	BLOW COUNTS (N VALUE)	POCKET PEN. (tsf)	DRY UNIT WT. (pcf)	MOISTURE CONTENT (%)	ATTERBERG LIMITS			FINES CONTENT (%)
									LIQUID LIMIT	PLASTIC LIMIT	PLASTICITY INDEX	
0												
		SILTY SAND w. GRAVEL (SM): brown, moist, ~20% fines, ~75% sand, ~5% gravel	MC R-1		34							
5			MC R-2		41		115	2				
10			MC R-3		45							

Bottom of borehole at 11.5 feet below ground surface. Boring was backfilled with cuttings. No groundwater was encountered at the time of drilling.

Bottom of borehole at 11.5 feet.

## **APPENDIX C**

# **LABORATORY PROCEDURES AND TEST RESULTS**

## APPENDIX C

### Laboratory Procedures and Test Results

Laboratory testing provided quantitative and qualitative data involving the relevant engineering properties of the representative earth materials selected for testing. The representative samples were tested in general accordance with American Society for Testing and Materials (ASTM) procedures and/or California Test Methods (CTM).

**Soil Classification:** Earth materials encountered during exploration were classified and logged in general accordance with the Standard Practice for Description and Identification of Soils (Visual-Manual Procedure) of ASTM D 2488. Upon completion of laboratory testing, exploratory logs and sample descriptions were reconciled to reflect laboratory test results with regard to ASTM D 2487.

#### **Expansion Index:**

SAMPLE LOCATION	MATERIAL DESCRIPTION	EXPANSION INDEX	EXPANSION POTENTIAL
B-1 @ 0-5 feet	Silty SAND	10	Very Low

**Minimum Resistivity and pH Tests:** Minimum resistivity and pH Tests of select samples were performed using the guidelines of CTM 643. The test results are presented in the table below.

SAMPLE LOCATION	MATERIAL DESCRIPTION	pH	MINIMUM RESISTIVITY (ohm-cm)
B-1 @ 0-5 feet	Silty SAND	7.1	1769

**Soluble Sulfate:** The soluble sulfate content of select samples was determined using the guidelines of CTM 417. The test results are presented in the table below.

SAMPLE LOCATION	MATERIAL DESCRIPTION	SULFATE CONTENT (% by weight)	SULFATE EXPOSURE
B-1 @ 0-5 feet	Silty SAND	0.0119	Negligible

**Chloride Content:** Chloride content of select samples was determined using the guidelines of CTM 422. The test results are presented in the table below.

SAMPLE LOCATION	MATERIAL DESCRIPTION	CHLORIDE CONTENT (ppm)
B-1 @ 0-5 feet	Silty SAND	39

**APPENDIX D**  
**SEISMICITY**

# CALIFORNIA DEPARTMENT OF TRANSPORTATION

## Caltrans ARS Online (v2.3.09)

This web-based tool calculates both deterministic and probabilistic acceleration response spectra for any location in California based on criteria provided in [Appendix B of Caltrans Seismic Design Criteria](#). [More...](#)

### SELECT SITE LOCATION

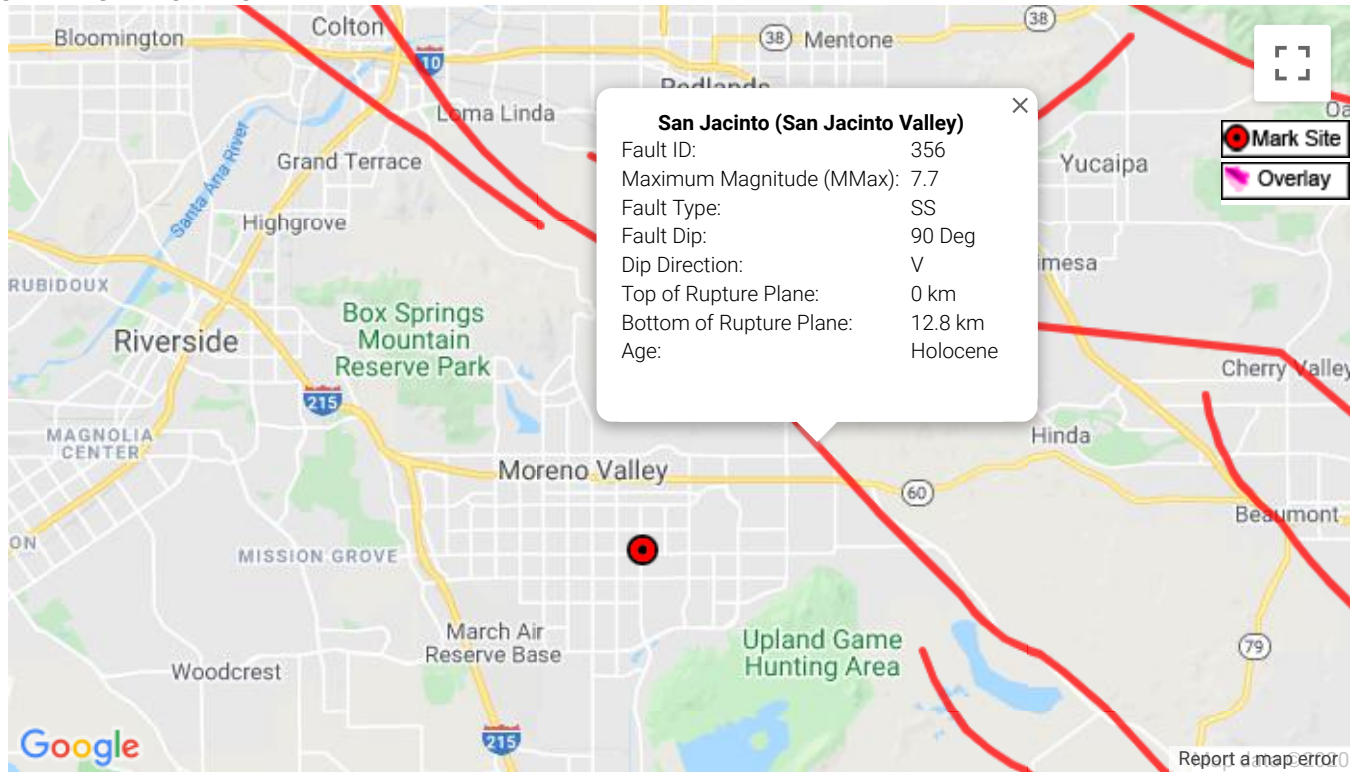

Latitude:  Longitude:  Vs30:  m/s

CALCULATED SPECTRA

Display Curves: 3

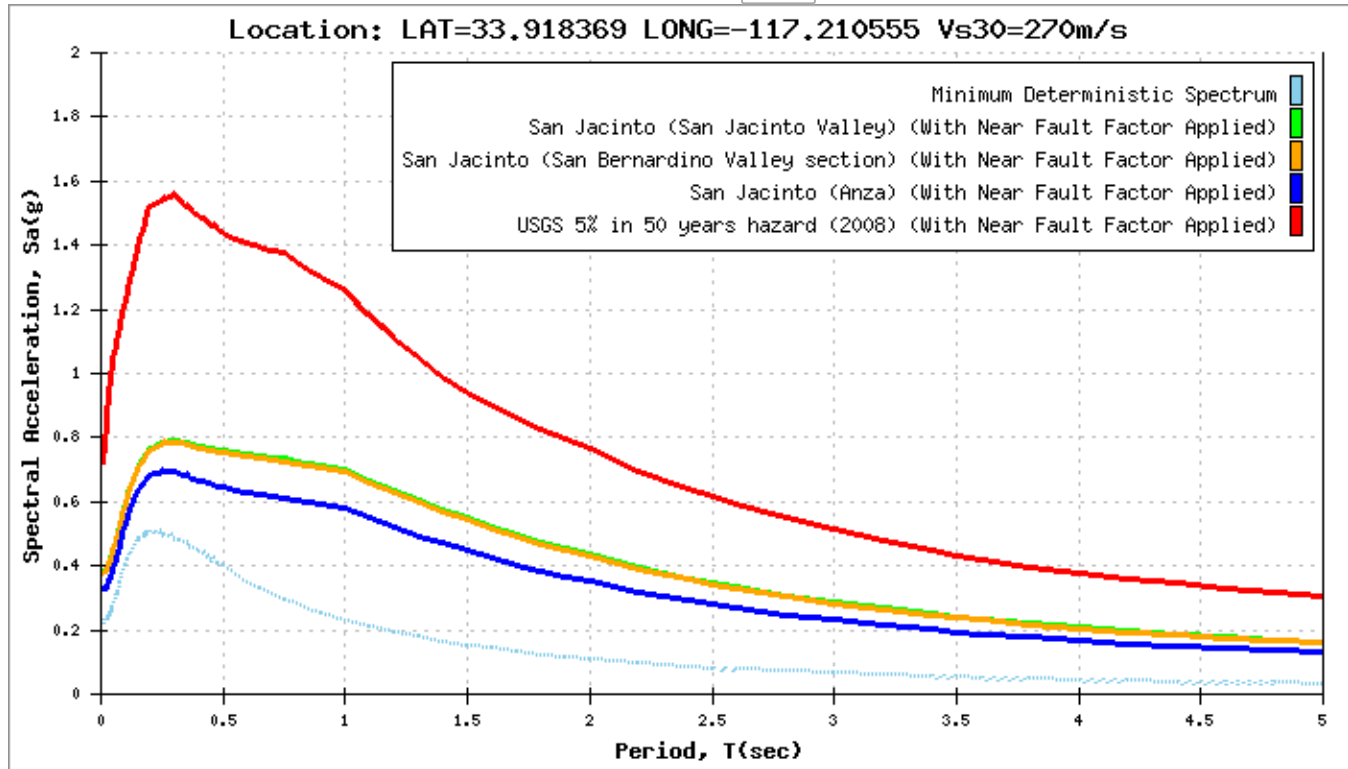

- Tabular Data
- Envelope Only
- Hide Near Fault
- Axis Scale
- Show Basin

Apply Near Fault Adjustment To:

NOTE: Caltrans SDC requires application of a Near Fault Adjustment factor for sites less than 25 km (Rrup) from the causative fault.

Deterministic Spectrum Using

- Km San Jacinto (San Jacinto Valley)
- Km San Jacinto (San Bernardino Valley section)
- Km San Jacinto (Anza)

Probabilistic Spectrum Using

Km (Recommend Performing Deaggregation To Verify)

- Show Spectrum with Adjustment Only
- Show Spectrum with and without near fault Adjustment

This application is being updated for digital accessibility and will continue to function while updates are in progress.

U.S. Geological Survey - Earthquake Hazards Program

# 2008 National Seismic Hazard Maps - Source Parameters

[New Search](#)

Distance in Miles	Name	State	Pref Slip Rate (mm/yr)	Dip (degrees)	Dip Dir	Slip Sense	Rupture Top (km)	Rupture Bottom (km)	Length (km)
3.99	<a href="#">San Jacinto;SJV</a>	CA	18	90	V	strike slip	0	16	43
3.99	<a href="#">San Jacinto;SBV+SJV+A+CC+B+SM</a>	CA	n/a	90	V	strike slip	0.1	15	241
3.99	<a href="#">San Jacinto;SBV+SJV+A+CC+B</a>	CA	n/a	90	V	strike slip	0.1	15	215
3.99	<a href="#">San Jacinto;SBV+SJV+A+CC</a>	CA	n/a	90	V	strike slip	0	16	181
3.99	<a href="#">San Jacinto;SBV+SJV+A+C</a>	CA	n/a	90	V	strike slip	0	17	181
3.99	<a href="#">San Jacinto;SBV+SJV+A</a>	CA	n/a	90	V	strike slip	0	16	134
3.99	<a href="#">San Jacinto;SBV+SJV</a>	CA	n/a	90	V	strike slip	0	16	88
3.99	<a href="#">San Jacinto;SJV+A+CC+B+SM</a>	CA	n/a	90	V	strike slip	0.1	15	196
3.99	<a href="#">San Jacinto;SJV+A+CC+B</a>	CA	n/a	90	V	strike slip	0.1	15	170
3.99	<a href="#">San Jacinto;SJV+A+CC</a>	CA	n/a	90	V	strike slip	0	16	136
3.99	<a href="#">San Jacinto;SJV+A+C</a>	CA	n/a	90	V	strike slip	0	17	136
3.99	<a href="#">San Jacinto;SJV+A</a>	CA	n/a	90	V	strike slip	0	17	89
6.13	<a href="#">San Jacinto;A+CC+B</a>	CA	n/a	90	V	strike slip	0.1	15	152
6.13	<a href="#">San Jacinto;A+CC</a>	CA	n/a	90	V	strike slip	0	16	118
6.13	<a href="#">San Jacinto;A+C</a>	CA	n/a	90	V	strike slip	0	17	118
6.13	<a href="#">San Jacinto;A</a>	CA	9	90	V	strike slip	0	17	71
6.13	<a href="#">San Jacinto;A+CC+B+SM</a>	CA	n/a	90	V	strike slip	0.1	15	178



6.98	<a href="#">San Jacinto;SBV</a>	CA	6	90	V	strike slip	0	16	45
14.31	<a href="#">S. San Andreas;NM+SM+NSB+SSB+BG+CO</a>	CA	n/a	84		strike slip	0.1	13	340
14.31	<a href="#">S. San Andreas;BB+NM+SM+NSB+SSB+BG+CO</a>	CA	n/a	85		strike slip	0.1	13	390
14.31	<a href="#">S. San Andreas;BB+NM+SM+NSB+SSB+BG</a>	CA	n/a	84		strike slip	0	14	321
14.31	<a href="#">S. San Andreas;BB+NM+SM+NSB+SSB</a>	CA	n/a	90	V	strike slip	0	14	263
14.31	<a href="#">S. San Andreas;SSB+BG+CO</a>	CA	n/a	77		strike slip	0.2	12	170
14.31	<a href="#">S. San Andreas;SSB</a>	CA	16	90	V	strike slip	0	13	43
14.31	<a href="#">S. San Andreas;SM+NSB+SSB+BG+CO</a>	CA	n/a	83		strike slip	0.1	13	303
14.31	<a href="#">S. San Andreas;SM+NSB+SSB+BG</a>	CA	n/a	81		strike slip	0	13	234
14.31	<a href="#">S. San Andreas;CH+CC+BB+NM+SM+NSB+SSB+BG+CO</a>	CA	n/a	86		strike slip	0.1	13	512
14.31	<a href="#">S. San Andreas;SSB+BG</a>	CA	n/a	71		strike slip	0	13	101
14.31	<a href="#">S. San Andreas;NSB+SSB+BG+CO</a>	CA	n/a	79		strike slip	0.2	12	206
14.31	<a href="#">S. San Andreas;SM+NSB+SSB</a>	CA	n/a	90	V	strike slip	0	13	176
14.31	<a href="#">S. San Andreas;PK+CH+CC+BB+NM+SM+NSB+SSB+BG+CO</a>	CA	n/a	86		strike slip	0.1	13	548
14.31	<a href="#">S. San Andreas;PK+CH+CC+BB+NM+SM+NSB+SSB+BG</a>	CA	n/a	86		strike slip	0.1	13	479
14.31	<a href="#">S. San Andreas;PK+CH+CC+BB+NM+SM+NSB+SSB</a>	CA	n/a	90	V	strike slip	0.1	13	421
14.31	<a href="#">S. San Andreas;CC+BB+NM+SM+NSB+SSB</a>	CA	n/a	90	V	strike slip	0	14	322
14.31	<a href="#">S. San Andreas;CC+BB+NM+SM+NSB+SSB+BG</a>	CA	n/a	85		strike slip	0	14	380
14.31	<a href="#">S. San Andreas;CC+BB+NM+SM+NSB+SSB+BG+CO</a>	CA	n/a	86		strike slip	0.1	13	449
14.31	<a href="#">S. San Andreas;CH+CC+BB+NM+SM+NSB+SSB</a>	CA	n/a	90	V	strike slip	0	14	384
14.31	<a href="#">S. San Andreas;CH+CC+BB+NM+SM+NSB+SSB+BG</a>	CA	n/a	86		strike slip	0	14	442
14.31	<a href="#">S. San Andreas;NSB+SSB+BG</a>	CA	n/a	75		strike	0	14	136

						slip			
14.31	<a href="#">S. San Andreas;NSB+SSB</a>	CA	n/a	90	V	strike slip	0	13	79
14.31	<a href="#">S. San Andreas;NM+SM+NSB+SSB</a>	CA	n/a	90	V	strike slip	0	13	213
14.31	<a href="#">S. San Andreas;NM+SM+NSB+SSB+BG</a>	CA	n/a	83		strike slip	0	14	271
15.99	<a href="#">S. San Andreas;NM+SM+NSB</a>	CA	n/a	90	V	strike slip	0	13	170
15.99	<a href="#">S. San Andreas;NSB</a>	CA	22	90	V	strike slip	0	13	35
15.99	<a href="#">S. San Andreas;CC+BB+NM+SM+NSB</a>	CA	n/a	90	V	strike slip	0	14	279
15.99	<a href="#">S. San Andreas;PK+CH+CC+BB+NM+SM+NSB</a>	CA	n/a	90	V	strike slip	0.1	13	377
15.99	<a href="#">S. San Andreas;CH+CC+BB+NM+SM+NSB</a>	CA	n/a	90	V	strike slip	0	14	341
15.99	<a href="#">S. San Andreas;SM+NSB</a>	CA	n/a	90	V	strike slip	0	13	133
15.99	<a href="#">S. San Andreas;BB+NM+SM+NSB</a>	CA	n/a	90	V	strike slip	0	14	220
18.45	<a href="#">Elsinore;GI+T+J</a>	CA	n/a	86	NE	strike slip	0	17	153
18.45	<a href="#">Elsinore;GI+T</a>	CA	5	90	V	strike slip	0	14	78
18.45	<a href="#">Elsinore;W+GI+T+J+CM</a>	CA	n/a	84	NE	strike slip	0	16	241
18.45	<a href="#">Elsinore;W+GI+T+J</a>	CA	n/a	84	NE	strike slip	0	16	199
18.45	<a href="#">Elsinore;W+GI+T</a>	CA	n/a	84	NE	strike slip	0	14	124
18.45	<a href="#">Elsinore;W+GI</a>	CA	n/a	81	NE	strike slip	0	14	83
18.45	<a href="#">Elsinore;GI</a>	CA	5	90	V	strike slip	0	13	37
18.45	<a href="#">Elsinore;GI+T+J+CM</a>	CA	n/a	86	NE	strike slip	0	16	195
20.12	<a href="#">Elsinore;T+J+CM</a>	CA	n/a	85	NE	strike slip	0	16	169
20.12	<a href="#">Elsinore;T</a>	CA	5	90	V	strike slip	0	14	52
20.12	<a href="#">Elsinore;T+J</a>	CA	n/a	86	NE	strike slip	0	17	127

21.47	<a href="#">Chino, alt 2</a>	CA	1	65	SW	strike slip	0	14	29
22.43	<a href="#">Cucamonga</a>	CA	5	45	N	thrust	0	8	28
22.72	<a href="#">Elsinore;W</a>	CA	2.5	75	NE	strike slip	0	14	46
22.73	<a href="#">Chino, alt 1</a>	CA	1	50	SW	strike slip	0	9	24
23.58	<a href="#">S. San Andreas;BG+CO</a>	CA	n/a	72		strike slip	0.3	12	125
23.58	<a href="#">S. San Andreas;BG</a>	CA	n/a	58		strike slip	0	13	56
24.70	<a href="#">Cleghorn</a>	CA	3	90	V	strike slip	0	16	25
27.69	<a href="#">North Frontal (West)</a>	CA	1	49	S	reverse	0	16	50
29.63	<a href="#">Pinto Mtn</a>	CA	2.5	90	V	strike slip	0	16	74
30.69	<a href="#">San Jose</a>	CA	0.5	74	NW	strike slip	0	15	20
33.55	<a href="#">Sierra Madre</a>	CA	2	53	N	reverse	0	14	57
33.55	<a href="#">Sierra Madre Connected</a>	CA	2	51		reverse	0	14	76
33.63	<a href="#">S. San Andreas;NM+SM</a>	CA	n/a	90	V	strike slip	0	14	134
33.63	<a href="#">S. San Andreas;SM</a>	CA	29	90	V	strike slip	0	13	98
33.63	<a href="#">S. San Andreas;BB+NM+SM</a>	CA	n/a	90	V	strike slip	0	14	184
33.63	<a href="#">S. San Andreas;CH+CC+BB+NM+SM</a>	CA	n/a	90	V	strike slip	0	14	306
33.63	<a href="#">S. San Andreas;CC+BB+NM+SM</a>	CA	n/a	90	V	strike slip	0	14	243
33.63	<a href="#">S. San Andreas;PK+CH+CC+BB+NM+SM</a>	CA	n/a	90	V	strike slip	0.1	13	342
34.71	<a href="#">San Joaquin Hills</a>	CA	0.5	23	SW	thrust	2	13	27
36.01	<a href="#">Helendale-So Lockhart</a>	CA	0.6	90	V	strike slip	0	13	114
37.21	<a href="#">North Frontal (East)</a>	CA	0.5	41	S	thrust	0	16	27
37.82	<a href="#">Puente Hills (Coyote Hills)</a>	CA	0.7	26	N	thrust	2.8	15	17
41.46	<a href="#">Elsinore;J</a>	CA	3	84	NE	strike slip	0	19	75
41.46	<a href="#">Elsinore;J+CM</a>	CA	3	84	NE	strike	0	17	118

						slip			
42.70	<a href="#">Clamshell-Sawpit</a>	CA	0.5	50	NW	reverse	0	14	16
44.04	<a href="#">Lenwood-Lockhart-Old Woman Springs</a>	CA	0.9	90	V	strike slip	0	13	145
44.16	<a href="#">Newport-Inglewood (Offshore)</a>	CA	1.5	90	V	strike slip	0	10	66
44.16	<a href="#">Newport Inglewood Connected alt 1</a>	CA	1.3	89		strike slip	0	11	208
44.16	<a href="#">Newport Inglewood Connected alt 2</a>	CA	1.3	90	V	strike slip	0	11	208
46.44	<a href="#">Puente Hills (Santa Fe Springs)</a>	CA	0.7	29	N	thrust	2.8	15	11
46.71	<a href="#">Newport-Inglewood, alt 1</a>	CA	1	88		strike slip	0	15	65
46.80	<a href="#">Burnt Mtn</a>	CA	0.6	67	W	strike slip	0	16	21
47.85	<a href="#">Raymond</a>	CA	1.5	79	N	strike slip	0	16	22
48.30	<a href="#">Landers</a>	CA	0.6	90	V	strike slip	0	15	95
48.85	<a href="#">Eureka Peak</a>	CA	0.6	90	V	strike slip	0	15	19
49.34	<a href="#">San Jacinto;CC+B</a>	CA	n/a	90	V	strike slip	0.2	14	77
49.34	<a href="#">San Jacinto;CC</a>	CA	4	90	V	strike slip	0	16	43
49.34	<a href="#">San Jacinto;CC+B+SM</a>	CA	n/a	90	V	strike slip	0.2	14	103
49.82	<a href="#">San Jacinto;C</a>	CA	14	90	V	strike slip	0	17	47
50.28	<a href="#">Johnson Valley (No)</a>	CA	0.6	90	V	strike slip	0	16	35
52.14	<a href="#">Elysian Park (Upper)</a>	CA	1.3	50	NE	reverse	3	15	20
52.75	<a href="#">Puente Hills (LA)</a>	CA	0.7	27	N	thrust	2.1	15	22
56.12	<a href="#">Verdugo</a>	CA	0.5	55	NE	reverse	0	15	29
56.12	<a href="#">S. San Andreas;CO</a>	CA	20	90	V	strike slip	0.6	11	69
56.21	<a href="#">Rose Canyon</a>	CA	1.5	90	V	strike slip	0	8	70
56.61	<a href="#">So Emerson-Copper Mtn</a>	CA	0.6	90	V	strike slip	0	14	54
58.34	<a href="#">Palos Verdes Connected</a>	CA	3	90	V	strike	0	10	285

							slip		
58.34	<a href="#">Palos Verdes</a>	CA	3	90	V	strike slip	0	14	99
60.00	<a href="#">Coronado Bank</a>	CA	3	90	V	strike slip	0	9	186
60.18	<a href="#">Hollywood</a>	CA	1	70	N	strike slip	0	17	17
62.06	<a href="#">Calico-Hidalgo</a>	CA	1.8	90	V	strike slip	0	14	117
62.30	<a href="#">Earthquake Valley</a>	CA	2	90	V	strike slip	0	19	20
63.05	<a href="#">Santa Monica Connected alt 2</a>	CA	2.4	44		strike slip	0.8	11	93
66.77	<a href="#">Pisgah-Bullion Mtn-Mesquite Lk</a>	CA	0.8	90	V	strike slip	0	13	88
67.00	<a href="#">Sierra Madre (San Fernando)</a>	CA	2	45	N	thrust	0	13	18
67.26	<a href="#">San Gabriel</a>	CA	1	61	N	strike slip	0	15	71
67.84	<a href="#">Gravel Hills-Harper Lk</a>	CA	0.7	90	V	strike slip	0	11	65
69.79	<a href="#">Santa Monica, alt 1</a>	CA	1	75	N	strike slip	0	18	14
69.79	<a href="#">Santa Monica Connected alt 1</a>	CA	2.6	51		strike slip	0	16	79
72.21	<a href="#">Northridge</a>	CA	1.5	35	S	thrust	7.4	17	33
75.91	<a href="#">Malibu Coast, alt 1</a>	CA	0.3	75	N	strike slip	0	8	38
75.91	<a href="#">Malibu Coast, alt 2</a>	CA	0.3	74	N	strike slip	0	16	38
75.93	<a href="#">San Jacinto:B</a>	CA	4	90	V	strike slip	0.7	13	34
75.93	<a href="#">San Jacinto:B+SM</a>	CA	n/a	90	V	strike slip	0.4	12	61
76.18	<a href="#">Blackwater</a>	CA	0.5	90	V	strike slip	0	12	60
77.41	<a href="#">Anacapa-Dume, alt 2</a>	CA	3	41	N	thrust	1.2	12	65
78.84	<a href="#">Santa Susana, alt 1</a>	CA	5	55	N	reverse	0	16	27
82.29	<a href="#">Elsinore;CM</a>	CA	3	82	NE	strike slip	0	13	39
84.05	<a href="#">Holser, alt 1</a>	CA	0.4	58	S	reverse	0	19	20
85.43	<a href="#">Anacapa-Dume, alt 1</a>	CA	3	45	N	thrust	0	16	51

89.26	<a href="#">Simi-Santa Rosa</a>	CA	1	60		strike slip	1	12	39
91.73	<a href="#">S. San Andreas;BB+NM</a>	CA	n/a	90	V	strike slip	0	15	87
91.73	<a href="#">S. San Andreas;NM</a>	CA	27	90	V	strike slip	0	15	37
91.73	<a href="#">S. San Andreas;CH+CC+BB+NM</a>	CA	n/a	90	V	strike slip	0	14	208
91.73	<a href="#">S. San Andreas;PK+CH+CC+BB+NM</a>	CA	n/a	90	V	strike slip	0.1	12	245
91.73	<a href="#">S. San Andreas;CC+BB+NM</a>	CA	n/a	90	V	strike slip	0	15	146
92.78	<a href="#">Oak Ridge (Onshore)</a>	CA	4	65	S	reverse	1	19	49
92.78	<a href="#">Oak Ridge Connected</a>	CA	3.6	53		reverse	0.6	15	94
95.82	<a href="#">San Cayetano</a>	CA	6	42	N	thrust	0	16	42
96.69	<a href="#">San Jacinto;SM</a>	CA	n/a	90	V	strike slip	0	12	26
97.34	<a href="#">Superstition Hills</a>	CA	4	90	V	strike slip	0.6	12	36
99.38	<a href="#">Elmore Ranch</a>	CA	1	90	V	strike slip	0	11	29



## Search Results

12 of 12 earthquakes in map area.

▼ Click for more information

<b>6.3</b>	<b>7km SSE of Big Bear City, CA</b> 1992-06-28 15:05:30 (UTC)	3.6 km
<b>7.3</b>	<b>Landers, California Earthquake</b> 1992-06-28 11:57:34 (UTC)	-0.1 km
<b>6.1</b>	<b>17km NNE of Thousand Palms, California</b> 1992-04-23 04:50:23 (UTC)	11.6 km
<b>6.0</b>	<b>6km SSW of Morongo Valley, CA</b> 1986-07-08 09:20:44 (UTC)	9.5 km
<b>6.0</b>	<b>16km E of Desert Hot Springs, CA</b> 1948-12-04 23:43:16 (UTC)	6.0 km
<b>6.4</b>	<b>Long Beach, California Earthquake</b> 1933-03-11 01:54:09 (UTC)	6.0 km
<b>6.8</b>	<b>Southern California</b> 1918-04-21 22:32:25 (UTC)	-
<b>6.8</b>	<b>Southern California</b> 1899-12-25 12:25:00 (UTC)	-
<b>6.4</b>	<b>Southern California</b> 1899-07-22 20:32:00 (UTC)	-
<b>6.0</b>	<b>Near San Bernardino, California</b> 1858-12-16 10:00:00 (UTC)	-
<b>6.0</b>	<b>Greater Los Angeles area, California</b> 1855-07-11 04:15:00 (UTC)	-
<b>6.9</b>	<b>Southern California</b> 1812-12-08 15:00:00 (UTC)	-

### Didn't find what you were looking for?

- Check your [Settings](#).
- [Which earthquakes are included on the map and list?](#)
- [Felt something not shown – report it here.](#)



Latitude, Longitude: 33.918369, -117.210555

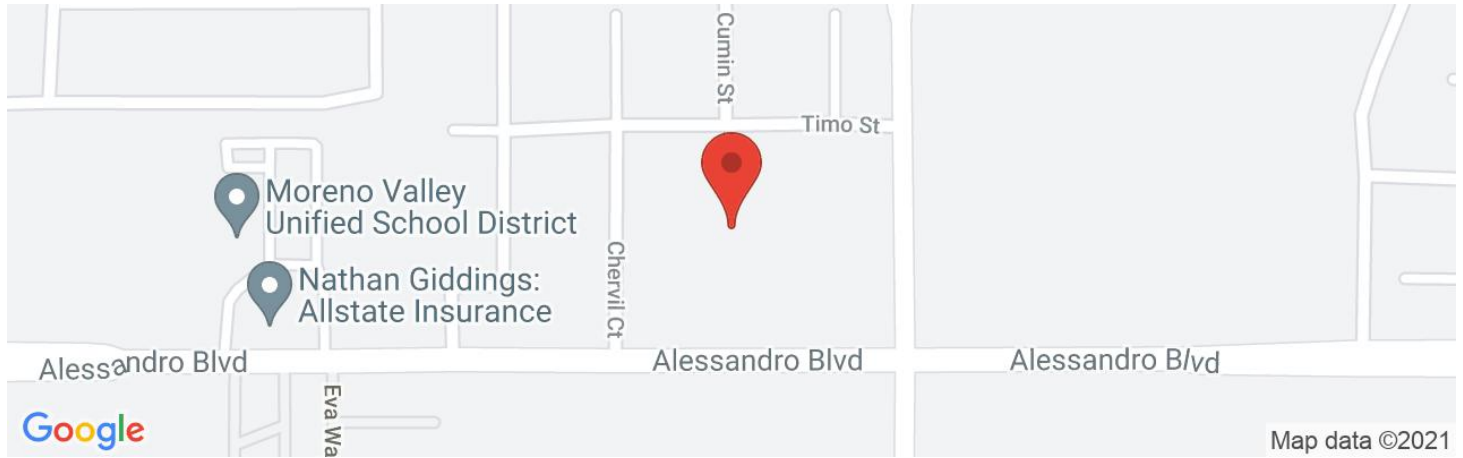

<b>Date</b>	9/8/2021, 7:43:35 AM
<b>Design Code Reference Document</b>	ASCE7-16
<b>Risk Category</b>	II
<b>Site Class</b>	D - Default (See Section 11.4.3)

Type	Value	Description
$S_S$	1.728	$MCE_R$ ground motion. (for 0.2 second period)
$S_1$	0.675	$MCE_R$ ground motion. (for 1.0s period)
$S_{MS}$	2.074	Site-modified spectral acceleration value
$S_{M1}$	null -See Section 11.4.8	Site-modified spectral acceleration value
$S_{DS}$	1.382	Numeric seismic design value at 0.2 second SA
$S_{D1}$	null -See Section 11.4.8	Numeric seismic design value at 1.0 second SA

Type	Value	Description
SDC	null -See Section 11.4.8	Seismic design category
$F_a$	1.2	Site amplification factor at 0.2 second
$F_v$	null -See Section 11.4.8	Site amplification factor at 1.0 second
PGA	0.731	$MCE_G$ peak ground acceleration
$F_{PGA}$	1.2	Site amplification factor at PGA
$PGA_M$	0.877	Site modified peak ground acceleration
$T_L$	8	Long-period transition period in seconds
$S_{sRT}$	1.889	Probabilistic risk-targeted ground motion. (0.2 second)
$S_{sUH}$	2.061	Factored uniform-hazard (2% probability of exceedance in 50 years) spectral acceleration
$S_{sD}$	1.728	Factored deterministic acceleration value. (0.2 second)
$S_{1RT}$	0.737	Probabilistic risk-targeted ground motion. (1.0 second)
$S_{1UH}$	0.823	Factored uniform-hazard (2% probability of exceedance in 50 years) spectral acceleration.
$S_{1D}$	0.675	Factored deterministic acceleration value. (1.0 second)
$PGAd$	0.731	Factored deterministic acceleration value. (Peak Ground Acceleration)
$C_{RS}$	0.916	Mapped value of the risk coefficient at short periods
$C_{R1}$	0.895	Mapped value of the risk coefficient at a period of 1 s



## DISCLAIMER

While the information presented on this website is believed to be correct, SEAOC / OSHPD and its sponsors and contributors assume no responsibility or liability for its accuracy. The material presented in this web application should not be used or relied upon for any specific application without competent examination and verification of its accuracy, suitability and applicability by engineers or other licensed professionals. SEAO C / OSHP D do not intend that the use of this information replace the sound judgment of such competent professionals, having experience and knowledge in the field of practice, nor to substitute for the standard of care required of such professionals in interpreting and applying the results of the seismic data provided by this website. Users of the information from this website assume all liability arising from such use. Use of the output of this website does not imply approval by the governing building code bodies responsible for building code approval and interpretation for the building site described by latitude/longitude location in the search results of this website.

**APPENDIX E**  
**GENERAL EARTHWORK AND GRADING**  
**SPECIFICATIONS**

## EARTH-STRATA

### General Earthwork and Grading Specifications

#### General

**Intent:** These General Earthwork and Grading Specifications are intended to be the minimum requirements for the grading and earthwork shown on the approved grading plan(s) and/or indicated in the geotechnical report(s). These General Earthwork and Grading Specifications should be considered a part of the recommendations contained in the geotechnical report(s) and if they are in conflict with the geotechnical report(s), the specific recommendations in the geotechnical report shall supersede these more general specifications. Observations made during earthwork operations by the project Geotechnical Consultant may result in new or revised recommendations that may supersede these specifications and/or the recommendations in the geotechnical report(s).

**The Geotechnical Consultant of Record:** The Owner shall employ a qualified Geotechnical Consultant of Record (Geotechnical Consultant), prior to commencement of grading or construction. The Geotechnical Consultant shall be responsible for reviewing the approved geotechnical report(s) and accepting the adequacy of the preliminary geotechnical findings, conclusions, and recommendations prior to the commencement of the grading or construction.

Prior to commencement of grading or construction, the Owner shall coordinate with the Geotechnical Consultant, and Earthwork Contractor (Contractor) to schedule sufficient personnel for the appropriate level of observation, mapping, and compaction testing.

During earthwork and grading operations, the Geotechnical Consultant shall observe, map, and document the subsurface conditions to confirm assumptions made during the geotechnical design phase of the project. Should the observed conditions differ significantly from the interpretive assumptions made during the design phase, the Geotechnical Consultant shall recommend appropriate changes to accommodate the observed conditions, and notify the reviewing agency where required.

The Geotechnical Consultant shall observe the moisture conditioning and processing of the excavations and fill materials. The Geotechnical Consultant should perform periodic relative density testing of fill materials to verify that the attained level of compaction is being accomplished as specified.

**The Earthwork Contractor:** The Earthwork Contractor (Contractor) shall be qualified, experienced, and knowledgeable in earthwork logistics, preparation and processing of earth materials to receive compacted fill, moisture-conditioning and processing of fill, and compacting fill. The Contractor shall be provided with the approved grading plans and geotechnical report(s) for his review and acceptance of responsibilities, prior to commencement of grading. The Contractor shall be solely responsible for performing the grading in accordance with the approved grading plans and geotechnical report(s). Prior to commencement of grading, the Contractor shall prepare and submit to the Owner and the Geotechnical Consultant a work plan that indicates the sequence of earthwork grading, the number of "equipment" of work and the estimated quantities of daily earthwork contemplated for the site. The Contractor shall inform the Owner and the Geotechnical Consultant of work schedule changes and revisions to the work plan at least 24 hours in advance of such changes so that appropriate personnel will be available for observation and testing. No assumptions shall be made by the Contractor with regard to whether the Geotechnical Consultant is aware of all grading operations.

It is the sole responsibility of the Contractor to provide adequate equipment and methods to accomplish the earthwork operations in accordance with the applicable grading codes and agency ordinances, these specifications, and the recommendations in the approved geotechnical report(s) and grading plan(s). At the sole discretion of the Geotechnical Consultant, any unsatisfactory conditions, such as unsuitable earth materials, improper moisture conditioning, inadequate compaction, insufficient buttress keyway size, adverse weather conditions, etc., resulting in a quality of work less than required in the approved grading plans and geotechnical report(s), the Geotechnical Consultant shall reject the work and may recommend to the Owner that grading be stopped until conditions are corrected.

### **Preparation of Areas for Compacted Fill**

**Clearing and Grubbing:** Vegetation, such as brush, grass, roots, and other deleterious material shall be sufficiently removed and properly disposed in a method acceptable to the Owner, Geotechnical Consultant, and governing agencies.

The Geotechnical Consultant shall evaluate the extent of these removals on a site by site basis. Earth materials to be placed as compacted fill shall not contain more than 1 percent organic materials (by volume). No compacted fill lift shall contain more than 10 percent organic matter.

Should potentially hazardous materials be encountered, the Contractor shall stop work in the affected area, and a hazardous materials specialist shall immediately be consulted to evaluate the potentially hazardous materials, prior to continuing to work in that area.

It is our understanding that the State of California defines most refined petroleum products (gasoline, diesel fuel, motor oil, grease, coolant, etc.) as hazardous waste. As such, indiscriminate dumping or spillage of these fluids may constitute a misdemeanor, punishable by fines and/or imprisonment, and shall be prohibited. The contractor is responsible for all hazardous waste related to his operations. The Geotechnical Consultant does not have expertise in this area. If hazardous waste is a concern, then the Owner should contract the services of a qualified environmental assessor.

**Processing:** Exposed earth materials that have been observed to be satisfactory for support of compacted fill by the Geotechnical Consultant shall be scarified to a minimum depth of 6 inches. Exposed earth materials that are not observed to be satisfactory shall be removed or alternative recommendations may be provided by the Geotechnical Consultant. Scarification shall continue until the exposed earth materials are broken down and free of oversize material and the working surface is reasonably uniform, flat, and free of uneven features that would inhibit uniform compaction. The earth materials should be moistened or air dried to near optimum moisture content, prior to compaction.

**Overexcavation:** The Cut Lot Typical Detail and Cut/Fill Transition Lot Typical Detail, included herein provides a graphic illustration that depicts typical overexcavation recommendations made in the approved geotechnical report(s) and/or grading plan(s).

**Keyways and Benching:** Where fills are to be placed on slopes steeper than 5:1 (horizontal to vertical units), the ground shall be thoroughly benched as compacted fill is placed. Please see the three Keyway and Benching Typical Details with subtitles Cut Over Fill Slope, Fill Over Cut Slope, and Fill Slope for a graphic illustration. The lowest bench or smallest keyway shall be a minimum of 10 feet wide (or ½ the proposed slope height) and at least 2 feet into competent earth materials as advised by the Geotechnical Consultant. Typical benches shall be excavated a minimum height of 4 feet into competent earth materials or as recommended by the Geotechnical Consultant. Fill placed on slopes steeper than 5:1 should be thoroughly benched or otherwise excavated to provide a flat subgrade for the compacted fill.

**Evaluation/Acceptance of Bottom Excavations:** All areas to receive compacted fill (bottom excavations), including removal excavations, processed areas, keyways, and benching, shall be observed, mapped, general elevations recorded, and/or tested prior to being accepted by the Geotechnical Consultant as suitable to receive compacted fill. The Contractor shall obtain a written acceptance from the Geotechnical Consultant prior to placing compacted fill. A licensed surveyor shall provide the survey control for determining elevations of bottom excavations, processed areas, keyways, and

benching. The Geotechnical Consultant is not responsible for erroneously located, fills, subdrain systems, or excavations.

## **Fill Materials**

**General:** Earth material to be used as compacted fill should to a large extent be free of organic matter and other deleterious substances as evaluated and accepted by the Geotechnical Consultant.

**Oversize:** Oversize material is rock that does not break down into smaller pieces and has a maximum diameter greater than 12 inches. Oversize rock shall not be included within compacted fill unless specific methods and guidelines acceptable to the Geotechnical Consultant are followed. For examples of methods and guidelines of oversize rock placement see the enclosed Oversize Rock Disposal Detail. The inclusion of oversize materials in the compacted fill shall only be acceptable if the oversize material is completely surrounded by compacted fill or thoroughly jetted granular materials. No oversize material shall be placed within 10 vertical feet of finish grade or within 2 feet of proposed utilities or underground improvements.

**Import:** Should imported earth materials be required, the proposed import materials shall meet the requirements of the Geotechnical Consultant. Well graded, very low expansion potential earth materials free of organic matter and other deleterious substances are usually sought after as import materials. However, it is generally in the Owners best interest that potential import earth materials are provided to the Geotechnical Consultant to determine their suitability for the intended purpose. At least 48 hours should be allotted for the appropriate laboratory testing to be performed, prior to starting the import operations.

## **Fill Placement and Compaction Procedures**

**Fill Layers:** Fill materials shall be placed in areas prepared to receive fill in nearly horizontal layers not exceeding 8 inches in loose thickness. Thicker layers may be accepted by the Geotechnical Consultant, provided field density testing indicates that the grading procedures can adequately compact the thicker layers. Each layer of fill shall be spread evenly and thoroughly mixed to obtain uniformity within the earth materials and consistent moisture throughout the fill.

**Moisture Conditioning of Fill:** Earth materials to be placed as compacted fill shall be watered, dried, blended, and/or mixed, as needed to obtain relatively uniform moisture contents that are at or slightly above optimum. The maximum density and optimum moisture content tests should be performed in accordance with the American Society of Testing and Materials (ASTM test method D1557-00).

**Compaction of Fill:** After each layer has been moisture-conditioned, mixed, and evenly spread, it should be uniformly compacted to a minimum of 90 percent of maximum dry density as determined by ASTM test method D1557-00. Compaction equipment shall be adequately sized and be either specifically designed for compaction of earth materials or be proven to consistently achieve the required level of compaction.

**Compaction of Fill Slopes:** In addition to normal compaction procedures specified above, additional effort to obtain compaction on slopes is needed. This may be accomplished by backrolling of slopes with sheepsfoot rollers as the fill is being placed, by overbuilding the fill slopes, or by other methods producing results that are satisfactory to the Geotechnical Consultant. Upon completion of grading, relative compaction of the fill and the slope face shall be a minimum of 90 percent of maximum density per ASTM test method D1557-00.

**Compaction Testing of Fill:** Field tests for moisture content and relative density of the compacted fill earth materials shall be periodically performed by the Geotechnical Consultant. The location and frequency of tests shall be at the Geotechnical Consultant's discretion based on field observations. Compaction test locations will not necessarily be random. The test locations may or may not be selected to verify minimum compaction requirements in areas that are typically prone to inadequate compaction, such as close to slope faces and near benching.

**Frequency of Compaction Testing:** Compaction tests shall be taken at minimum intervals of every 2 vertical feet and/or per 1,000 cubic yards of compacted materials placed. Additionally, as a guideline, at least one (1) test shall be taken on slope faces for each 5,000 square feet of slope face and/or for each 10 vertical feet of slope. The Contractor shall assure that fill placement is such that the testing schedule described herein can be accomplished by the Geotechnical Consultant. The Contractor shall stop or slow down the earthwork operations to a safe level so that these minimum standards can be obtained.

**Compaction Test Locations:** The approximate elevation and horizontal coordinates of each test location shall be documented by the Geotechnical Consultant. The Contractor shall coordinate with the Surveyor to assure that sufficient grade stakes are established. This will provide the Geotechnical Consultant with sufficient accuracy to determine the approximate test locations and elevations. The Geotechnical Consultant can not be responsible for staking erroneously located by the Surveyor or Contractor. A minimum of two grade stakes should be provided at a maximum horizontal distance of 100 feet and vertical difference of less than 5 feet.

## **Subdrain System Installation**

Subdrain systems shall be installed in accordance with the approved geotechnical report(s), the approved grading plan, and the typical details provided herein. The Geotechnical Consultant may recommend additional subdrain systems and/or changes to the subdrain systems described herein, with regard to the extent, location, grade, or material depending on conditions encountered during grading or other factors. All subdrain systems shall be surveyed by a licensed land surveyor (except for retaining wall subdrain systems) to verify line and grade after installation and prior to burial. Adequate time should be allowed by the Contractor to complete these surveys.

## **Excavation**

All excavations and over-excavations for remedial purposes shall be evaluated by the Geotechnical Consultant during grading operations. Remedial removal depths indicated on the geotechnical plans are estimates only. The actual removal depths and extent shall be determined by the Geotechnical Consultant based on the field evaluation of exposed conditions during grading operations. Where fill over cut slopes are planned, the cut portion of the slope shall be excavated, evaluated, and accepted by the Geotechnical Consultant prior to placement of the fill portion of the proposed slope, unless specifically addressed by the Geotechnical Consultant. Typical details for cut over fill slopes and fill over cut slopes are provided herein.

## **Trench Backfill**

- 1) The Contractor shall follow all OSHA and Cal/OSHA requirements for trench excavation safety.
- 2) Bedding and backfill of utility trenches shall be done in accordance with the applicable provisions in the Standard Specifications of Public Works Construction. Bedding materials shall have a Sand Equivalency more than 30 (SE>30). The bedding shall be placed to 1 foot over the conduit and thoroughly jetting to provide densification. Backfill should be compacted to a minimum of 90 percent of maximum dry density, from 1 foot above the top of the conduit to the surface.
- 3) Jetting of the bedding materials around the conduits shall be observed by the Geotechnical Consultant.
- 4) The Geotechnical Consultant shall test trench backfill for the minimum compaction requirements recommended herein. At least one test should be conducted for every 300 linear feet of trench and for each 2 vertical feet of backfill.
- 5) For trench backfill the lift thicknesses shall not exceed those allowed in the Standard Specifications of Public Works Construction, unless the Contractor can demonstrate to the Geotechnical Consultant that the fill lift can be compacted to the minimum relative compaction by his alternative equipment or method.



# STABILIZATION FILL TYPICAL DETAIL

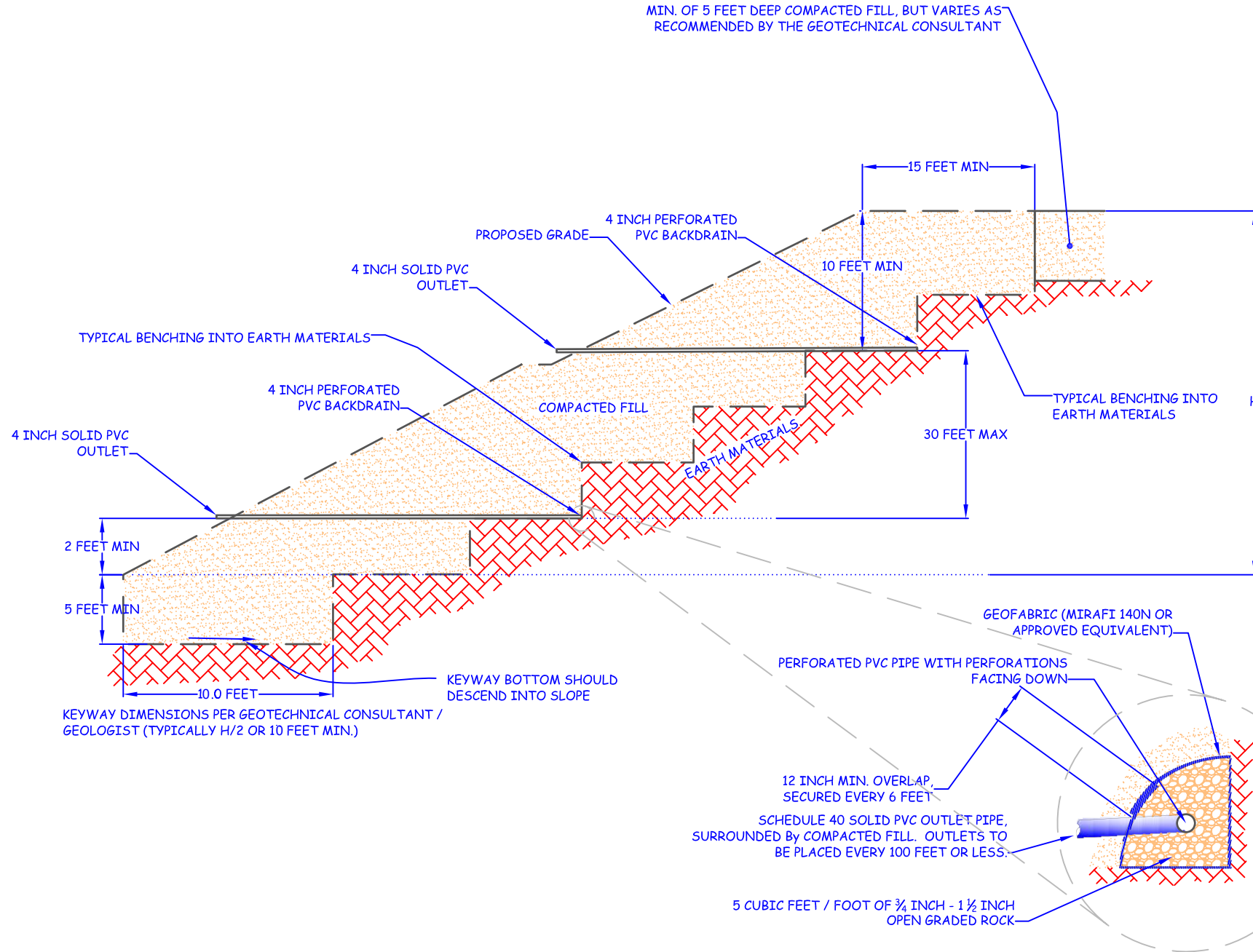

# BUTTRESS TYPICAL DETAIL

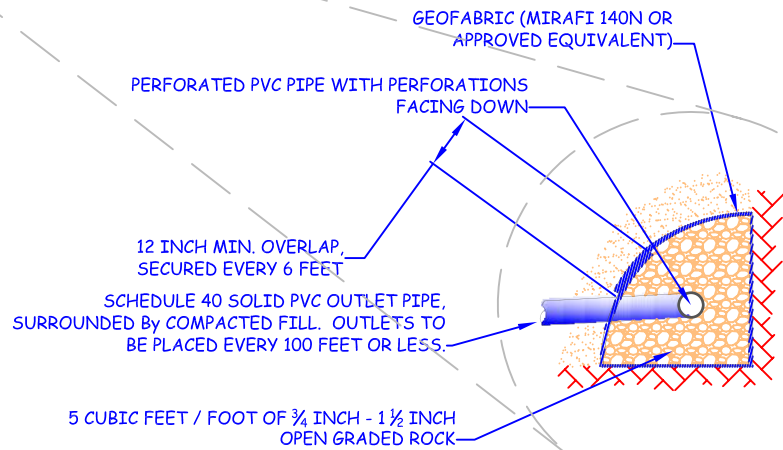
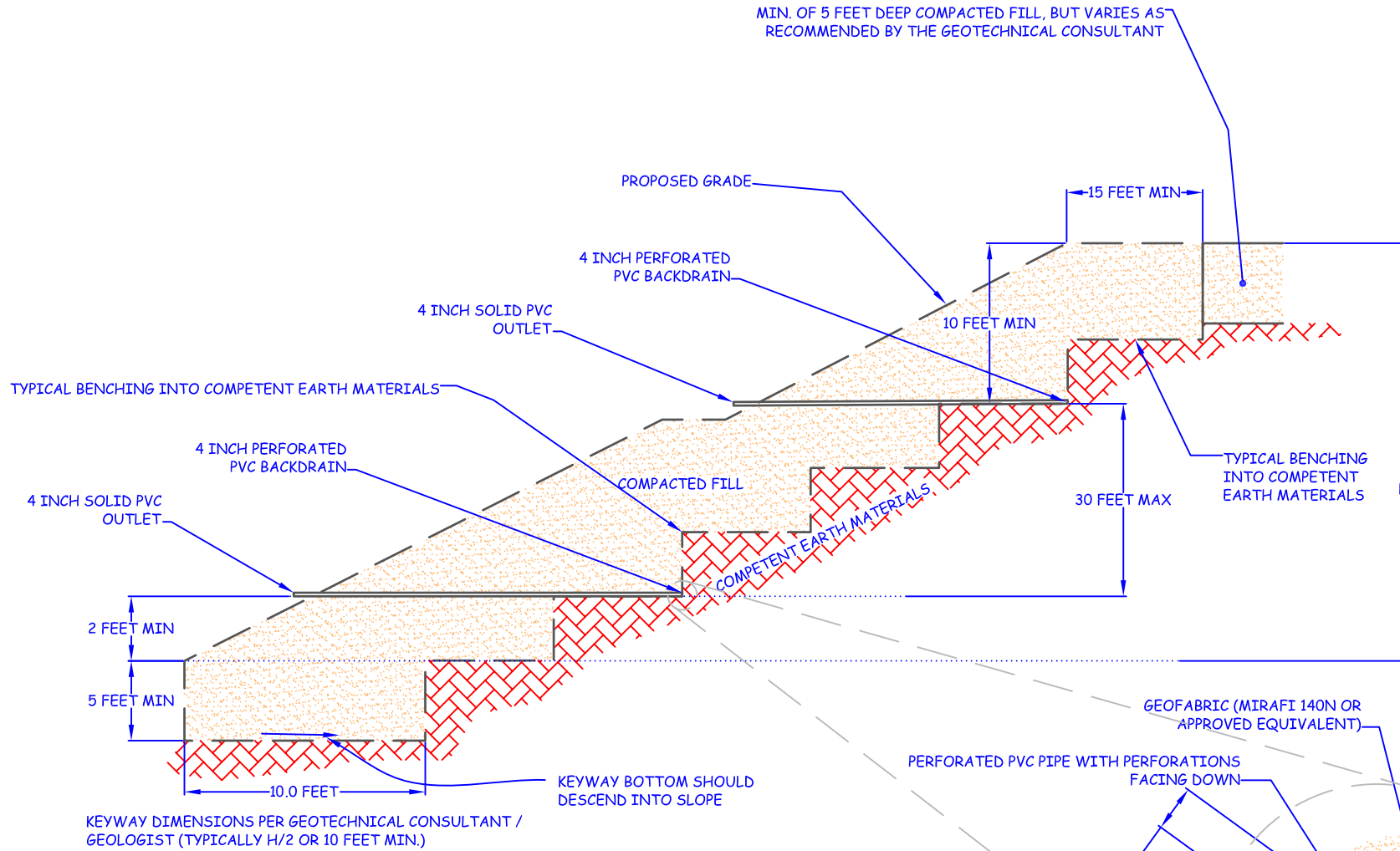

# CANYON SUBDRAIN SYSTEM TYPICAL DETAIL

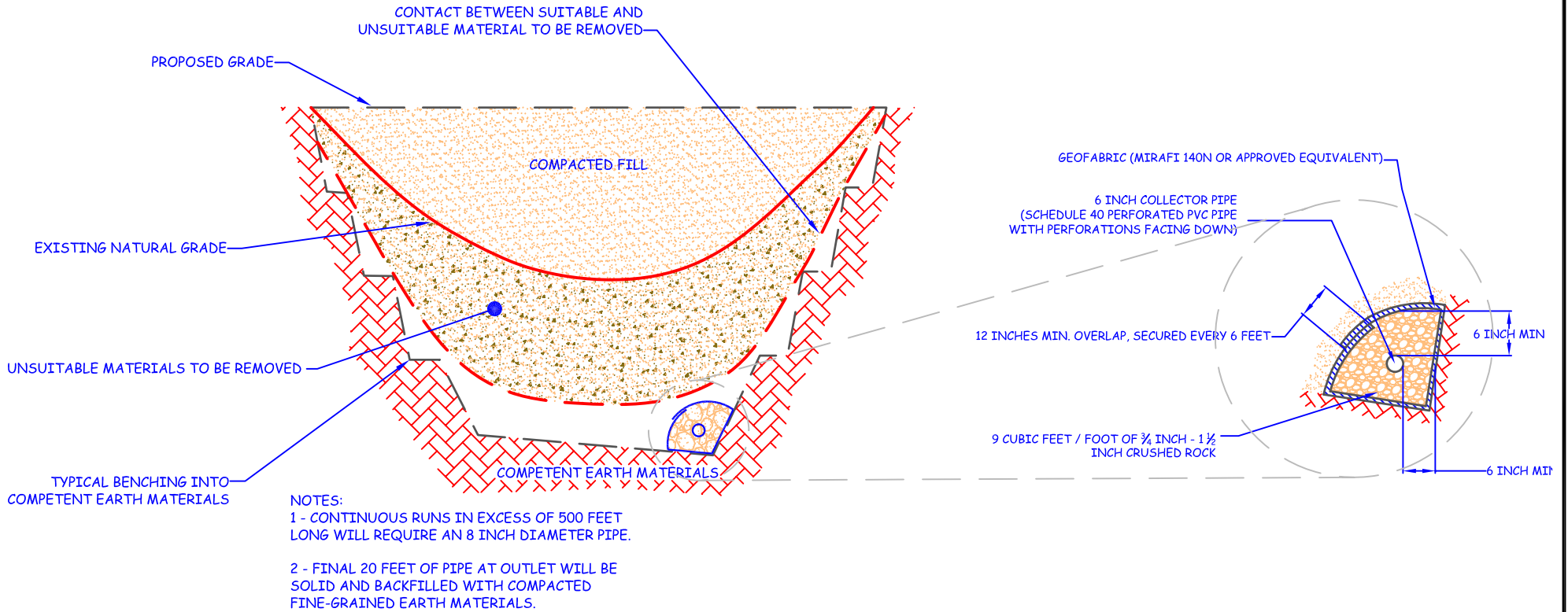

## CANYON SUBDRAIN TYPICAL OUTLET

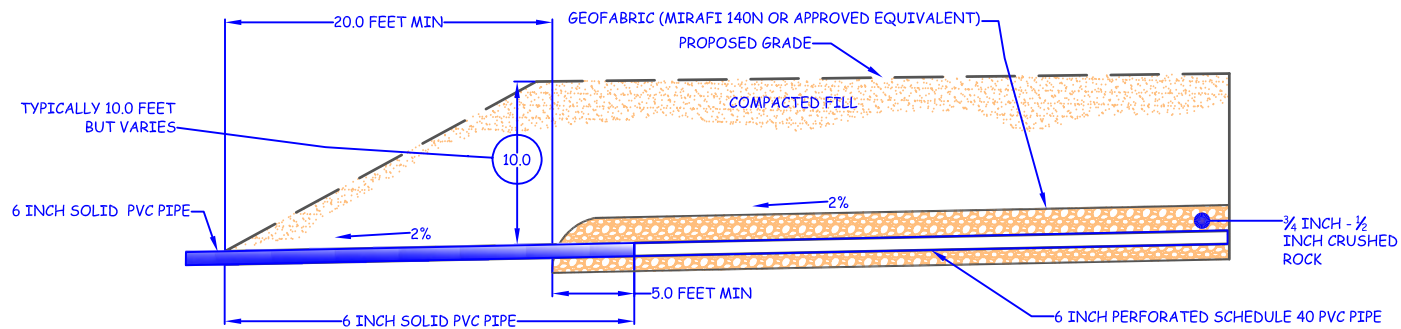

## CUT LOT TYPICAL DETAIL

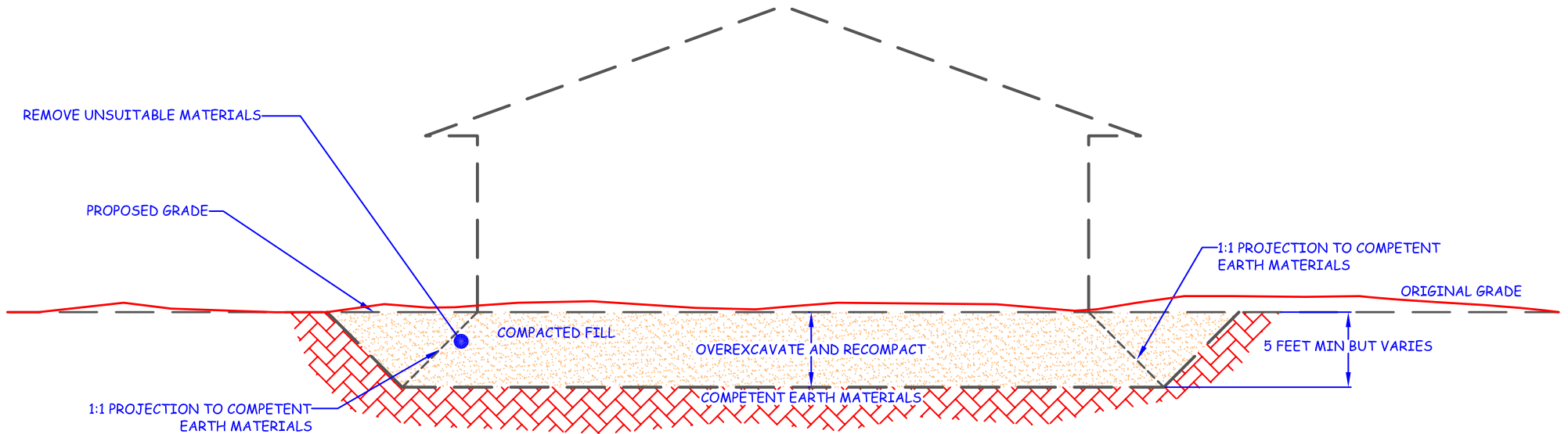

NOTE: REMOVAL BOTTOMS SHOULD BE GRADED WITH A MINIMUM 2% FALL TOWARDS STREET OR OTHER SUITABLE AREA (AS DETERMINED BY THE GEOTECHNICAL CONSULTANT) TO AVOID PONDING BELOW THE BUILDING

NOTE: WHERE DESIGN CUT LOTS ARE EXCAVATED ENTIRELY INTO COMPETENT EARTH MATERIALS, OVEREXCAVATION MAY STILL BE NEEDED FOR HARD-ROCK CONDITIONS OR MATERIALS WITH VARIABLE EXPANSION POTENTIALS

# CUT / FILL TRANSITION LOT TYPICAL DETAIL

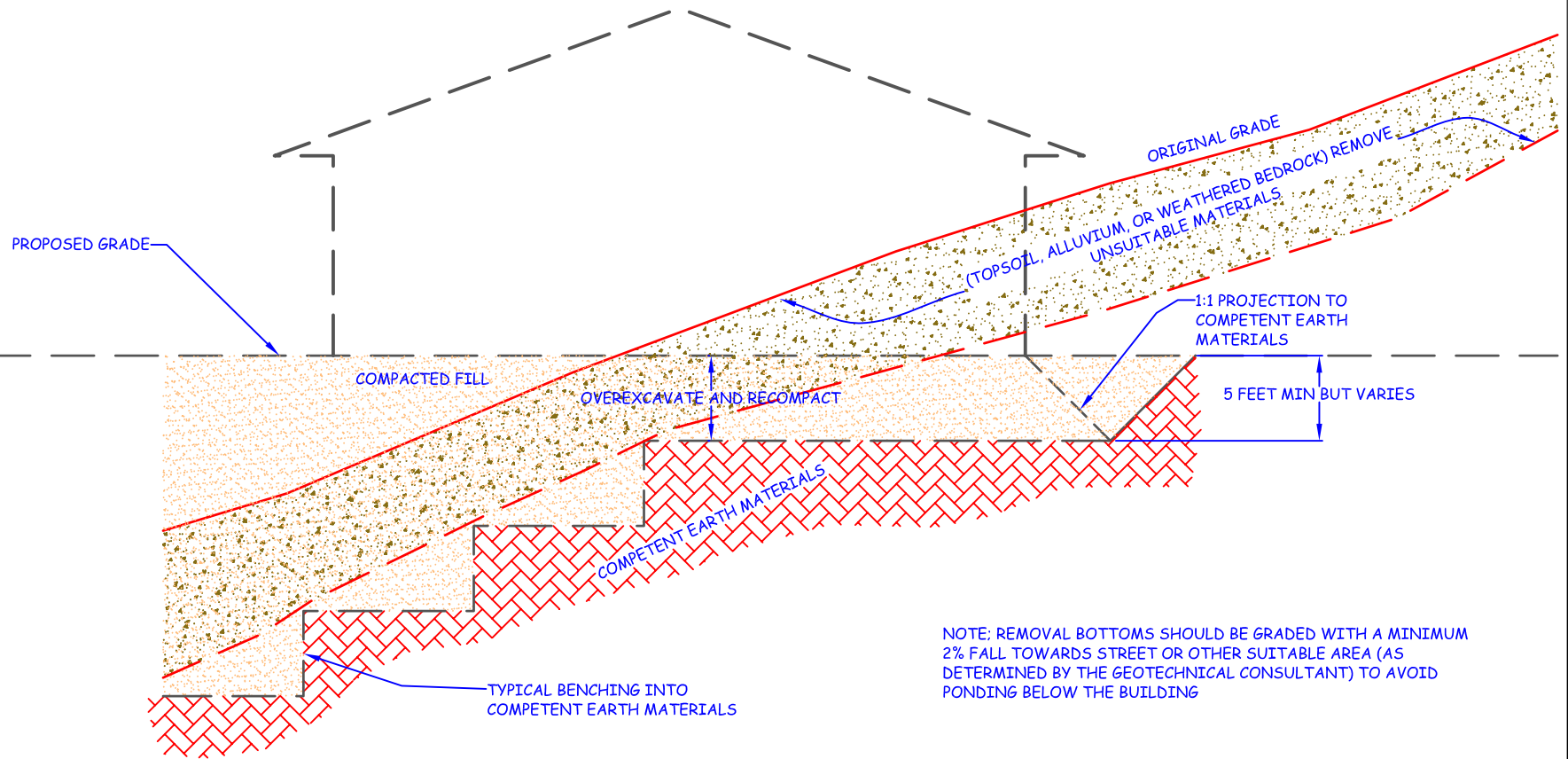

NOTE: REMOVAL BOTTOMS SHOULD BE GRADED WITH A MINIMUM 2% FALL TOWARDS STREET OR OTHER SUITABLE AREA (AS DETERMINED BY THE GEOTECHNICAL CONSULTANT) TO AVOID PONDING BELOW THE BUILDING

NOTE: WHERE DESIGN CUT LOTS ARE EXCAVATED ENTIRELY INTO COMPETENT EARTH MATERIALS, OVEREXCAVATION MAY STILL BE NEEDED FOR HARD-ROCK CONDITIONS OR MATERIALS WITH VARIABLE EXPANSION POTENTIALS

# KEYWAY & BENCHING TYPICAL DETAILS CUT OVER FILL SLOPE

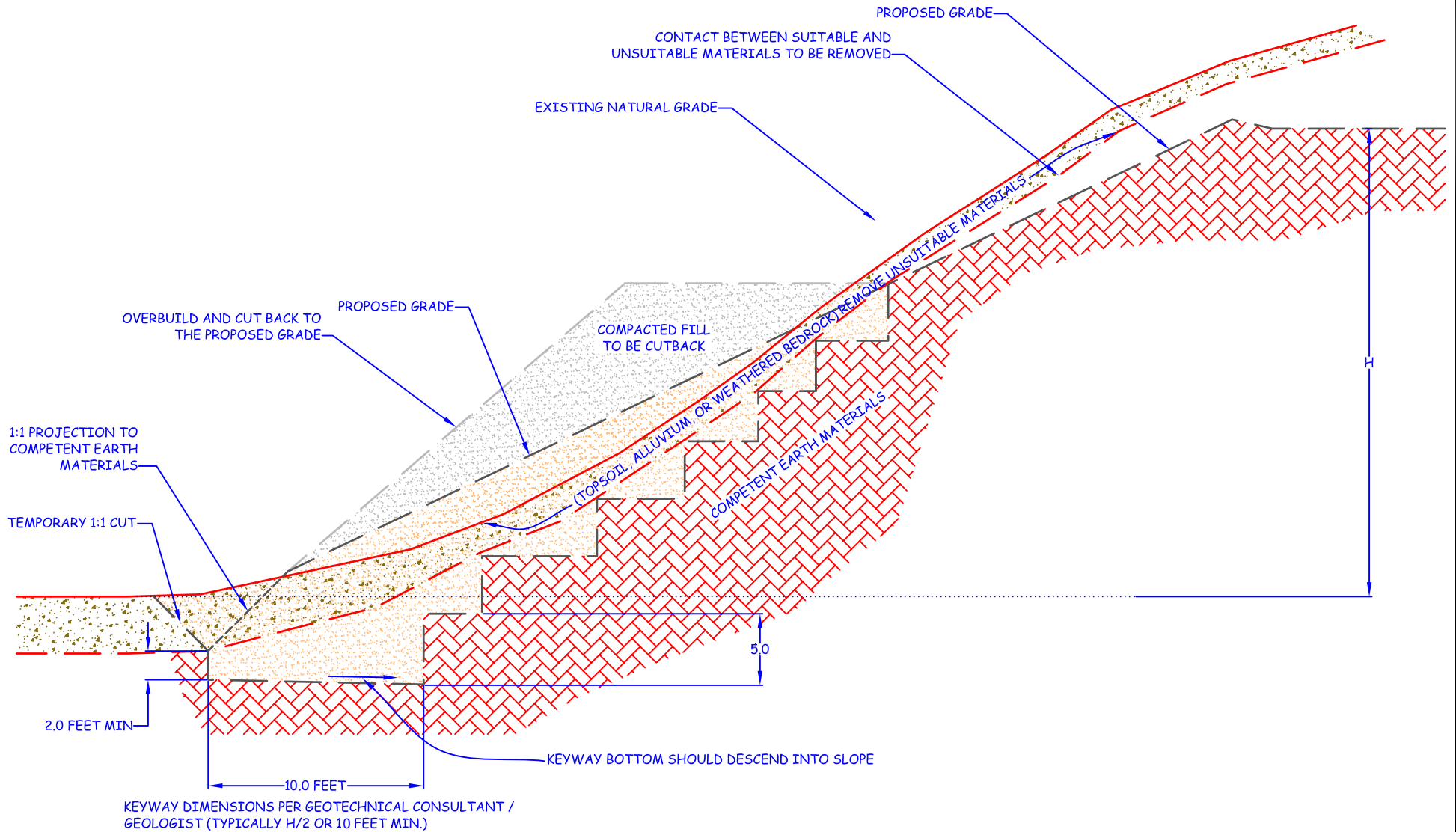

NOTE:

NATURAL SLOPES STEEPER THAN 5:1 (H:V) MUST BE BENCHING INTO COMPETENT EARTH MATERIALS

# KEYWAY & BENCHING TYPICAL DETAILS FILL OVER CUT SLOPE

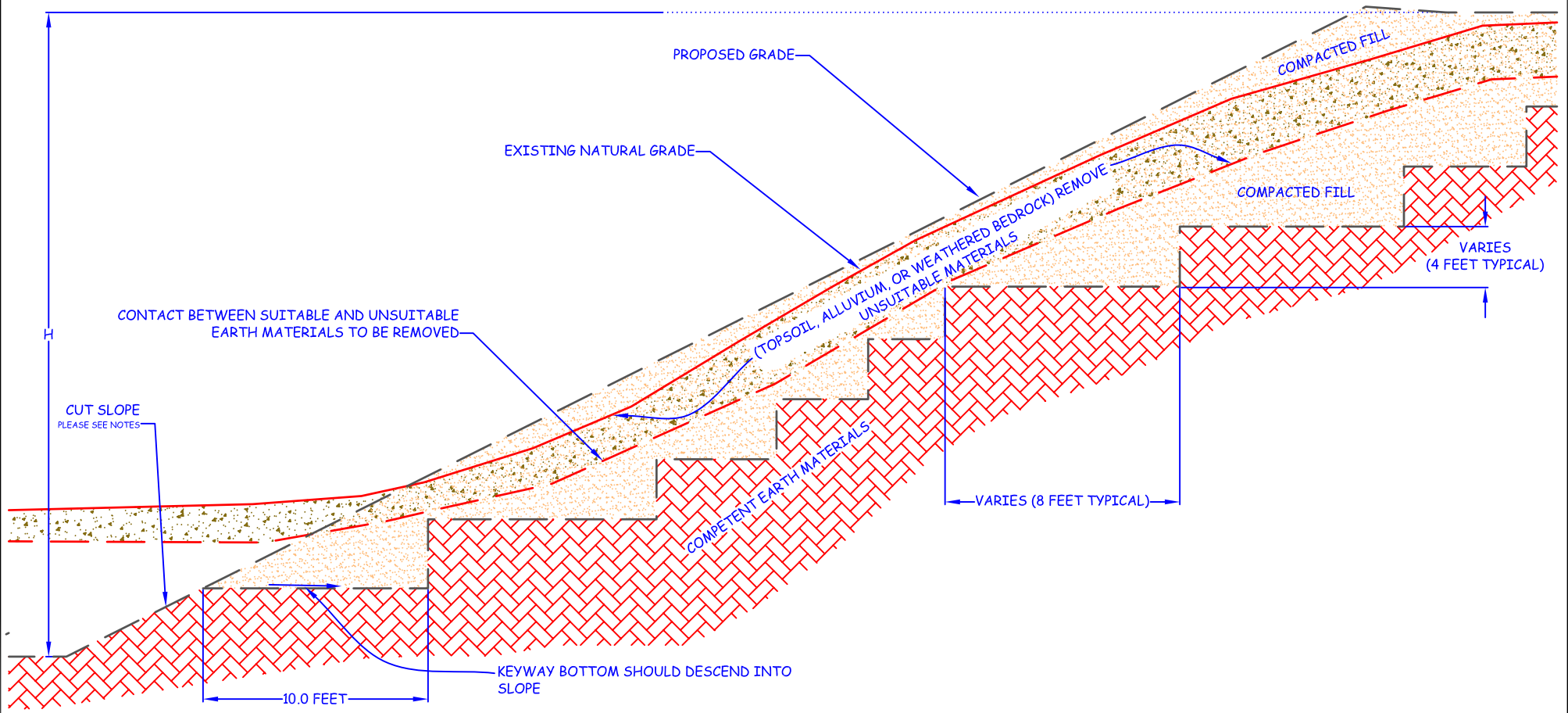

KEYWAY DIMENSIONS PER GEOTECHNICAL CONSULTANT / GEOLOGIST (TYPICALLY H/2 OR 10 FEET MIN.)

**NOTES:**

NATURAL SLOPES STEEPER THAN 5:1 (H:V) MUST BE BENCHED INTO COMPETENT EARTH MATERIALS

THE CUT SLOPE MUST BE CONSTRUCTED FIRST

# KEYWAY & BENCHING TYPICAL DETAILS FILL SLOPE

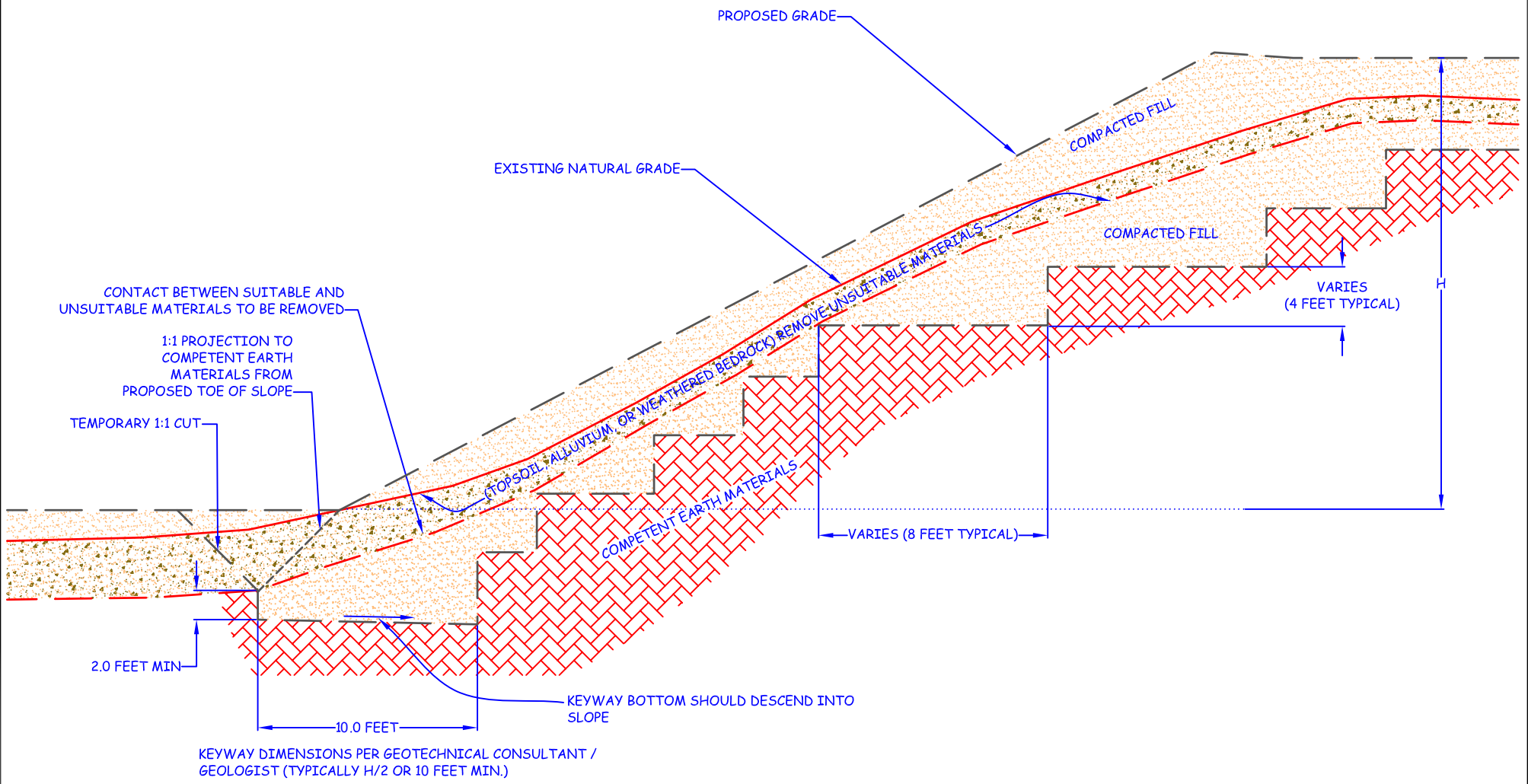

**NOTES:**

NATURAL SLOPES STEEPER THAN 5:1 (H:V) MUST BE BENCHING INTO COMPETENT EARTH MATERIALS



# OVERSIZE ROCK TYPICAL DETAIL

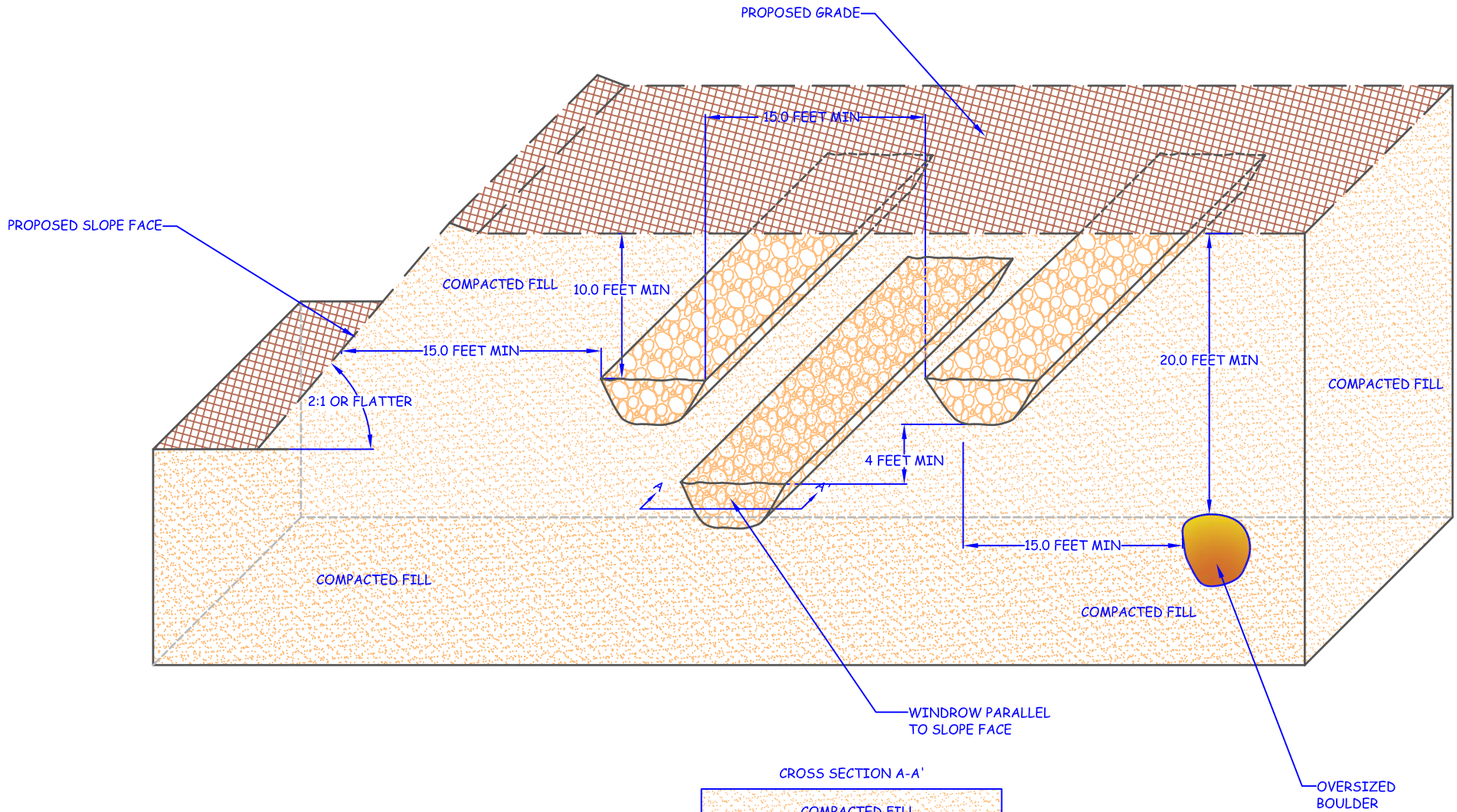

CROSS SECTION A-A'

JETTING OF APPROVED GRANULAR MATERIAL

EXCAVATED TRENCH OR DOZER V-CUT

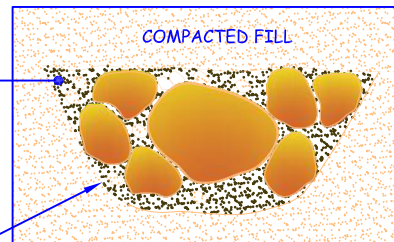

**NOTES:**

OVERSIZE ROCK IS LARGER THAN 8 INCHES IN MAX DIAMETER

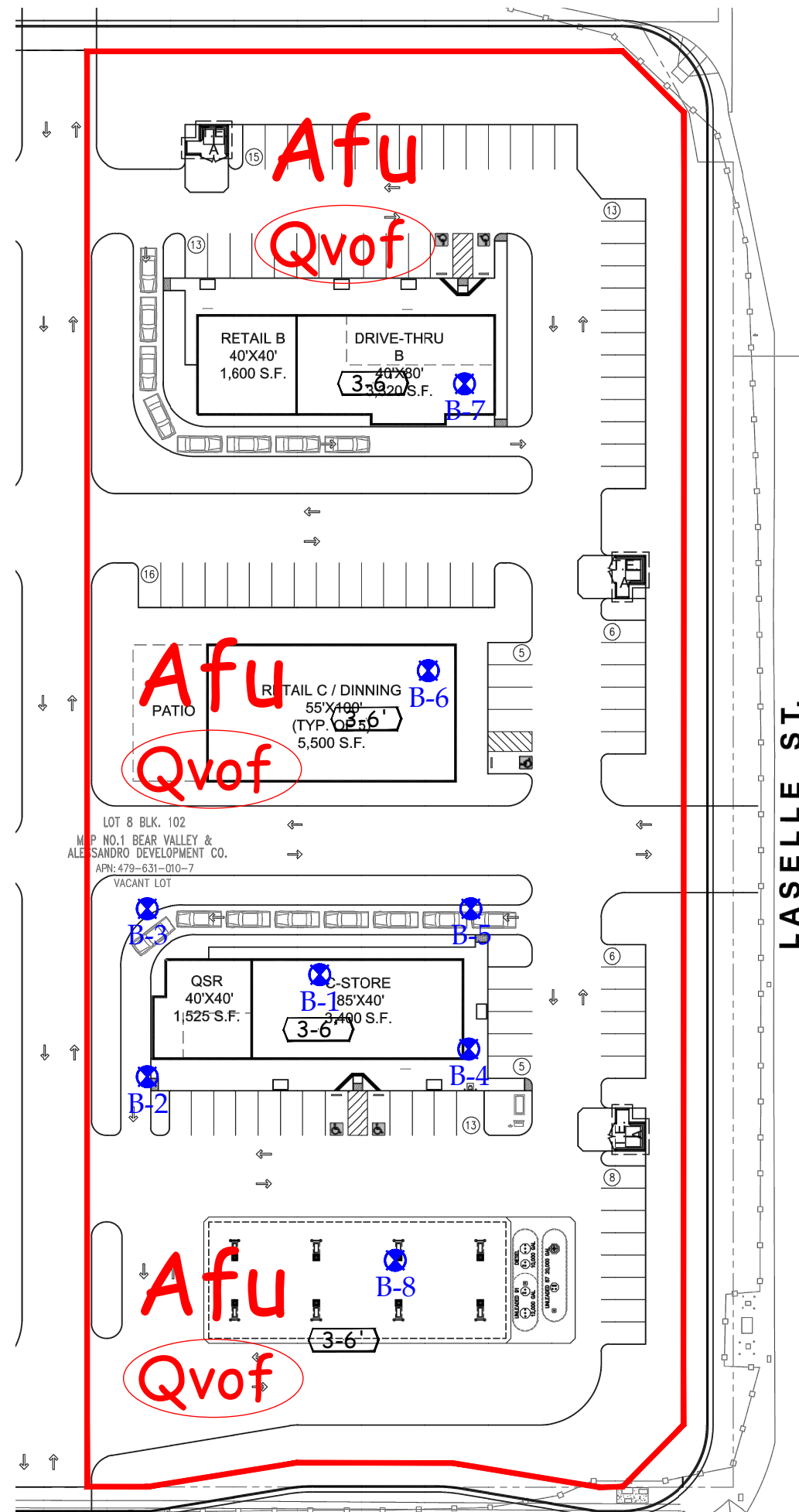

**LEGEND**

Locations are Approximate

**Geologic Units**

- Afu - Artificial Fill, Undocumented
- Qvof - Very Old Fan Deposits  
(Circled Where Buried)

**Symbols**

- Limits of Report
- Boring Location  
(By GEOBODEN INC., 2017)
- Recommended Removal Depths



**GEOTECHNICAL MAP**

LOCATED AT THE NORTH WEST CORNER OF ALESSANDRO BOULEVARD AND LASSELLE STREET  
CITY OF MORENO VALLEY, RIVERSIDE COUNTY, CALIFORNIA  
APN 479-631-010

PROJECT	LASSELLE STREET		
CLIENT	MR. ALEX HANN		
PROJECT NO.	203131-10A		
DATE	MAY 2020		
SCALE	1:60		
DWG XREFS			
REVISION			
DRAWN BY	JDG	PLATE	1 OF 1

Earth Strata Geotechnical Services, Inc.  
Geotechnical, Environmental and Materials Testing Consultants

www.ESGSINC.com (951) 397-8315



December 12, 2017  
Moreno Valley-1-01

Northwest Moreno Properties Inc  
3017 Edinger Avenue  
Tustin, CA 92780

**Subject:      Infiltration/Percolation Testing for Stormwater Retention  
Proposed 76 Gas Station  
Northwest Alessandro Boulevard/Laselle Street  
Moreno Valley, California**

As requested, we have performed percolation/infiltration testing on the subject site in order to determine the infiltration potential of the surface soils. The percolation rates determined should be useful in assessing storm water retention needs. It is our understanding that on-site storm water retention will be required. It is proposed to collect the storm water runoff within subsurface percolation swales/pits. This report presents the results of our study, discussion of our findings, and provides percolation rates for the subject system.

## **PURPOSE AND SCOPE OF SERVICES**

The purpose of this study was to determine the general percolation rates and physical characteristics of the onsite soils in order to provide design parameters for the proposed onsite infiltration system. Services provided for this study are in accordance with our agreement and consisted of the following:

- Site exploration consisting of the excavation and logging of three test holes;
- Percolation testing in the test holes (P-1, P-2 and P-3);
- Compilation of this report, which presents the results of our study and provides percolation rates for the design of an onsite infiltration system.

## **SITE DESCRIPTION AND PROPOSED DEVELOPMENT**

The site is located at northwest of Alessandro Boulevard and Laselle Street in Moreno Valley, California. The site is occupied by a vacant land. Further information regarding proposed development and test hole locations is shown on Figure 1, Percolation Test Holes Location Map.

## **FIELD INVESTIGATION**

Our field investigation consisted of excavating three shallow exploratory test holes, which were also used as percolation test holes. Hollow-stem drilling equipment was used to excavate the exploratory test holes. An engineer logged and observed the test holes excavations. Soil classification was based on visual observation. The approximate locations of the exploratory and percolation test holes are shown on Figure 1 (Percolation Test Holes Location Map). Logs of the exploratory test holes are presented in Appendix A.

## **SUBSURFACE SOILS CONDITIONS**

### SOIL PROFILE

The site is underlain by sand and silty sand with gravel. The native soils encountered within our boring consisted primarily of medium dense to dense sand and silty sand. A more detailed description of these materials is provided in the exploratory test holes logs included in the enclosed Appendix A. Soils encountered were classified according to the Unified Soil Classification System (USCS).

### GROUNDWATER

Groundwater was not encountered within the exploratory test holes to the maximum explored depth of 5 feet below ground surface (bgs). Fluctuations of the groundwater table, localized zones of perched water, and rise in soil moisture content should be anticipated during the rainy season. Irrigation of landscaped areas can also lead to an increase in soil moisture content and fluctuations of intermittent shallow perched groundwater levels.

## **PERCOLATION TESTING AND PROCEDURE**

Percolation testing was performed to assess the general percolation rates of the onsite soils for the design of an onsite infiltration system.

The continuous pre-soak (falling-head) test procedure was utilized for testing. Water was allowed to presoak in each test hole prior to obtaining test readings. Following the presoak period, the drop in water level in each hole was monitored every 10 minutes to determine the appropriate method for testing. Test holes were refilled following each reading or when the water depth was below 6 inches. Test times ranged from 120 minutes. The drop in water level was recorded to the nearest 1/10<sup>th</sup> inch to produce conservative water level readings.

## SUMMARY OF INFILTRATION TEST RESULTS

Tests results are summarized below:

Test Hole No.	Rate (Inch/Hour)
1	3
2	2.9
3	3.2

Based on the obtained field data, 2.9 inches per hour should be utilized in the design of the proposed onsite drain system. The base of the system should be founded into natural soils.

It should be noted that the infiltration rates determined are ultimate rates based upon field test results. An appropriate safety factor should be applied to account for subsoil inconsistencies and potential silting of the percolating soils. The safety factor should be determined with consideration to other factors in the storm water retention system design (particularly stormwater volume estimates) and the safety factors associated with those design components.

The Storm water Manager's Resource Center (SMRC) web site (<http://www.stormwatercenter.net/>) includes guidelines for disposal of storm water with respect to setback of structures. It is included in the criteria that infiltration facilities should be setback 10 feet down-gradient from structures. In order to avoid potential adversely impacting any existing structures, we recommend that any infiltration system be kept a horizontal distance of at least 10 feet from the edge of new building and the property line.

## LIMITATIONS

The findings and recommendations of this report were prepared in accordance with generally accepted professional engineering and engineering geologic principals and practice within our opinion at this time in Southern California. Our conclusions and recommendations are based on the results of the field investigations, combined with an interpolation of subsurface conditions between and beyond exploration locations.

As the project evolves, our continued consultation and construction monitoring should be considered. GeoBoden should review plans and specifications to ensure the recommendations presented herein have been appropriately interpreted, and that the design assumptions used in this study are valid. Where significant design changes occur, GeoBoden may be required to augment or modify these recommendations. Subsurface conditions may differ in some locations from those encountered in the explorations, and may require additional analyses and/or modified recommendations. This report was written for Client, and the design team members, and only for the proposed development described herein. We are not responsible for technical interpretations made by others, or exploratory information that has not been described or documented in this

Northwest Moreno Properties Inc

December 12, 2017

Page 4 of 5

report. Specific questions or interpretations concerning our findings and conclusions may require written clarification.

Northwest Moreno Properties Inc  
December 12, 2017  
Page 5 of 5

We appreciate the opportunity to provide service to you on this project. If you have questions regarding this letter or the data included, please contact the undersigned.

Sincerely,  
GEOBODEN, INC.



Cyrus Radvar  
Principal Engineer, G.E. 2742



Copies: 3/Addressee

Attachments:

Figure 1 – Percolation Test Holes Location Map  
Appendix A – Test Holes Logs

**ASSESSOR'S PARCEL NUMBER**  
479-631-010

**LEGAL DESCRIPTION**

THE LAND REFERRED TO HEREIN IS SITUATED IN THE COUNTY OF RIVERSIDE STATE OF CALIFORNIA AND IS DESCRIBED AS FOLLOWS: LOT 9 IN BLOCK 103 OF MAP NO. 18464 VALLEY AND ALESSANDRO DEVELOPMENT CO. IN MORENO VALLEY, COUNTY OF RIVERSIDE STATE OF CALIFORNIA AS SHOWN BY MAP ON FILE IN BOOK 11 PAGE 10 OF MAPS RECORDS OF SAN BERNARDINO COUNTY, CALIFORNIA.

**PHASE - TWO (FUTURE)**  
A = ± 5.0 ACRES

TIMO STREET

LASELLE STREET

**PROJECT DATA**

ZONING	NC - NEIGHBORHOOD COMMERCIAL
LAND USE	COMMERCIAL
SPECIFIC PLAN	SP 145
AREA OF SITE	± 144,000 S.F. (3.297 ACRE)
BLDG SETBACKS	REQUIRED PROPOSED
FRONT (NORTH)	20'-0" 88'-0" (CANOPY)
REAR (SOUTH)	20'-0" 84'-0" (CARWASH)
LEFT (WEST)	20'-0" 88'-0" (MULTI-TENANT)
RIGHT (EAST)	20'-0" (CANOPY)
LANDSCAPE AREA	± 3 MIN 24,944 S.F. (20.91%)
FLOOR AREA RATIO	± 3.00X
MAXIMUM HEIGHT	± 30'-4"
PARKING	85 84

**BUILDING DATA**

<b>(1A) MULTI-TENANT RETAIL</b>		
AREAS	DRIVE THRU REST.	1,600 SF
	RETAIL	1,250 SF
	G.S.R.	1,250 SF
	C-STORE	3,000 SF
	TOTAL	5,350 SF
OCCUPANCY	M - A2	
TYPE OF CONST	V-B	
NUMBER OF STORY	1	
BLDG HEIGHT	± 20'-0"	
SPRINKLERS	XX	
<b>(1B) RETAIL BLDG</b>		
AREA	RETAIL	5,500 SF
	TOTAL	5,500 SF
OCCUPANCY	M	
TYPE OF CONST	V-B	
NUMBER OF STORY	1	
BLDG HEIGHT	± 20'-0"	
SPRINKLERS	XX	
<b>(2) CANOPY</b>		
AREA		3,072 SF
OCCUPANCY	M	
TYPE OF CONST	11-B	
NUMBER OF STORY	1	
BLDG HEIGHT	27'-0"	
<b>(3) CARWASH</b>		
AREA		4,820 SF
OCCUPANCY	B	
TYPE OF CONST	V-B	
NUMBER OF STORY	1	
BLDG HEIGHT	24'-0"	

<b>PARKING COMPUTATION</b>		
TYPE	SIZE	
REGULAR	4'-0" X 18'-0"	
PARALLEL	4'-0" X 22'-0"	
COMPACT	7'-0" X 18'-0"	
HANDICAP	VAN ACCESSIBLE	
	8'-0" X 16'-0" (UP TO 5% OF REGD SP)	
USE	FORMULA	REQUIRED PROVIDED
DRIVE THRU R.	(1/100 S.P.)	16 16
RETAIL	(1/225 S.P.)	6 6
G.S.R.	(1/100 S.P.)	6 6
RETAIL	(1/225 S.P.)	6 6
C-STORE	(1/225 S.P.)	14 14
RETAIL	(1/225 S.P.)	15 15
CARWASH	(1/2 + 1 PER 2 EMPLOYEES)	12 24
TOTAL PARKING		85 84

<b>HANDICAP PARKING REQUIREMENTS</b>		
FORMULA	REQUIRED	PROVIDED
76-100 PARKING SPACES	(4)	(5)
<b>CLEAN AIR VEHICLE PARKING</b>		
FORMULA	REQUIRED	PROVIDED
24 (11,040 V.V. MIN CODE (5% OF TOTAL PARKING SP))	(8)	(0)
<b>OTHER PARKING REQUIREMENTS</b>		
DINE PARKING		
CLASS 2 OR 3 (MIN OF TWO BICYCLE PARKING STALLS)	REQUIRED: 5% OF TOTAL REGD PARKING SP	
LOADING SPACE	REQUIRED: 1 SP (0 - 24,999 TOTAL S.F.A.)	

**LEGEND**

**B-1**

**NUMBER AND APPROXIMATE LOCATION OF BORING**

**LEGEND**

- NO. OF PARKING SPACES
- ACCESSIBLE PARKING
- PROPERTY LINE
- ADA PATH OF TRAVEL
- CONCRETE PAVING AREA
- DESIGNATED PAVING AREA
- LANDSCAPED AREA
- COMMUNITY TRAIL
- STREET DEDICATION
- DIRECTIONAL ARROW
- AREA LIGHTS
- WALL MOUNTED DECORATIVE AREA LIGHTS
- FIRE HYDRANT
- SEWER MANHOLE
- ISHER GLE-VALVE
- POLE HOLE
- WATER METER
- WATER POINT
- SIGN

**SITE KEY NOTES**

- (1A) MULTI-TENANT RETAIL BUILDING
- (1B) RETAIL BUILDING
- (2) GAS STATION CANOPY AND FUEL DISPENSERS
- (2A) UNDERGROUND STORAGE TANKS
- (2B) VENT RISER WITH CARBON VAPOR CAPSTER
- (3) CARWASH BUILDING
- (3A) CARWASH PAY STATION WITH TELLER
- (3B) CARWASH AUTOMATIC WASH BRUSH
- (3C) CARWASH CENTRAL VACUUM EQUIPMENT
- (3D) CARWASH WATER CLAMPER
- (3E) CARWASH PAY KIOSK
- (4A) PARKING STRIPS AS PER CITY STANDARDS (WITH WHEELSTOP HERE REQUIRED)
- (4B) ACCESSIBLE PARKING STRIPS (WITH WHEELSTOP WHERE REQUIRED)
- (4C) ACCESSIBLE PARKING SIGN
- (4D) ADA ACCESSIBLE RAMP AND TRUNCATED DOME PAVEMENT
- (4E) ADA ACCESSIBLE PATH STRIPS (3% MAX SLOPE / 2% MAX CROSS SLOPE)
- (5) DESIGNATED CLEAN AIR VEHICLE PARKING
- (6) LANDSCAPE WITH 6" CONCRETE CURB TO RETAIN
- (7) SIGNALLING
- (8A) SIGNATURE PAVING
- (8B) CONCRETE SIDEWALK AND CURB
- (9) (N) DRIVEWAY PER CITY STANDARDS
- (10) TRASH ENCLOSURE PER CITY STANDARDS
- (11) LOADING SPACE 10' X 22'
- (12) ALL ASBESTOS REMOVED FROM ALL PAVING SURFACES (SEE SHEET 10)
- (13) AIR WATER VALVE
- (14) AREA LIGHTS
- (15) FIRE TRUCK PATH OF TRAVEL
- (16) FUEL TANKER/TRASH TRUCK PATH OF TRAVEL
- (17) TOWMENT SIGN (UNDER SEPARATE PERMIT)
- (17A) GAS STATION PRICE SIGN (UNDER SEPARATE PERMIT)
- (17B) CARWASH PRICE SIGN (UNDER SEPARATE PERMIT)
- (18) PROPOSED TRANSPARENT PAD LOCATION

3807 E. LA PALMA, STE. 707  
MORENO VALLEY, CA 92553  
TEL: 760-939-9300 FAX: 760-939-1000  
WWW.ALESSANDROBLV.COM

**CONSULTANT'S SEALS**

**SUBMITTAL**  
NO. DESCRIPTION BY DATE

**REVISIONS**  
NO. DESCRIPTION BY DATE

**OWNER NAME & ADDRESS**  
NORTHWEST MORENO PROPERTIES, INC.  
3917 ENDORGE AVE.  
TUSTIN, CA 92780

**PROJECT NAME & ADDRESS**  
76 GAS STATION  
C-STORE / G.S.R.  
CARWASH

**DATE DRAWING**  
11-27-17

**SHEET TITLE**  
PROPOSED SITE PLAN

**DESIGNED BY:** WS  
**DRAWN BY:** WS  
**CHECKED BY:** JK

**CONFIDENTIALITY STATEMENT**  
THIS DRAWING IS THE PROPERTY OF ALESSANDRO BLV & LASELLE ST. IT IS TO BE USED ONLY FOR THE PROJECT AND SITE SPECIFICALLY IDENTIFIED HEREIN. IT IS NOT TO BE REPRODUCED, COPIED, OR TRANSMITTED IN ANY FORM OR BY ANY MEANS, ELECTRONIC OR MECHANICAL, INCLUDING PHOTOCOPYING, RECORDING, OR BY ANY INFORMATION STORAGE AND RETRIEVAL SYSTEM, WITHOUT THE WRITTEN PERMISSION OF ALESSANDRO BLV & LASELLE ST. ANY UNAUTHORIZED USE OF THIS DRAWING IS STRICTLY PROHIBITED. ALESSANDRO BLV & LASELLE ST. ACCEPTS NO LIABILITY FOR ANY DAMAGE, LOSS, OR INJURY, INCLUDING CONSEQUENTIAL DAMAGES, ARISING FROM THE USE OF THIS DRAWING, WHETHER CAUSED BY NEGLIGENCE OR OTHERWISE.

**AS-1.0**  
JOB NO. E87517  
SHEET NO.



**CLIENT** Northwest Moreno Properties Inc  
**PROJECT NUMBER** Moreno Valley-2-01  
**DATE STARTED** 12/9/17 **COMPLETED** 12/9/17  
**DRILLING CONTRACTOR** GeoBoden, Inc.  
**DRILLING METHOD** HSA  
**LOGGED BY** C.R. **CHECKED BY** \_\_\_\_\_  
**NOTES** \_\_\_\_\_

**PROJECT NAME** Proposed 76 Gas Station  
**PROJECT LOCATION** Alessandro Boulevard/Laselle Street, Moreno Valley  
**GROUND ELEVATION** \_\_\_\_\_ **HOLE SIZE** 8 inches  
**GROUND WATER LEVELS:**  
**AT TIME OF DRILLING** ---  
**AT END OF DRILLING** ---  
**AFTER DRILLING** ---

GEOTECH BH COLUMNS - GINT STD US LAB.GDT - 12/12/17 11:26 - C:\PASSPORT\GB\176 GAS STATION\PERCOLATION\LOGS.GPJ

DEPTH (ft)	GRAPHIC LOG	MATERIAL DESCRIPTION	SAMPLE TYPE NUMBER	RECOVERY % (RQD)	BLOW COUNTS (N VALUE)	POCKET PEN. (tsf)	DRY UNIT WT. (pcf)	MOISTURE CONTENT (%)	ATTERBERG LIMITS			FINES CONTENT (%)
									LIQUID LIMIT	PLASTIC LIMIT	PLASTICITY INDEX	
0.0		SAND w. GRAVEL (SP): light brown, moist										
2.5												
5.0												

Bottom of borehole at 11.5 feet below ground surface. Boring was backfilled with cuttings. No groundwater was encountered at the time of drilling.  
 Bottom of borehole at 5.0 feet.

**CLIENT** Northwest Moreno Properties Inc  
**PROJECT NUMBER** Moreno Valley-2-01  
**DATE STARTED** 12/9/17 **COMPLETED** 12/9/17  
**DRILLING CONTRACTOR** GeoBoden, Inc.  
**DRILLING METHOD** HSA  
**LOGGED BY** C.R. **CHECKED BY** \_\_\_\_\_  
**NOTES** \_\_\_\_\_

**PROJECT NAME** Proposed 76 Gas Station  
**PROJECT LOCATION** Alessandro Boulevard/Laselle Street, Moreno Valley  
**GROUND ELEVATION** \_\_\_\_\_ **HOLE SIZE** 8 inches  
**GROUND WATER LEVELS:**  
**AT TIME OF DRILLING** ---  
**AT END OF DRILLING** ---  
**AFTER DRILLING** ---

GEOTECH BH COLUMNS - GINT STD US LAB.GDT - 12/12/17 11:26 - C:\PASSPORT\GB\176 GAS STATION\PERCOLATION\LOGS.GPJ

DEPTH (ft)	GRAPHIC LOG	MATERIAL DESCRIPTION	SAMPLE TYPE NUMBER	RECOVERY % (RQD)	BLOW COUNTS (N VALUE)	POCKET PEN. (tsf)	DRY UNIT WT. (pcf)	MOISTURE CONTENT (%)	ATTERBERG LIMITS			FINES CONTENT (%)
									LIQUID LIMIT	PLASTIC LIMIT	PLASTICITY INDEX	
0.0		SILTY SAND (SM): brown, dry										
2.5												
5.0												

Bottom of borehole at 5 feet below ground surface. Boring was backfilled with cuttings. No groundwater was encountered at the time of drilling.  
 Bottom of borehole at 5.0 feet.

CLIENT Northwest Moreno Properties Inc  
 PROJECT NUMBER Moreno Valley-2-01  
 DATE STARTED 12/9/17 COMPLETED 12/9/17  
 DRILLING CONTRACTOR GeoBoden, Inc.  
 DRILLING METHOD HSA  
 LOGGED BY C.R. CHECKED BY \_\_\_\_\_  
 NOTES \_\_\_\_\_

PROJECT NAME Proposed 76 Gas Station  
 PROJECT LOCATION Alessandro Boulevard/Laselle Street, Moreno Valley  
 GROUND ELEVATION \_\_\_\_\_ HOLE SIZE 8 inches  
 GROUND WATER LEVELS:  
 AT TIME OF DRILLING ---  
 AT END OF DRILLING ---  
 AFTER DRILLING ---

DEPTH (ft)	GRAPHIC LOG	MATERIAL DESCRIPTION	SAMPLE TYPE NUMBER	RECOVERY % (RQD)	BLOW COUNTS (N VALUE)	POCKET PEN. (tsf)	DRY UNIT WT. (pcf)	MOISTURE CONTENT (%)	ATTERBERG LIMITS			FINES CONTENT (%)
									LIQUID LIMIT	PLASTIC LIMIT	PLASTICITY INDEX	
0.0		SILTY SAND (SM): brown, moist										
2.5												
5.0							115	2				
Bottom of borehole at 5 feet below ground surface. Boring was backfilled with cuttings. No groundwater was encountered at the time of drilling. Bottom of borehole at 5.0 feet.												

GEOTECH BH COLUMNS - GINT STD US LAB.GDT - 12/12/17 11:26 - C:\PASSPORT\GB\176 GAS STATION\PERCOLATION\LOGS.GPJ

# Appendix 4: Historical Site Conditions

*Phase I Environmental Site Assessment or Other Information on Past Site Use*



# WQMP Project Report

## County of Riverside Stormwater Program

Santa Ana River Watershed Geodatabase

Tuesday, January 11, 2022

Note: The information provided in this report and on the Stormwater Geodatabase for the County of Riverside Stormwater Program is intended to provide basic guidance in the preparation of the applicant's Water Quality Management Plan (WQMP) and should not be relied upon without independent verification.

<b>Project Site Parcel Number(s):</b>	479631003, 479631010, 479631007, RW, 479631002, 479631004, 479631001, 479631005, 479631006, 479631009
<b>Latitude/Longitude:</b>	33.9183, -117.2101
<b>Thomas Brothers Page:</b>	
<b>Project Site Acreage:</b>	9.03
<b>Watershed(s):</b>	SANTA ANA
<b>This Project Site Resides in the following Hydrologic Unit(s) (HUC):</b>	<b>HUC Name - HUC Number</b> <b>Moreno Valley - 180702020304</b>
<b>The HUCs Contribute stormwater to the following 303d listed water bodies and TMDLs which may include drainage from your proposed Project Site:</b>	<b>WBID Name - WBID Number</b> <b>Canyon Lake (Railroad Canyon Reservoir) - CAL8021100019990208151525</b> <b>Elsinore, Lake - CAL8023100019990208151100</b>
<b>These 303d listed Water bodies and TMDLs have the following Pollutants of Concern (POC):</b>	<b>Bacterial Indicators - Pathogens</b> <b>Nutrients - Nutrients, Organic Enrichment/Low Dissolved Oxygen</b> <b>Other Organics - PCBs (Polychlorinated biphenyls)</b> <b>Toxicity - Sediment Toxicity, Unknown Toxicity</b>
<b>Is the Site subject to Hydromodification:</b>	Yes
<b>Limitations on Infiltration:</b>	<b>Project Site Onsite Soils Group(s) - B, C, D</b> <b>Known Groundwater Contamination Plumes within 1000' - No</b> <b>Adjacent Water Supply Wells(s) - No information available please contact your local water agency for more information. Your local contact agency is EASTERN MUNICIPAL W.D.. Your local wholesaler contact agency is METROPOLITAN WATER DISTRICT.</b>
<b>Environmentally Sensitive Areas within 200'(Fish and Wildlife Habitat/Species):</b>	None
<b>Environmentally Sensitive Areas within 200'(CVMSHCP):</b>	None
<b>Environmentally Sensitive Areas within 200'(WRMSHCP):</b>	Burrowing Owl Survey Required Area
<b>Groundwater elevation from Mean Sea Level:</b>	1509
<b>85th Percentile Design Storm Depth</b>	0.653

(in):

**Groundwater Basin:**

Perris-North

**MSHCP/CVMSHCP Criteria Cell(s):**

No Data

**Retention Ordinance Information:**

No Data

**Studies and Reports Related to  
Project Site:**

[Comprehensive Nutrient Reduction Plan](#)

[IBI Scores - Southern Cal](#)

[bulletin118\\_4-sc](#)

[water\\_fact\\_3\\_7.11](#)

[8039-SAR-Hydromodification](#)

[Sunnymead MDP](#)

[West San Jacinto GW Basin Management Plan](#)

[Sunnymead ADP Map](#)

[Sunnymead ADP Report](#)

# Appendix 5: LID Infeasibility

*LID Technical Infeasibility Analysis*

# Appendix 6: BMP Design Details

*BMP Sizing, Design Details and other Supporting Documentation*



**Santa Ana Watershed - BMP Design Volume,  $V_{BMP}$**

(Rev. 10-2011)

Legend:

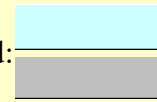

Required Entries

Calculated Cells

*(Note this worksheet shall **only** be used in conjunction with BMP designs from the **LID BMP Design Handbook**)*

Company Name **Plump Engineering Inc.**

Date **1/17/2022**

Designed by

Case No

Company Project Number/Name

**Moreno Valley Commercial Center**

**BMP Identification**

BMP NAME / ID **Infiltration Trench 1 INF-1**

*Must match Name/ID used on BMP Design Calculation Sheet*

**Design Rainfall Depth**

85th Percentile, 24-hour Rainfall Depth,  
from the Isohyetal Map in Handbook Appendix E

$D_{85} =$  **0.65** inches

**Drainage Management Area Tabulation**

*Insert additional rows if needed to accommodate all DMAs draining to the BMP*

DMA Type/ID	DMA Area (square feet)	Post-Project Surface Type	Effective Imperivous Fraction, $I_f$	DMA Runoff Factor	DMA Areas x Runoff Factor	Design Storm Depth (in)	Design Capture Volume, $V_{BMP}$ (cubic feet)	Proposed Volume on Plans (cubic feet)
DMA-1	135761	Mixed Surface Types	0.748	0.54	73530.8			
	<b>135761</b>	<b>Total</b>			<b>73530.8</b>	<b>0.65</b>	<b>3982.9</b>	<b>10,345</b>

Notes:

**Santa Ana Watershed - BMP Design Volume,  $V_{BMP}$**

(Rev. 10-2011)

Legend:

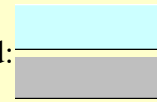

Required Entries

Calculated Cells

*(Note this worksheet shall **only** be used in conjunction with BMP designs from the **LID BMP Design Handbook**)*

Company Name **Plump Engineering Inc.**

Date **1/1/1900**

Designed by

Case No

Company Project Number/Name

**Moreno Valley Commercial Center**

**BMP Identification**

BMP NAME / ID **Infiltration Trench 1 INF-2**

*Must match Name/ID used on BMP Design Calculation Sheet*

**Design Rainfall Depth**

85th Percentile, 24-hour Rainfall Depth,  
from the Isohyetal Map in Handbook Appendix E

$D_{85} =$  **0.65** inches

**Drainage Management Area Tabulation**

*Insert additional rows if needed to accommodate all DMAs draining to the BMP*

DMA Type/ID	DMA Area (square feet)	Post-Project Surface Type	Effective Imperivous Fraction, $I_f$	DMA Runoff Factor	DMA Areas x Runoff Factor	Design Storm Depth (in)	Design Capture Volume, $V_{BMP}$ (cubic feet)	Proposed Volume on Plans (cubic feet)
DMA-2	211500	Mixed Surface Types	0.769	0.56	119312.6			
	<b>211500</b>	<b>Total</b>			<b>119312.6</b>	<b>0.65</b>	<b>6462.8</b>	<b>16,502</b>

Notes:

**Santa Ana Watershed - BMP Design Volume,  $V_{BMP}$**

(Rev. 10-2011)

Legend:

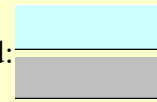

Required Entries

Calculated Cells

*(Note this worksheet shall **only** be used in conjunction with BMP designs from the **LID BMP Design Handbook**)*

Company Name **Plump Engineering Inc.**

Date **1/17/2022**

Designed by

Case No

Company Project Number/Name

**Moreno Valley Commercial Center**

**BMP Identification**

BMP NAME / ID **Infiltration Trench 1 INF-3**

*Must match Name/ID used on BMP Design Calculation Sheet*

**Design Rainfall Depth**

85th Percentile, 24-hour Rainfall Depth,  
from the Isohyetal Map in Handbook Appendix E

$D_{85} =$  **0.65** inches

**Drainage Management Area Tabulation**

*Insert additional rows if needed to accommodate all DMAs draining to the BMP*

DMA Type/ID	DMA Area (square feet)	Post-Project Surface Type	Effective Imperivous Fraction, $I_f$	DMA Runoff Factor	DMA Areas x Runoff Factor	Design Storm Depth (in)	Design Capture Volume, $V_{BMP}$ (cubic feet)	Proposed Volume on Plans (cubic feet)
DMA-3	81584	Mixed Surface Types	0.947	0.80	65442.4			
	<b>81584</b>	<b>Total</b>			<b>65442.4</b>	<b>0.65</b>	<b>3544.8</b>	<b>6,263</b>

Notes:

**Santa Ana Watershed - BMP Design Volume,  $V_{BMP}$**

(Rev. 10-2011)

Legend:

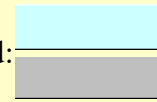

Required Entries

Calculated Cells

*(Note this worksheet shall **only** be used in conjunction with BMP designs from the **LID BMP Design Handbook**)*

Company Name **Plump Engineering Inc.**

Date **1/17/2022**

Designed by

Case No

Company Project Number/Name

**Moreno Valley Commercial Center**

**BMP Identification**

BMP NAME / ID **Infiltration Trench 1 INF-4**

*Must match Name/ID used on BMP Design Calculation Sheet*

**Design Rainfall Depth**

85th Percentile, 24-hour Rainfall Depth,  
from the Isohyetal Map in Handbook Appendix E

$D_{85} =$  **0.65** inches

**Drainage Management Area Tabulation**

*Insert additional rows if needed to accommodate all DMAs draining to the BMP*

DMA Type/ID	DMA Area (square feet)	Post-Project Surface Type	Effective Imperivous Fraction, $I_f$	DMA Runoff Factor	DMA Areas x Runoff Factor	Design Storm Depth (in)	Design Capture Volume, $V_{BMP}$ (cubic feet)	Proposed Volume on Plans (cubic feet)
DMA-4	17614	Mixed Surface Types	0.897	0.73	12786.5			
	<b>17614</b>	<b>Total</b>			<b>12786.5</b>	<b>0.65</b>	<b>692.6</b>	<b>1,243</b>

Notes:

Infiltration Trench - Design Procedure		BMP ID	Legend:	Required Entries
		INF-1		Calculated Cells
Company Name:	Plump Engineering inc.		Date:	7/27/2022
Designed by:			County/City Case No.:	
<b>Design Volume</b>				
Enter the area tributary to this feature, Max = 10 acres			$A_t =$	3 acres
Enter $V_{BMP}$ determined from Section 2.1 of this Handbook			$V_{BMP} =$	3,983 ft <sup>3</sup>
<b>Calculate Maximum Depth of the Reservoir Layer</b>				
Enter Infiltration rate			$I =$	2.6 in/hr
Enter Factor of Safety, FS (unitless)			$FS =$	3
<i>Obtain from Table 1, Appendix A: "Infiltration Testing" of this BMP Handbook</i>				
Calculate $D_1$ .			$D_1 =$	12.85 ft
$D_1 = \frac{I \text{ (in/hr)} \times 72 \text{ hrs}}{12 \text{ (in/ft)} \times (n/100) \times FS}$			$n =$	40 %
Enter depth to historic high groundwater mark (measured from finished grade)				20 ft
Enter depth to top of bedrock or impermeable layer (measured from finished grade)				15 ft
$D_2$ is the smaller of:				
Depth to groundwater - 11 ft; & Depth to impermeable layer - 6 ft			$D_2 =$	9.0 ft
$D_{MAX}$ is the smaller value of $D_1$ and $D_2$ , must be less than or equal to 8 feet.			$D_{MAX} =$	8.0 ft
<b>Trench Sizing</b>				
Enter proposed reservoir layer depth $D_R$ , must be $\leq D_{MAX}$			$D_R =$	7.00 ft
Calculate the design depth of water, $d_w$				
Design $d_w = (D_R) \times (n/100)$			Design $d_w =$	2.80 ft
Minimum Surface Area, $A_S$			$A_S =$	1,422 ft <sup>2</sup>
			$A_S = \frac{V_{BMP}}{d_w}$	
Proposed Design Surface Area			$A_D =$	3,695 ft <sup>2</sup>
Minimum Width = $D_R + 1$ foot pea gravel				8.00 ft
Sediment Control Provided? (Use pulldown)		Yes		
Geotechnical report attached? (Use pulldown)		Yes		
<small>If the trench has been designed correctly, there should be no error messages on the spreadsheet.</small>				
Notes:		Sediment Control via Filter Strip		
$V = d_w * A_d$ , $V = 10,345.6$ CF				

Infiltration Trench - Design Procedure		BMP ID	Legend:	Required Entries
		INF-2		Calculated Cells
Company Name:	Plump Engineering inc.		Date:	7/27/2022
Designed by:			County/City Case No.:	
<b>Design Volume</b>				
Enter the area tributary to this feature, Max = 10 acres			$A_t =$	5 acres
Enter $V_{BMP}$ determined from Section 2.1 of this Handbook			$V_{BMP} =$	6,463 ft <sup>3</sup>
<b>Calculate Maximum Depth of the Reservoir Layer</b>				
Enter Infiltration rate			$I =$	1.6 in/hr
Enter Factor of Safety, FS (unitless)			$FS =$	3
<i>Obtain from Table 1, Appendix A: "Infiltration Testing" of this BMP Handbook</i>				
Calculate $D_1$ .			$D_1 =$	8.00 ft
$D_1 = \frac{I \text{ (in/hr)} \times 72 \text{ hrs}}{12 \text{ (in/ft)} \times (n/100) \times FS}$			$n =$	40 %
Enter depth to historic high groundwater mark (measured from finished grade)				20 ft
Enter depth to top of bedrock or impermeable layer (measured from finished grade)				15 ft
$D_2$ is the smaller of:				
Depth to groundwater - 11 ft; & Depth to impermeable layer - 6 ft			$D_2 =$	9.0 ft
$D_{MAX}$ is the smaller value of $D_1$ and $D_2$ , must be less than or equal to 8 feet.			$D_{MAX} =$	8.0 ft
<b>Trench Sizing</b>				
Enter proposed reservoir layer depth $D_R$ , must be $\leq D_{MAX}$			$D_R =$	7.00 ft
Calculate the design depth of water, $d_w$				
Design $d_w = (D_R) \times (n/100)$			Design $d_w =$	2.80 ft
Minimum Surface Area, $A_S$			$A_S =$	2,308 ft <sup>2</sup>
			$A_S = \frac{V_{BMP}}{d_w}$	
Proposed Design Surface Area			$A_D =$	5,894 ft <sup>2</sup>
Minimum Width = $D_R + 1$ foot pea gravel				8.00 ft
Sediment Control Provided? (Use pulldown)		Yes		
Geotechnical report attached? (Use pulldown)		Yes		
If the trench has been designed correctly, there should be no error messages on the spreadsheet.				
Notes:		Sediment Control via Filter Strip		
$V = d_w * A_d$ , $V = 16,502.6$ CF				

Infiltration Trench - Design Procedure		BMP ID	Legend:	Required Entries
		INF-3		Calculated Cells
Company Name:	Plump Engineering inc.		Date:	7/27/2022
Designed by:			County/City Case No.:	
<b>Design Volume</b>				
Enter the area tributary to this feature, Max = 10 acres			$A_t =$	2 acres
Enter $V_{BMP}$ determined from Section 2.1 of this Handbook			$V_{BMP} =$	3,545 ft <sup>3</sup>
<b>Calculate Maximum Depth of the Reservoir Layer</b>				
Enter Infiltration rate			$I =$	1.6 in/hr
Enter Factor of Safety, FS (unitless)			$FS =$	3
<i>Obtain from Table 1, Appendix A: "Infiltration Testing" of this BMP Handbook</i>				
Calculate $D_1$ .			$D_1 =$	8.00 ft
$D_1 = \frac{I \text{ (in/hr)} \times 72 \text{ hrs}}{12 \text{ (in/ft)} \times (n/100) \times FS}$			$n =$	40 %
Enter depth to historic high groundwater mark (measured from finished grade)				20 ft
Enter depth to top of bedrock or impermeable layer (measured from finished grade)				15 ft
$D_2$ is the smaller of:				
Depth to groundwater - 11 ft; & Depth to impermeable layer - 6 ft			$D_2 =$	9.0 ft
$D_{MAX}$ is the smaller value of $D_1$ and $D_2$ , must be less than or equal to 8 feet.			$D_{MAX} =$	8.0 ft
<b>Trench Sizing</b>				
Enter proposed reservoir layer depth $D_R$ , must be $\leq D_{MAX}$			$D_R =$	7.00 ft
Calculate the design depth of water, $d_w$				
Design $d_w = (D_R) \times (n/100)$			Design $d_w =$	2.80 ft
Minimum Surface Area, $A_S$			$A_S =$	1,266 ft <sup>2</sup>
			$A_S = \frac{V_{BMP}}{d_w}$	
Proposed Design Surface Area			$A_D =$	2,237 ft <sup>2</sup>
Minimum Width = $D_R + 1$ foot pea gravel				8.00 ft
Sediment Control Provided? (Use pulldown)		Yes		
Geotechnical report attached? (Use pulldown)		Yes		
<small>If the trench has been designed correctly, there should be no error messages on the spreadsheet.</small>				
Notes:		Sediment Control via Filter Strip		
$V = d_w * A_d$ , $V = 6,263.2$ CF				

Infiltration Trench - Design Procedure		BMP ID	Legend:	Required Entries
		INF-4		Calculated Cells
Company Name:	Plump Engineering inc.		Date:	7/27/2022
Designed by:			County/City Case No.:	
<b>Design Volume</b>				
Enter the area tributary to this feature, Max = 10 acres			$A_t =$	0 acres
Enter $V_{BMP}$ determined from Section 2.1 of this Handbook			$V_{BMP} =$	693 $ft^3$
<b>Calculate Maximum Depth of the Reservoir Layer</b>				
Enter Infiltration rate			$I =$	1.6 in/hr
Enter Factor of Safety, FS (unitless)			$FS =$	3
<i>Obtain from Table 1, Appendix A: "Infiltration Testing" of this BMP Handbook</i>				
Calculate $D_1$ .			$D_1 =$	8.00 ft
$D_1 = \frac{I \text{ (in/hr)} \times 72 \text{ hrs}}{12 \text{ (in/ft)} \times (n/100) \times FS}$			$n =$	40 %
Enter depth to historic high groundwater mark (measured from finished grade)				20 ft
Enter depth to top of bedrock or impermeable layer (measured from finished grade)				15 ft
$D_2$ is the smaller of:				
Depth to groundwater - 11 ft; & Depth to impermeable layer - 6 ft			$D_2 =$	9.0 ft
$D_{MAX}$ is the smaller value of $D_1$ and $D_2$ , must be less than or equal to 8 feet.			$D_{MAX} =$	8.0 ft
<b>Trench Sizing</b>				
Enter proposed reservoir layer depth $D_R$ , must be $\leq D_{MAX}$			$D_R =$	7.00 ft
Calculate the design depth of water, $d_w$				
Design $d_w = (D_R) \times (n/100)$			Design $d_w =$	2.80 ft
Minimum Surface Area, $A_S$			$A_S =$	247 $ft^2$
			$A_S = \frac{V_{BMP}}{d_w}$	
Proposed Design Surface Area			$A_D =$	450 $ft^2$
Minimum Width = $D_R + 1$ foot pea gravel				8.00 ft
Sediment Control Provided? (Use pulldown)		Yes		
Geotechnical report attached? (Use pulldown)		Yes		
<small>If the trench has been designed correctly, there should be no error messages on the spreadsheet.</small>				
Notes:		Sediment Control via Filter Strip		
$V = d_w * A_d$ , $V = 1,260.3$ CF				



# Appendix 7: Hydromodification

*Supporting Detail Relating to Hydrologic Conditions of Concern*

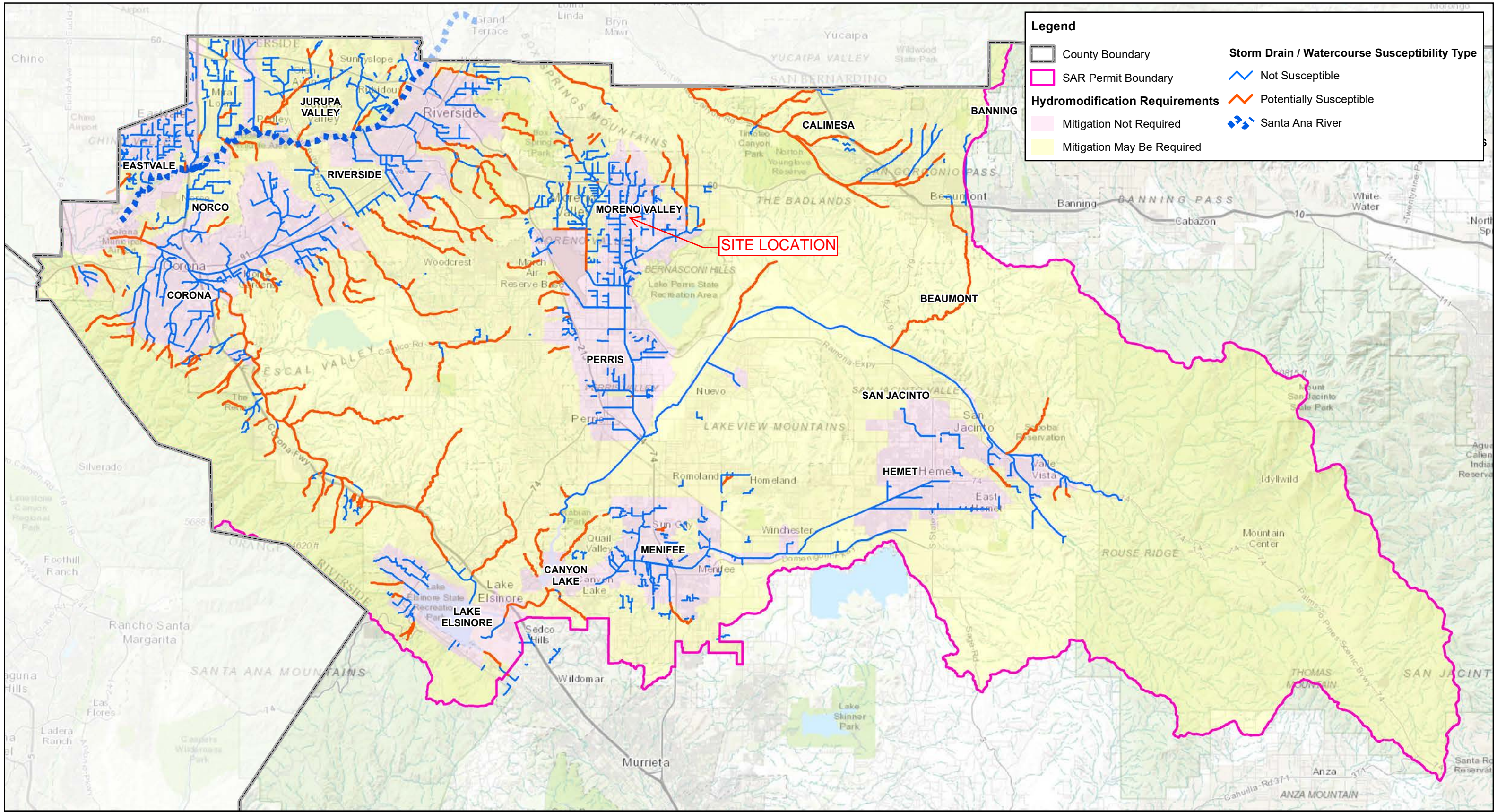

**Legend**

County Boundary	<b>Storm Drain / Watercourse Susceptibility Type</b>
SAR Permit Boundary	Not Susceptible
<b>Hydromodification Requirements</b>	Potentially Susceptible
Mitigation Not Required	Santa Ana River
Mitigation May Be Required	

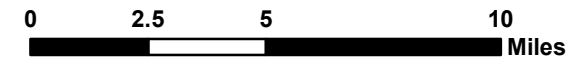

Updated February 2017

**HCOC Applicability Map  
SAR Permittees**

# Appendix 8: Source Control

*Pollutant Sources/Source Control Checklist*

STORMWATER POLLUTANT SOURCES/SOURCE CONTROL CHECKLIST

How to use this worksheet (also see instructions in Section G of the WQMP Template):

1. Review Column 1 and identify which of these potential sources of stormwater pollutants apply to your site. Check each box that applies.
2. Review Column 2 and incorporate all of the corresponding applicable BMPs in your WQMP Exhibit.
3. Review Columns 3 and 4 and incorporate all of the corresponding applicable permanent controls and operational BMPs in your WQMP. Use the format shown in Table G.1 on page 23 of this WQMP Template. Describe your specific BMPs in an accompanying narrative, and explain any special conditions or situations that required omitting BMPs or substituting alternative BMPs for those shown here.

IF THESE SOURCES WILL BE ON THE PROJECT SITE ...	... THEN YOUR WQMP SHOULD INCLUDE THESE SOURCE CONTROL BMPs, AS APPLICABLE		
1 Potential Sources of Runoff Pollutants	2 Permanent Controls—Show on WQMP Drawings	3 Permanent Controls—List in WQMP Table and Narrative	4 Operational BMPs—Include in WQMP Table and Narrative
<input checked="" type="checkbox"/> A. On-site storm drain inlets	<input checked="" type="checkbox"/> Locations of inlets.	<input checked="" type="checkbox"/> Mark all inlets with the words “Only Rain Down the Storm Drain” or similar. Catch Basin Markers may be available from the Riverside County Flood Control and Water Conservation District, call 951.955.1200 to verify.	<input checked="" type="checkbox"/> Maintain and periodically repaint or replace inlet markings. <input checked="" type="checkbox"/> Provide stormwater pollution prevention information to new site owners, lessees, or operators. <input checked="" type="checkbox"/> See applicable operational BMPs in Fact Sheet SC-44, “Drainage System Maintenance,” in the CASQA Stormwater Quality Handbooks at <a href="http://www.cabmphandbooks.com">www.cabmphandbooks.com</a> <input checked="" type="checkbox"/> Include the following in lease agreements: “Tenant shall not allow anyone to discharge anything to storm drains or to store or deposit materials so as to create a potential discharge to storm drains.”
<input type="checkbox"/> B. Interior floor drains and elevator shaft sump pumps		<input type="checkbox"/> State that interior floor drains and elevator shaft sump pumps will be plumbed to sanitary sewer.	<input type="checkbox"/> Inspect and maintain drains to prevent blockages and overflow.
<input type="checkbox"/> C. Interior parking garages		<input type="checkbox"/> State that parking garage floor drains will be plumbed to the sanitary sewer.	<input type="checkbox"/> Inspect and maintain drains to prevent blockages and overflow.

STORMWATER POLLUTANT SOURCES/SOURCE CONTROL CHECKLIST

IF THESE SOURCES WILL BE ON THE PROJECT SITE ...	... THEN YOUR WQMP SHOULD INCLUDE THESE SOURCE CONTROL BMPs, AS APPLICABLE		
1 Potential Sources of Runoff Pollutants	2 Permanent Controls—Show on WQMP Drawings	3 Permanent Controls—List in WQMP Table and Narrative	4 Operational BMPs—Include in WQMP Table and Narrative
<input type="checkbox"/> D1. Need for future indoor & structural pest control		<input type="checkbox"/> Note building design features that discourage entry of pests.	<input type="checkbox"/> Provide Integrated Pest Management information to owners, lessees, and operators.
<input checked="" type="checkbox"/> D2. Landscape/ Outdoor Pesticide Use	<input checked="" type="checkbox"/> Show locations of native trees or areas of shrubs and ground cover to be undisturbed and retained. <input checked="" type="checkbox"/> Show self-retaining landscape areas, if any. <input type="checkbox"/> Show stormwater treatment and hydrograph modification management BMPs. (See instructions in Chapter 3, Step 5 and guidance in Chapter 5.)	<p>State that final landscape plans will accomplish all of the following.</p> <input checked="" type="checkbox"/> Preserve existing native trees, shrubs, and ground cover to the maximum extent possible. <input checked="" type="checkbox"/> Design landscaping to minimize irrigation and runoff, to promote surface infiltration where appropriate, and to minimize the use of fertilizers and pesticides that can contribute to stormwater pollution. <input checked="" type="checkbox"/> Where landscaped areas are used to retain or detain stormwater, specify plants that are tolerant of saturated soil conditions. <input checked="" type="checkbox"/> Consider using pest-resistant plants, especially adjacent to hardscape. <p>To insure successful establishment, select plants appropriate to site soils, slopes, climate, sun, wind, rain, land use, air movement, ecological consistency, and plant interactions.</p>	<input checked="" type="checkbox"/> Maintain landscaping using minimum or no pesticides. <input checked="" type="checkbox"/> See applicable operational BMPs in “What you should know for.....Landscape and Gardening” at <a href="http://rcflood.org/stormwater/Error!">http://rcflood.org/stormwater/Error!</a> <small>Hyperlink reference not valid.</small> <input checked="" type="checkbox"/> Provide IPM information to new owners, lessees and operators.

STORMWATER POLLUTANT SOURCES/SOURCE CONTROL CHECKLIST

IF THESE SOURCES WILL BE ON THE PROJECT SITE ...	... THEN YOUR WQMP SHOULD INCLUDE THESE SOURCE CONTROL BMPs, AS APPLICABLE		
1 Potential Sources of Runoff Pollutants	2 Permanent Controls—Show on WQMP Drawings	3 Permanent Controls—List in WQMP Table and Narrative	4 Operational BMPs—Include in WQMP Table and Narrative
<input type="checkbox"/> E. Pools, spas, ponds, decorative fountains, and other water features.	<input type="checkbox"/> Show location of water feature and a sanitary sewer cleanout in an accessible area within 10 feet. (Exception: Public pools must be plumbed according to County Department of Environmental Health Guidelines.)	<p>If the Co-Permittee requires pools to be plumbed to the sanitary sewer, place a note on the plans and state in the narrative that this connection will be made according to local requirements.</p>	<input type="checkbox"/> See applicable operational BMPs in “Guidelines for Maintaining Your Swimming Pool, Jacuzzi and Garden Fountain” at <a href="http://rcflood.org/stormwater/">http://rcflood.org/stormwater/</a>
<input checked="" type="checkbox"/> F. Food service	<input checked="" type="checkbox"/> For restaurants, grocery stores, and other food service operations, show location (indoors or in a covered area outdoors) of a floor sink or other area for cleaning floor mats, containers, and equipment.  <input checked="" type="checkbox"/> On the drawing, show a note that this drain will be connected to a grease interceptor before discharging to the sanitary sewer.	<input checked="" type="checkbox"/> Describe the location and features of the designated cleaning area.  <input checked="" type="checkbox"/> Describe the items to be cleaned in this facility and how it has been sized to insure that the largest items can be accommodated.	<input checked="" type="checkbox"/> See the brochure, “The Food Service Industry Best Management Practices for: Restaurants, Grocery Stores, Delicatessens and Bakeries” at <a href="http://rcflood.org/stormwater/">http://rcflood.org/stormwater/</a>  <b>Provide this brochure to new site owners, lessees, and operators.</b>
<input checked="" type="checkbox"/> G. Refuse areas	<input checked="" type="checkbox"/> Show where site refuse and recycled materials will be handled and stored for pickup. See local municipal requirements for sizes and other details of refuse areas.  <input type="checkbox"/> If dumpsters or other receptacles are outdoors, show how the designated area will be covered, graded, and paved to prevent run-on and show locations of berms to prevent runoff from the area.  <input type="checkbox"/> Any drains from dumpsters, compactors, and tallow bin areas shall be connected to a grease removal device before discharge to sanitary sewer.	<input type="checkbox"/> State how site refuse will be handled and provide supporting detail to what is shown on plans.  <input type="checkbox"/> State that signs will be posted on or near dumpsters with the words “Do not dump hazardous materials here” or similar.	<input checked="" type="checkbox"/> State how the following will be implemented:  <b>Provide adequate number of receptacles. Inspect receptacles regularly; repair or replace leaky receptacles. Keep receptacles covered. Prohibit/prevent dumping of liquid or hazardous wastes. Post “no hazardous materials” signs. Inspect and pick up litter daily and clean up spills immediately. Keep spill control materials available on-site. See Fact Sheet SC-34, “Waste Handling and Disposal” in the CASQA Stormwater Quality Handbooks at <a href="http://www.cabmphandbooks.com">www.cabmphandbooks.com</a></b>

STORMWATER POLLUTANT SOURCES/SOURCE CONTROL CHECKLIST

IF THESE SOURCES WILL BE ON THE PROJECT SITE ...	... THEN YOUR WQMP SHOULD INCLUDE THESE SOURCE CONTROL BMPs, AS APPLICABLE		
1 Potential Sources of Runoff Pollutants	2 Permanent Controls—Show on WQMP Drawings	3 Permanent Controls—List in WQMP Table and Narrative	4 Operational BMPs—Include in WQMP Table and Narrative
<input type="checkbox"/> H. Industrial processes.	<input type="checkbox"/> Show process area.	<input type="checkbox"/> If industrial processes are to be located on site, state: “All process activities to be performed indoors. No processes to drain to exterior or to storm drain system.”	<input type="checkbox"/> See Fact Sheet SC-10, “Non-Stormwater Discharges” in the CASQA Stormwater Quality Handbooks at <a href="http://www.cabmphandbooks.com">www.cabmphandbooks.com</a>  See the brochure “Industrial & Commercial Facilities Best Management Practices for: Industrial, Commercial Facilities” at <a href="http://rcflood.org/stormwater/">http://rcflood.org/stormwater/</a>

STORMWATER POLLUTANT SOURCES/SOURCE CONTROL CHECKLIST

IF THESE SOURCES WILL BE ON THE PROJECT SITE ...	... THEN YOUR WQMP SHOULD INCLUDE THESE SOURCE CONTROL BMPs, AS APPLICABLE		
1 Potential Sources of Runoff Pollutants	2 Permanent Controls—Show on WQMP Drawings	3 Permanent Controls—List in WQMP Table and Narrative	4 Operational BMPs—Include in WQMP Table and Narrative
<p><input type="checkbox"/> I. Outdoor storage of equipment or materials. (See rows J and K for source control measures for vehicle cleaning, repair, and maintenance.)</p>	<p><input type="checkbox"/> Show any outdoor storage areas, including how materials will be covered. Show how areas will be graded and bermed to prevent run-on or run-off from area.</p> <p><input type="checkbox"/> Storage of non-hazardous liquids shall be covered by a roof and/or drain to the sanitary sewer system, and be contained by berms, dikes, liners, or vaults.</p> <p><input type="checkbox"/> Storage of hazardous materials and wastes must be in compliance with the local hazardous materials ordinance and a Hazardous Materials Management Plan for the site.</p>	<p>Include a detailed description of materials to be stored, storage areas, and structural features to prevent pollutants from entering storm drains.</p> <p>Where appropriate, reference documentation of compliance with the requirements of Hazardous Materials Programs for:</p> <ul style="list-style-type: none"> <li>▪ Hazardous Waste Generation</li> <li>▪ Hazardous Materials Release Response and Inventory</li> <li>▪ California Accidental Release (CalARP)</li> <li>▪ Aboveground Storage Tank</li> <li>▪ Uniform Fire Code Article 80 Section 103(b) &amp; (c) 1991</li> <li>▪ Underground Storage Tank</li> </ul> <p><a href="http://www.cchealth.org/groups/hazmat/">www.cchealth.org/groups/hazmat/</a></p>	<p><input type="checkbox"/> See the Fact Sheets SC-31, “Outdoor Liquid Container Storage” and SC-33, “Outdoor Storage of Raw Materials ” in the CASQA Stormwater Quality Handbooks at <a href="http://www.cabmphandbooks.com">www.cabmphandbooks.com</a></p>



STORMWATER POLLUTANT SOURCES/SOURCE CONTROL CHECKLIST

IF THESE SOURCES WILL BE ON THE PROJECT SITE ...	... THEN YOUR WQMP SHOULD INCLUDE THESE SOURCE CONTROL BMPs, AS APPLICABLE		
1 Potential Sources of Runoff Pollutants	2 Permanent Controls—Show on WQMP Drawings	3 Permanent Controls—List in WQMP Table and Narrative	4 Operational BMPs—Include in WQMP Table and Narrative
<p><input type="checkbox"/> <b>J. Vehicle and Equipment Cleaning</b></p>	<p><input type="checkbox"/> <b>Show on drawings as appropriate:</b></p> <p>(1) Commercial/industrial facilities having vehicle/equipment cleaning needs shall either provide a covered, bermed area for washing activities or discourage vehicle/equipment washing by removing hose bibs and installing signs prohibiting such uses.</p> <p>(2) Multi-dwelling complexes shall have a paved, bermed, and covered car wash area (unless car washing is prohibited on-site and hoses are provided with an automatic shut-off to discourage such use).</p> <p>(3) Washing areas for cars, vehicles, and equipment shall be paved, designed to prevent run-on to or runoff from the area, and plumbed to drain to the sanitary sewer.</p> <p>(4) Commercial car wash facilities shall be designed such that no runoff from the facility is discharged to the storm drain system. Wastewater from the facility shall discharge to the sanitary sewer, or a wastewater reclamation system shall be installed.</p>	<p><input type="checkbox"/> <b>If a car wash area is not provided, describe any measures taken to discourage on-site car washing and explain how these will be enforced.</b></p>	<p><b>Describe operational measures to implement the following (if applicable):</b></p> <p><input type="checkbox"/> <b>Washwater from vehicle and equipment washing operations shall not be discharged to the storm drain system.</b> Refer to “Outdoor Cleaning Activities and Professional Mobile Service Providers” for many of the Potential Sources of Runoff Pollutants categories below. Brochure can be found at <a href="http://rcflood.org/stormwater/">http://rcflood.org/stormwater/</a></p> <p><input type="checkbox"/> <b>Car dealerships and similar may rinse cars with water only.</b></p>

STORMWATER POLLUTANT SOURCES/SOURCE CONTROL CHECKLIST

IF THESE SOURCES WILL BE ON THE PROJECT SITE ...	... THEN YOUR WQMP SHOULD INCLUDE THESE SOURCE CONTROL BMPs, AS APPLICABLE		
1 Potential Sources of Runoff Pollutants	2 Permanent Controls—Show on WQMP Drawings	3 Permanent Controls—List in WQMP Table and Narrative	4 Operational BMPs—Include in WQMP Table and Narrative
<p><input type="checkbox"/> <b>K. Vehicle/Equipment Repair and Maintenance</b></p>	<p><input type="checkbox"/> Accommodate all vehicle equipment repair and maintenance indoors. Or designate an outdoor work area and design the area to prevent run-on and runoff of stormwater.</p> <p><input type="checkbox"/> Show secondary containment for exterior work areas where motor oil, brake fluid, gasoline, diesel fuel, radiator fluid, acid-containing batteries or other hazardous materials or hazardous wastes are used or stored. Drains shall not be installed within the secondary containment areas.</p> <p><input type="checkbox"/> Add a note on the plans that states either (1) there are no floor drains, or (2) floor drains are connected to wastewater pretreatment systems prior to discharge to the sanitary sewer and an industrial waste discharge permit will be obtained.</p>	<p><input type="checkbox"/> State that no vehicle repair or maintenance will be done outdoors, or else describe the required features of the outdoor work area.</p> <p><input type="checkbox"/> State that there are no floor drains or if there are floor drains, note the agency from which an industrial waste discharge permit will be obtained and that the design meets that agency’s requirements.</p> <p><input type="checkbox"/> State that there are no tanks, containers or sinks to be used for parts cleaning or rinsing or, if there are, note the agency from which an industrial waste discharge permit will be obtained and that the design meets that agency’s requirements.</p>	<p>In the Stormwater Control Plan, note that all of the following restrictions apply to use the site:</p> <p><input type="checkbox"/> No person shall dispose of, nor permit the disposal, directly or indirectly of vehicle fluids, hazardous materials, or rinsewater from parts cleaning into storm drains.</p> <p><input type="checkbox"/> No vehicle fluid removal shall be performed outside a building, nor on asphalt or ground surfaces, whether inside or outside a building, except in such a manner as to ensure that any spilled fluid will be in an area of secondary containment. Leaking vehicle fluids shall be contained or drained from the vehicle immediately.</p> <p><input type="checkbox"/> No person shall leave unattended drip parts or other open containers containing vehicle fluid, unless such containers are in use or in an area of secondary containment.</p> <p>Refer to “Automotive Maintenance &amp; Car Care Best Management Practices for Auto Body Shops, Auto Repair Shops, Car Dealerships, Gas Stations and Fleet Service Operations”. Brochure can be found at <a href="http://rcflood.org/stormwater/">http://rcflood.org/stormwater/</a></p> <p>Refer to Outdoor Cleaning Activities and Professional Mobile Service Providers for many of the Potential Sources of Runoff Pollutants categories below. Brochure can be found at <a href="http://rcflood.org/stormwater/">http://rcflood.org/stormwater/</a></p>

STORMWATER POLLUTANT SOURCES/SOURCE CONTROL CHECKLIST

IF THESE SOURCES WILL BE ON THE PROJECT SITE ...	... THEN YOUR WQMP SHOULD INCLUDE THESE SOURCE CONTROL BMPs, AS APPLICABLE		
1 Potential Sources of Runoff Pollutants	2 Permanent Controls—Show on WQMP Drawings	3 Permanent Controls—List in WQMP Table and Narrative	4 Operational BMPs—Include in WQMP Table and Narrative
<input type="checkbox"/> L. Fuel Dispensing Areas	<input type="checkbox"/> Fueling areas <sup>6</sup> shall have impermeable floors (i.e., portland cement concrete or equivalent smooth impervious surface) that are: a) graded at the minimum slope necessary to prevent ponding; and b) separated from the rest of the site by a grade break that prevents run-on of stormwater to the maximum extent practicable.  <input type="checkbox"/> Fueling areas shall be covered by a canopy that extends a minimum of ten feet in each direction from each pump. [Alternative: The fueling area must be covered and the cover's minimum dimensions must be equal to or greater than the area within the grade break or fuel dispensing area <sup>1</sup> .] The canopy [or cover] shall not drain onto the fueling area.		<input type="checkbox"/> The property owner shall dry sweep the fueling area routinely. <input type="checkbox"/> See the Fact Sheet SD-30 , “Fueling Areas” in the CASQA Stormwater Quality Handbooks at <a href="http://www.cabmphandbooks.com">www.cabmphandbooks.com</a>

---

<sup>6</sup> The fueling area shall be defined as the area extending a minimum of 6.5 feet from the corner of each fuel dispenser or the length at which the hose and nozzle assembly may be operated plus a minimum of one foot, whichever is greater.



STORMWATER POLLUTANT SOURCES/SOURCE CONTROL CHECKLIST

IF THESE SOURCES WILL BE ON THE PROJECT SITE ...	... THEN YOUR WQMP SHOULD INCLUDE THESE SOURCE CONTROL BMPs, AS APPLICABLE		
1 Potential Sources of Runoff Pollutants	2 Permanent Controls—Show on WQMP Drawings	3 Permanent Controls—List in WQMP Table and Narrative	4 Operational BMPs—Include in WQMP Table and Narrative
<input type="checkbox"/> M. Loading Docks	<input type="checkbox"/> Show a preliminary design for the loading dock area, including roofing and drainage. Loading docks shall be covered and/or graded to minimize run-on to and runoff from the loading area. Roof downspouts shall be positioned to direct stormwater away from the loading area. Water from loading dock areas shall be drained to the sanitary sewer, or diverted and collected for ultimate discharge to the sanitary sewer.  <input type="checkbox"/> Loading dock areas draining directly to the sanitary sewer shall be equipped with a spill control valve or equivalent device, which shall be kept closed during periods of operation.  <input type="checkbox"/> Provide a roof overhang over the loading area or install door skirts (cowling) at each bay that enclose the end of the trailer.		<input type="checkbox"/> Move loaded and unloaded items indoors as soon as possible.  <input type="checkbox"/> See Fact Sheet SC-30, “Outdoor Loading and Unloading,” in the CASQA Stormwater Quality Handbooks at <a href="http://www.cabmphandbooks.com">www.cabmphandbooks.com</a>

STORMWATER POLLUTANT SOURCES/SOURCE CONTROL CHECKLIST

IF THESE SOURCES WILL BE ON THE PROJECT SITE ...	... THEN YOUR WQMP SHOULD INCLUDE THESE SOURCE CONTROL BMPs, AS APPLICABLE		
1 Potential Sources of Runoff Pollutants	2 Permanent Controls—Show on WQMP Drawings	3 Permanent Controls—List in WQMP Table and Narrative	4 Operational BMPs—Include in WQMP Table and Narrative
<input type="checkbox"/> N. Fire Sprinkler Test Water		<input type="checkbox"/> Provide a means to drain fire sprinkler test water to the sanitary sewer.	<input type="checkbox"/> See the note in Fact Sheet SC-41, “Building and Grounds Maintenance,” in the CASQA Stormwater Quality Handbooks at <a href="http://www.cabmphandbooks.com">www.cabmphandbooks.com</a>
<p>O. Miscellaneous Drain or Wash Water or Other Sources</p> <input type="checkbox"/> Boiler drain lines <input type="checkbox"/> Condensate drain lines <input type="checkbox"/> Rooftop equipment <input type="checkbox"/> Drainage sumps <input type="checkbox"/> Roofing, gutters, and trim. <input type="checkbox"/> Other sources		<input type="checkbox"/> Boiler drain lines shall be directly or indirectly connected to the sanitary sewer system and may not discharge to the storm drain system. <input type="checkbox"/> Condensate drain lines may discharge to landscaped areas if the flow is small enough that runoff will not occur. Condensate drain lines may not discharge to the storm drain system. Rooftop equipment with potential to produce pollutants shall be roofed and/or have secondary containment. <input type="checkbox"/> Any drainage sumps on-site shall feature a sediment sump to reduce the quantity of sediment in pumped water. <input checked="" type="checkbox"/> Avoid roofing, gutters, and trim made of copper or other unprotected metals that may leach into runoff. Include controls for other sources as specified by local reviewer.	

STORMWATER POLLUTANT SOURCES/SOURCE CONTROL CHECKLIST

IF THESE SOURCES WILL BE ON THE PROJECT SITE ...	... THEN YOUR WQMP SHOULD INCLUDE THESE SOURCE CONTROL BMPs, AS APPLICABLE		
1 Potential Sources of Runoff Pollutants	2 Permanent Controls—Show on WQMP Drawings	3 Permanent Controls—List in WQMP Table and Narrative	4 Operational BMPs—Include in WQMP Table and Narrative
 P. Plazas, sidewalks, and parking lots.			 Sweep plazas, sidewalks, and parking lots regularly to prevent accumulation of litter and debris. Collect debris from pressure washing to prevent entry into the storm drain system. Collect washwater containing any cleaning agent or degreaser and discharge to the sanitary sewer not to a storm drain.

## Appendix 9: O&M

*Operation and Maintenance Plan and Documentation of Finance, Maintenance and Recording Mechanisms*

**Moreno Valley Commercial Center**  
**Nwc Alessandro Blvd. & Lasselle St., Moreno Valley, Ca 92553**



**REQUIRED PERMITS**

This section must list any permits required for the implementation, operation, and maintenance of the BMPs. Possible examples are:

- Permits for connection to sanitary sewer
- Permits from California Department of Fish and Game
- Encroachment permits

If no permits are required, a statement to that effect should be made.

**RECORDKEEPING**

All records must be made available for review upon request.

**RESPONSIBLE PARTY**

The owner is aware of the maintenance responsibilities of the proposed BMPs. A funding mechanism is in place to maintain the BMPs at the frequency stated in the LID Plan. The contact information for the entity responsible is below:

Name:	Danny Singh
Company:	
Title:	Owner
Address 1:	3017 E. Edinger Ave.
Address 2:	Tustin, CA 92780
Phone Number:	(949) 630-5345
Email:	dannysingh9@gmail.com

BMP Name	BMP Implementation, Maintenance, and Inspection Procedures	Implementation, Maintenance, and Inspection Frequency and Schedule	Person or Entity with Operation & Maintenance Responsibility
Non-Structural Source Control BMPs			
<p>Education for Property Owners, Tenants and Occupants</p>	<p><b>For developments with no Property Owners Association (POA) or with POAs of less than fifty (50) dwelling units, practical information materials will be provided to the first residents/occupants/tenants on general housekeeping practices that contribute to the protection of stormwater quality. These materials will be initially developed and provided to first residents/occupants/tenants by the developer. Thereafter such materials will be available through the Permittees' education program. Different materials for residential, office commercial, retail commercial, vehicle-related commercial and industrial uses will be developed.</b></p> <p><b>Brief employee with the maintenance and monitoring of all BMPs.</b></p> <p><b>Orientation and training shall be provided to new owners, employees, tenants and contractors.</b></p>	<p><b>Ongoing.</b></p>	<p><b>Responsible Party:</b>  <b>Danny Singh</b>  <b>3017 E. Edinger Ave.</b>  <b>Tustin, CA 92780</b>  <b>(949) 630-5345</b>  <b>dannysingh9@gmail.com</b></p>

BMP Name	BMP Implementation, Maintenance, and Inspection Procedures	Implementation, Maintenance, and Inspection Frequency and Schedule	Person or Entity with Operation & Maintenance Responsibility
Activity Restriction	<p><b>If a POA is formed, conditions, covenants and restrictions (CCRs) must be prepared by the developer for the purpose of surface water quality protection. An example would be not allowing car washing outside of established community car wash areas in multi-unit complexes. Alternatively, use restrictions may be developed by a building operator through lease terms, etc. These restrictions must be included in the Project SUSMP Report.</b></p> <p>Prohibit maintenance &amp; washing of vehicles, outdoor storage of materials, unlabeled containers, loading/unloading of materials that may come in contact with stormwater.</p>	<p><b>Orientation and training shall be provided to new owners, employees, tenants and contractors.</b></p> <p><b>Ongoing.</b></p>	<p><b>Responsible Party: Danny Singh 3017 E. Edinger Ave. Tustin, CA 92780 (949) 630-5345 dannysingh9@gmail.com</b></p>
Common Area Landscape Management	<p><b>Identify on-going landscape maintenance requirements that are consistent with those in the County Water Conservation Resolution (or city equivalent) that include fertilizer and/or pesticide usage consistent with Management Guidelines for Use of Fertilizers.</b></p> <p><b>Remove dead leaves, tree trunks, etc. Remove and replace plants that are showing signs of dying.</b></p>	<p><b>Inspect and maintain landscape areas on regular basis.</b></p>	<p><b>Responsible Party: Danny Singh 3017 E. Edinger Ave. Tustin, CA 92780 (949) 630-5345 dannysingh9@gmail.com</b></p>

BMP Name	BMP Implementation, Maintenance, and Inspection Procedures	Implementation, Maintenance, and Inspection Frequency and Schedule	Person or Entity with Operation & Maintenance Responsibility
Common Area Litter Control	<p><b>For industrial/commercial developments and for developments with POAs, the owner/POA should be required to implement trash management and litter control procedures in the common areas aimed at reducing pollution of drainage water. The owner/POA may contract with their landscape maintenance firms to provide this service during regularly scheduled maintenance, which should consist of litter patrol, emptying of trash receptacles in common areas, and noting trash disposal violations by tenants/homeowners or businesses and reporting the violations to the owner/POA for investigation.</b></p>	<p><b>Provide this service during regularly scheduled maintenance, which should consist of litter patrol, emptying of trash receptacles in common areas, and noting trash disposal violations.</b></p> <p><b>Every two weeks.</b></p>	<p><b>Responsible Party: Danny Singh 3017 E. Edinger Ave. Tustin, CA 92780 (949) 630-5345 dannysingh9@gmail.com</b></p>
BMP Maintenance	<p><b>The Project SUSMP shall identify responsibility for implementation of each non-structural BMP and scheduled cleaning and/or maintenance of all structural BMP facilities.</b></p> <p><b>Identify responsibility for implementation of each non-structural BMP and scheduled cleaning and/or maintenance of all structural BMP facilities.</b></p>	<p><b>Ongoing.</b></p>	<p><b>Responsible Party: Danny Singh 3017 E. Edinger Ave. Tustin, CA 92780 (949) 630-5345 dannysingh9@gmail.com</b></p>

BMP Name	BMP Implementation, Maintenance, and Inspection Procedures	Implementation, Maintenance, and Inspection Frequency and Schedule	Person or Entity with Operation & Maintenance Responsibility
Uniform Fire Code Implementation	<p><b>Compliance with Article 80 of the Uniform Fire Code enforced by fire protection agency.</b></p> <p>Facility shall be in compliance with Article 80 of the Uniform Fire Code enforced by fire protection agency. The classification of hazards for chemicals stored, used, and handled at this facility is required to ensure that proper types of fire and life safety protection systems and procedures are in place at all times.</p>	<p><b>Orientation and training shall be provided to new owners, employees, tenants and contractors about flammable materials and products.</b></p> <p>Ongoing.</p>	<p><b>Responsible Party:</b>  <b>Danny Singh</b>  <b>3017 E. Edinger Ave.</b>  <b>Tustin, CA 92780</b>  <b>(949) 630-5345</b>  <b>dannysingh9@gmail.com</b></p>
Common Area Litter Control	<p><b>For industrial/commercial developments and for developments with POAs, the owner/POA should be required to implement trash management and litter control procedures in the common areas aimed at reducing pollution of drainage water. The owner/POA may contract with their landscape maintenance firms to provide this service during regularly scheduled maintenance, which should consist of litter patrol, emptying of trash receptacles in common areas, and noting trash disposal violations by tenants/homeowners or businesses and reporting the violations to the owner/POA for investigation.</b></p>	<p><b>Provide this service during regularly scheduled maintenance, which should consist of litter patrol, emptying of trash receptacles in common areas, and noting trash disposal violations.</b></p> <p>Every two weeks.</p>	<p><b>Responsible Party:</b>  <b>Danny Singh</b>  <b>3017 E. Edinger Ave.</b>  <b>Tustin, CA 92780</b>  <b>(949) 630-5345</b>  <b>dannysingh9@gmail.com</b></p>

BMP Name	BMP Implementation, Maintenance, and Inspection Procedures	Implementation, Maintenance, and Inspection Frequency and Schedule	Person or Entity with Operation & Maintenance Responsibility
Employee Training	<p><b>Education program (see N1) as it would apply to future employees of individual businesses. Developer either prepares manual(s) for initial purchasers of business site or for development that is constructed for an unspecified use makes commitment on behalf of POA or future business owner to prepare. An example would be training on the proper storage and use of fertilizers and pesticides, or training on the implementation of hazardous spill contingency plans.</b></p> <p><b>Train all employees, management, office, yard, manufacturing, field and clerical in BMPs and pollution prevention and make them aware of the maintenance procedures and requirements of all BMPs.</b></p>	<p><b>Orientation and training shall be provided to new owners, employees, tenants and contractors.</b></p> <p><b>Within 6 months after occupancy and annually thereafter.</b></p>	<p><b>Responsible Party: Danny Singh 3017 E. Edinger Ave. Tustin, CA 92780 (949) 630-5345 dannysingh9@gmail.com</b></p>

BMP Name	BMP Implementation, Maintenance, and Inspection Procedures	Implementation, Maintenance, and Inspection Frequency and Schedule	Person or Entity with Operation & Maintenance Responsibility
Common Area Catch Basin Inspection	<p><b>For industrial/commercial developments and for developments with privately maintained drainage systems, the owner is required to have at least 80 percent of drainage facilities inspected, cleaned and maintained on an annual basis with 100 percent of the facilities included in a two-year period. Cleaning should take place in the late summer/early fall prior to the start of the rainy season. Drainage facilities include catch basins (storm drain inlets) detention basins, retention basins, sediment basins, open drainage channels and lift stations. Records should be kept to document the annual maintenance.</b></p>	<p><b>Inspect annually, clean at minimum, prior to October 1<sup>st</sup> or more often as needed when debris is present.</b></p> <p><b>All drainage facilities inspected, cleaned and maintained after every storm events. Remove debris and garbage to avoid clogging of the storm drain system.</b></p>	<p><b>Responsible Party: Danny Singh 3017 E. Edinger Ave. Tustin, CA 92780 (949) 630-5345 dannysingh9@gmail.com</b></p>
Street Sweeping Private Streets and Parking Lots	<p><b>Streets and parking lots are required to be swept prior to the storm season, in late summer or early fall, prior to the start of the rainy season or equivalent as required by the governing jurisdiction. Prevent soil from being washed onto pavement and keep landscape areas well maintained. Vacuum/Pressure- wash clogged surfaces. Clean and remove trash, debris and washed out soil from the pavement surface and along gutter flow lines.</b></p>	<p><b>Every two weeks and once before October 1<sup>st</sup>.</b></p>	<p><b>Responsible Party: Danny Singh 3017 E. Edinger Ave. Tustin, CA 92780 (949) 630-5345 dannysingh9@gmail.com</b></p>

BMP Name	BMP Implementation, Maintenance, and Inspection Procedures	Implementation, Maintenance, and Inspection Frequency and Schedule	Person or Entity with Operation & Maintenance Responsibility
Non-Storm Water Discharges	<b>Train employees to identify non-stormwater discharges and report them to appropriate departments.</b>	<b>Nuisance water and spills to be removed on regular basis. No standing water is allowed in more than 48 hrs.</b>  <b>Daily or as needed.</b>	<b>Responsible Party: Danny Singh 3017 E. Edinger Ave. Tustin, CA 92780 (949) 630-5345 dannysingh9@gmail.com</b>
Waste Handling & Disposal	<b>Post “No Littering” signs and enforce anti-litter laws. Keep waste collection areas clean.</b>	<b>Daily or as needed.</b>	<b>Responsible Party: Danny Singh 3017 E. Edinger Ave. Tustin, CA 92780 (949) 630-5345 dannysingh9@gmail.com</b>
Building & Grounds Maintenance	<b>Prevent soil from being washed onto pavement and keep landscape areas well maintained inspect pavement at least twice per year. Inspect outlets annually. Vacuum/Pressure wash clogged surfaces.</b>	<b>Weekly or as needed.</b>	<b>Responsible Party: Danny Singh 3017 E. Edinger Ave. Tustin, CA 92780 (949) 630-5345 dannysingh9@gmail.com</b>
Parking/Storage Area Maintenance	<b>Keep parking and storage areas clean and orderly. Remove debris in a timely fashion. Have designated personnel conduct inspections of the parking facilities and stormwater conveyance systems associated with them on a regular basis.</b>	<b>Weekly or as needed.</b>	<b>Responsible Party: Danny Singh 3017 E. Edinger Ave. Tustin, CA 92780 (949) 630-5345 dannysingh9@gmail.com</b>



BMP Name	BMP Implementation, Maintenance, and Inspection Procedures	Implementation, Maintenance, and Inspection Frequency and Schedule	Person or Entity with Operation & Maintenance Responsibility
Drainage System Maintenance	<b>Staff regularly inspect facilities to ensure compliance with standard practices for immediate repair of drainage devices. Check legibility of stencils and signs.</b>	<b>At least three times per year or as needed.</b>	<b>Responsible Party: Danny Singh 3017 E. Edinger Ave. Tustin, CA 92780 (949) 630-5345 dannysingh9@gmail.com</b>
Housekeeping Practices	<b>Keep work sites clean and orderly. Remove debris in a timely fashion. Sweep the area on regular basis.</b>	<b>Daily or as needed.</b>	<b>Responsible Party: Danny Singh 3017 E. Edinger Ave. Tustin, CA 92780 (949) 630-5345 dannysingh9@gmail.com</b>
Provide Storm Drain System Stenciling and Signage	<b>Post signs, with language and/or graphical icons that prohibit illegal dumping, at designated public access points along channels and streams within the project area. Storm drain message markers, concrete stamps, or stenciling language/icons are required at all storm drain inlets and catch basins within project area. Maintain legibility and visibility of markers by repainting or replacing as necessary.</b>	<b>As needed.</b>	<b>Responsible Party: Danny Singh 3017 E. Edinger Ave. Tustin, CA 92780 (949) 630-5345 dannysingh9@gmail.com</b>

BMP Name	BMP Implementation, Maintenance, and Inspection Procedures	Implementation, Maintenance, and Inspection Frequency and Schedule	Person or Entity with Operation & Maintenance Responsibility
Use Efficient Irrigation Systems & Landscape Design	<b>Equipment-water sensors, irrigation heads and timing-inspection on a monthly basis.</b>	<b>Monthly basis.</b>	<b>Responsible Party: Danny Singh 3017 E. Edinger Ave. Tustin, CA 92780 (949) 630-5345 dannysingh9@gmail.com</b>
Treatment Control BMPs			
Infiltration Trench TC-10	<b>Maintain adjacent landscape areas. Remove clippings from landscape maintenance activities. Remove trash and debris. Check for surface ponding. If ponding is only above the trench, remove, wash and replace pea gravel.</b>	<b>As Needed and a3 days after a major storm event.</b>	<b>Responsible Party: Danny Singh 3017 E. Edinger Ave. Tustin, CA 92780 (949) 630-5345 dannysingh9@gmail.com</b>

# Appendix 10: Educational Materials

*BMP Fact Sheets, Maintenance Guidelines and Other End-User BMP Information*



# A Citizen's Guide to Understanding Stormwater



EPA  
United States Environmental Protection Agency

EPA 833-B-03-002

January 2003

Internet Address (URL) • HTTP://www.epa.gov  
Oil Based Inks on 100% Postconsumer  
Recycled/Recyclable • Printed With Vegetable  
Process Chlorine Free Recycled Paper



## After the Storm

For more information contact:  
[www.epa.gov/nps/stormwater](http://www.epa.gov/nps/stormwater)  
or visit  
[www.epa.gov/nps](http://www.epa.gov/nps)



### What is stormwater runoff?

Stormwater runoff occurs when precipitation from rain or snowmelt flows over the ground. Impervious surfaces like driveways, sidewalks, and streets prevent stormwater from naturally soaking into the ground.

### Why is stormwater runoff a problem?

Stormwater can pick up debris, chemicals, dirt, and other pollutants and flow into a storm sewer system or directly to a lake, stream, river, wetland, or coastal water. Anything that enters a storm sewer system is discharged untreated into the waterbodies we use for swimming, fishing, and providing drinking water.

### The effects of pollution

Polluted stormwater runoff can have many adverse effects on plants, fish, animals, and people.

- ◆ Sediment can cloud the water and make it difficult or impossible for aquatic plants to grow. Sediment also can destroy aquatic habitats.
- ◆ Excess nutrients can cause algae blooms. When algae die, they sink to the bottom and decompose in a process that removes oxygen from the water. Fish and other aquatic organisms can't exist in water with low dissolved oxygen levels.
- ◆ Bacteria and other pathogens can wash into swimming areas and create health hazards, often making beach closures necessary.
- ◆ Debris—plastic bags, six-pack rings, bottles, and cigarette butts—washed into waterbodies can choke, suffocate, or disable aquatic life like ducks, fish, turtles, and birds.
- ◆ Household hazardous wastes like insecticides, pesticides, paint, solvents, used motor oil, and other auto fluids can poison aquatic life. Land animals and people can become sick or die from eating diseased fish and shellfish or ingesting polluted water.

◆ Polluted stormwater often affects drinking water sources. This, in turn, can affect human health and increase drinking water treatment costs.



# Stormwater Pollution Solutions

## Residential

Recycle or properly dispose of household products that contain chemicals, such as insecticides, pesticides, paint, solvents, and used motor oil and other auto fluids. Don't pour them onto the ground or into storm drains.

### Lawn care

Excess fertilizers and pesticides applied to lawns and gardens wash off and pollute streams. In addition, yard clippings and leaves can wash into storm drains and contribute nutrients and organic matter to streams.



- ◆ Don't overwater your lawn. Consider using a soaker hose instead of a sprinkler.
- ◆ Use pesticides and fertilizers sparingly. When use is necessary, use these chemicals in the recommended amounts. Use organic mulch or safer pest control methods whenever possible.
- ◆ Compost or mulch yard waste. Don't leave it in the street or sweep it into storm drains or streams.
- ◆ Cover piles of dirt or mulch being used in landscaping projects.

### Septic systems

Leaking and poorly maintained septic systems release nutrients and pathogens (bacteria and viruses) that can be picked up by stormwater and discharged into nearby waterbodies. Pathogens can cause public health problems and environmental concerns.



- ◆ Inspect your system every 3 years and pump your tank as necessary (every 3 to 5 years).
- ◆ Don't dispose of household hazardous waste in sinks or toilets.

### Auto care

Washing your car and degreasing auto parts at home can send detergents and other contaminants through the storm sewer system. Dumping automotive fluids into storm drains has the same result as dumping the materials directly into a waterbody.



- ◆ Use a commercial car wash that treats or recycles its wastewater, or wash your car on your yard so the water infiltrates into the ground.
- ◆ Repair leaks and dispose of used auto fluids and batteries at designated drop-off or recycling locations.

### Pet waste

Pet waste can be a major source of bacteria and excess nutrients in local waters.



- ◆ When walking your pet, remember to pick up the waste and dispose of it properly. Flushing pet waste is the best disposal method. Leaving pet waste on the ground increases public health risks by allowing harmful bacteria and nutrients to wash into the storm drain and eventually into local waterbodies.

## Residential landscaping

**Permeable Pavement**—Traditional concrete and asphalt don't allow water to soak into the ground. Instead these surfaces rely on storm drains to divert unwanted water. Permeable pavement systems allow rain and snowmelt to soak through, decreasing stormwater runoff.

**Rain Barrels**—You can collect rainwater from rooftops in mosquito-proof containers. The water can be used later on lawn or garden areas.



**Rain Gardens and Grassy Swales**—Specially designed areas planted with native plants can provide natural places for



rainwater to collect and soak into the ground. Rain from rooftop areas or paved areas can be diverted into these areas rather than into storm drains.

**Vegetated Filter Strips**—Filter strips are areas of native grass or plants created along roadways or streams. They trap the pollutants stormwater picks up as it flows across driveways and streets.

## Commercial

Dirt, oil, and debris that collect in parking lots and paved areas can be washed into the storm sewer system and eventually enter local waterbodies.

- ◆ Sweep up litter and debris from sidewalks, driveways and parking lots, especially around storm drains.
- ◆ Cover grease storage and dumpsters and keep them clean to avoid leaks.
- ◆ Report any chemical spill to the local hazardous waste cleanup team. They'll know the best way to keep spills from harming the environment.

Erosion controls that aren't maintained can cause excessive amounts of sediment and debris to be carried into the stormwater system. Construction vehicles can leak fuel, oil, and other harmful fluids that can be picked up by stormwater and deposited into local waterbodies.

- ◆ Divert stormwater away from disturbed or exposed areas of the construction site.
- ◆ Install silt fences, vehicle mud removal areas, vegetative cover, and other sediment and erosion controls and properly maintain them, especially after rainstorms.
- ◆ Prevent soil erosion by minimizing disturbed areas during construction projects, and seed and mulch bare areas as soon as possible.

## Construction

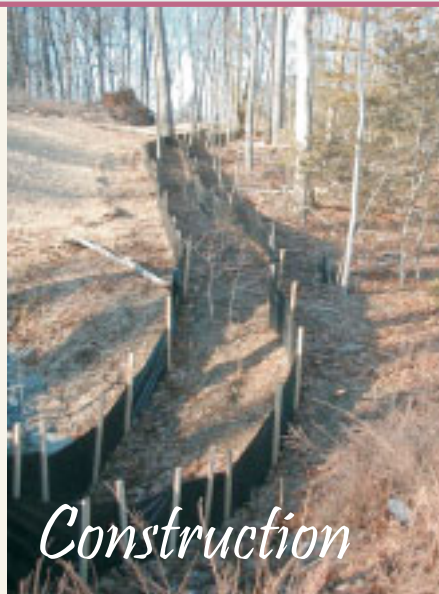

## Agriculture

Lack of vegetation on streambanks can lead to erosion. Overgrazed pastures can also contribute excessive amounts of sediment to local waterbodies. Excess fertilizers and pesticides can poison aquatic animals and lead to destructive algae blooms. Livestock in streams can contaminate waterways with bacteria, making them unsafe for human contact.

- ◆ Keep livestock away from streambanks and provide them a water source away from waterbodies.
- ◆ Store and apply manure away from waterbodies and in accordance with a nutrient management plan.
- ◆ Vegetate riparian areas along waterways.
- ◆ Rotate animal grazing to prevent soil erosion in fields.
- ◆ Apply fertilizers and pesticides according to label instructions to save money and minimize pollution.



## Forestry

Improperly managed logging operations can result in erosion and sedimentation.

- ◆ Conduct preharvest planning to prevent erosion and lower costs.
- ◆ Use logging methods and equipment that minimize soil disturbance.
- ◆ Plan and design skid trails, yard areas, and truck access roads to minimize stream crossings and avoid disturbing the forest floor.
- ◆ Construct stream crossings so that they minimize erosion and physical changes to streams.
- ◆ Expedite revegetation of cleared areas.

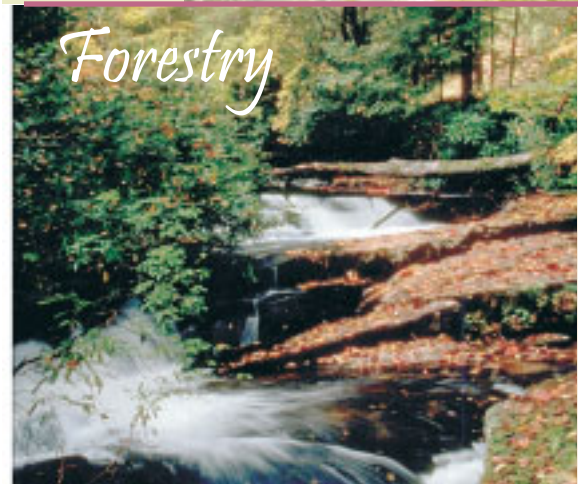

## Automotive Facilities

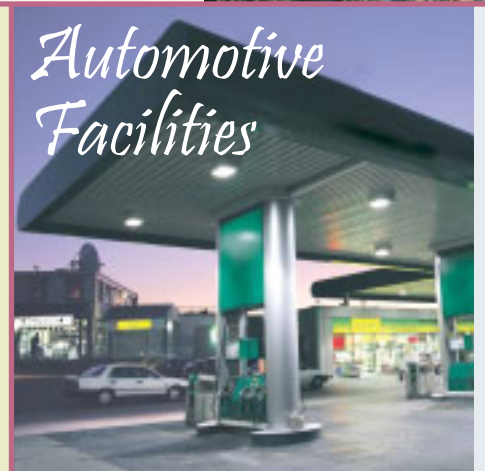

Uncovered fueling stations allow spills to be washed into storm drains. Cars waiting to be repaired can leak fuel, oil, and other harmful fluids that can be picked up by stormwater.

- ◆ Clean up spills immediately and properly dispose of cleanup materials.
- ◆ Provide cover over fueling stations and design or retrofit facilities for spill containment.
- ◆ Properly maintain fleet vehicles to prevent oil, gas, and other discharges from being washed into local waterbodies.
- ◆ Install and maintain oil/water separators.



## 3.2 INFILTRATION TRENCH

Type of BMP	LID - Infiltration
Treatment Mechanisms	Infiltration, Evapotranspiration (when vegetated), Evaporation
Maximum Drainage Area	10-acres
Other Names	None

### Description

Infiltration trenches are shallow excavated areas that are filled with rock material to create a subsurface reservoir layer. The trench is sized to store the design capture volume,  $V_{BMP}$ , in the void space between the rocks. Over a period of 72 hours, the stormwater infiltrates through the bottom of the trench into the surrounding soil. Infiltration basins are highly effective in removing all targeted pollutants from stormwater runoff.

Figure 1 shows the components of an infiltration trench. The section shows the reservoir layer and observation well, which is used to monitor water depth. An overflow pipe that is used to bypass flows once the trench fills with stormwater is also shown.

### Site Considerations

#### **Location**

The use of infiltration trenches may be restricted by concerns over groundwater contamination, soil permeability, and clogging at the site. See the applicable WQMP for any specific feasibility considerations for using infiltration BMPs. Where this BMP is being used, the soil beneath the basin must be thoroughly evaluated in a geotechnical report since the underlying soils are critical to the basin's long term performance. These basins may not be appropriate for the following site conditions:

- Industrial sites or locations where spills of toxic materials may occur.
- Sites with very low soil infiltration rates.
- Sites with high groundwater tables or excessively high soil infiltration rates, where pollutants can affect groundwater quality.
- Sites with unstabilized soil or construction activity upstream.
- On steeply sloping terrain.
- Infiltration trenches located in a fill condition should refer to Appendix A of this Handbook for details on special requirements/restrictions.

This BMP has a flat surface area, so it may be challenging to incorporate into steeply sloping terrain.

## INFILTRATION TRENCH BMP FACT SHEET

### Setbacks

Always consult your geotechnical engineer for site specific recommendations regarding setbacks for infiltration trenches. Recommended setbacks are needed to protect buildings, walls, onsite or nearby wells, streams, and tanks. Setbacks should be considered early in the design process as they affect where infiltration facilities may be placed and how deep they are allowed to be. For instance, depth setbacks can dictate fairly shallow facilities that will have a larger footprint and, in some cases, may make an infiltration trench infeasible. In that instance, another BMP must be selected.

In addition to setbacks recommended by the geotechnical engineer, infiltration trenches must be set back:

- 10 feet from the historic high groundwater mark (measured vertically from the bottom of the trench, as shown in Figure 1)
- 5 feet from bedrock or impermeable surface layer (measured vertically from the bottom of the trench, as shown in Figure 1)
- From all mature tree drip lines as indicated in Figure 1
- 100 feet horizontally from wells, tanks or springs

Setbacks to walls and foundations must be included as part of the Geotechnical Report.

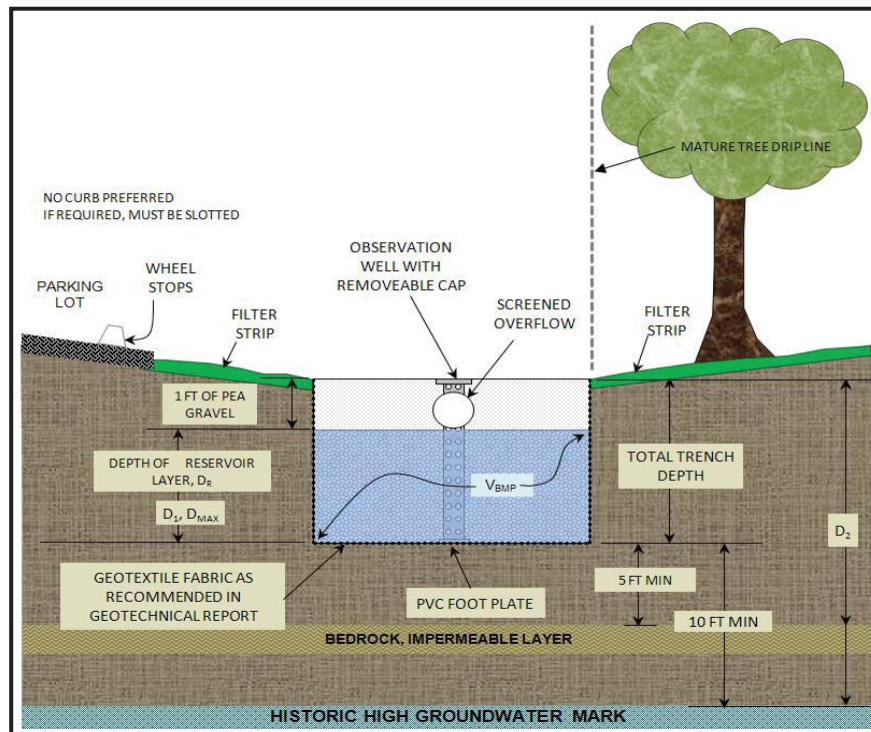

**Figure 1** Section View of an Infiltration Trench

## INFILTRATION TRENCH BMP FACT SHEET

### Sediment Control

Infiltration BMPs have the risk of becoming plugged over time. To prevent this, sediment must be removed before stormwater enters the trench. Both sheet and concentrated flow types have requirements that should be considered in the design of an infiltration trench.

When sheet type flows approach the trench along its length (as illustrated in Figure 2), a vegetated filter strip should be placed between the trench

and the upstream drainage area. The filter strip must be a minimum of 5 feet wide and planted with grasses (preferably native) or covered with mulch.

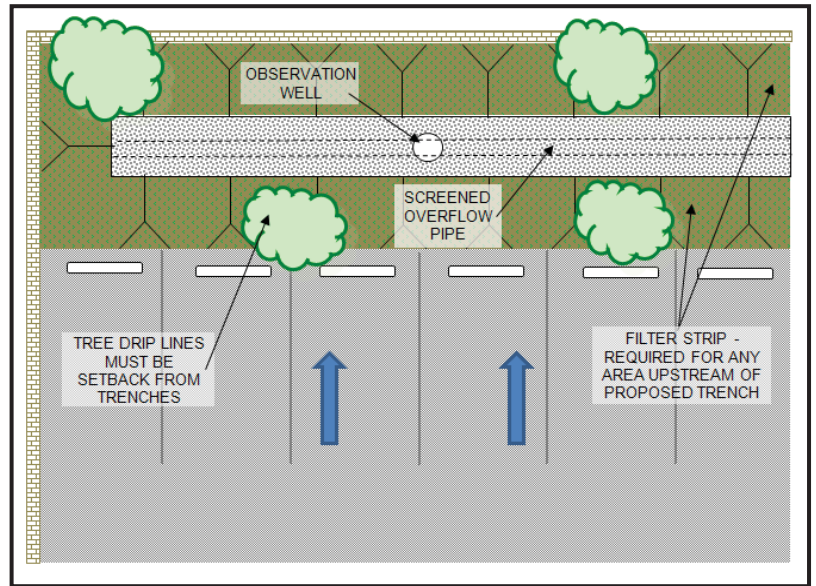

**Figure 2** Plan View, Sheet Type Flows

Concentrated flows require a different approach. A 2004 Caltrans BMP Retrofit Report found that flow spreaders recommended in many water quality manuals are ineffective in distributing concentrated flows. As such, concentrated flows should either be directed toward a traditional vegetated swale (as shown on the right side of Figure 3) or to catch basin filters that can remove litter and sediment. Catch basins must discharge runoff as surface flow above the trench; they cannot outlet directly into the reservoir layer of the infiltration trench. If catch basins are used, the short and long term costs of the catch basin filters should be considered.

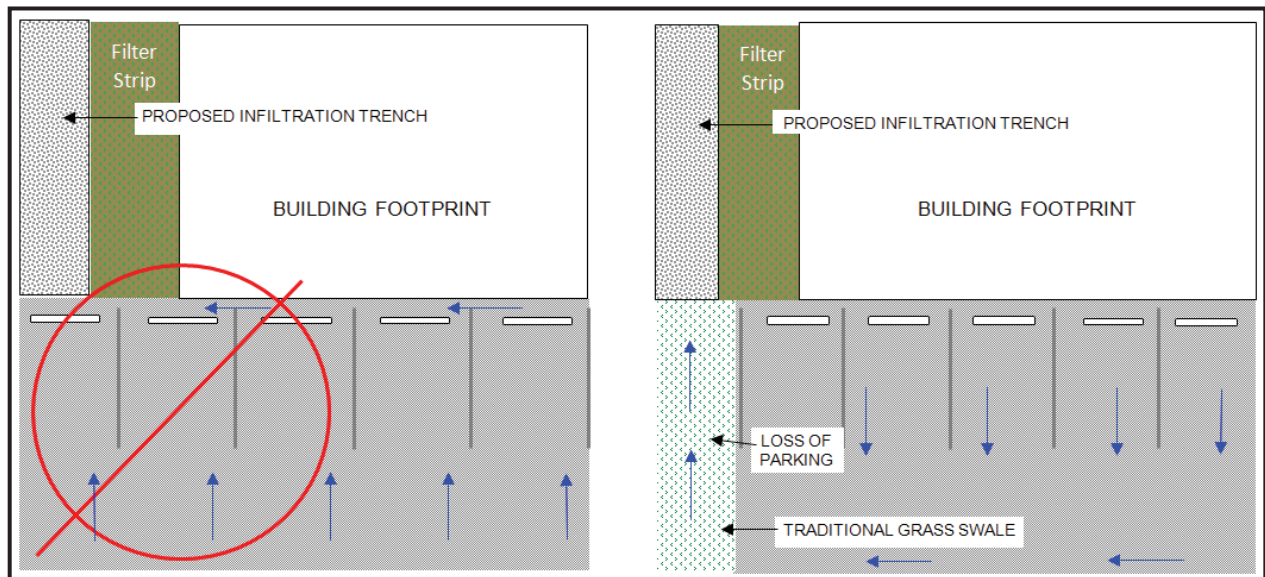

**Figure 3** Plan View, Concentrated Flows



# INFILTRATION TRENCH BMP FACT SHEET

## **Additional Considerations**

### **Class V Status**

In certain circumstances, for example, if an infiltration trench is “deeper than its widest surface dimension,” or includes an assemblage of perforated pipes, drain tiles, or other similar mechanisms intended to distribute fluids below the surface of the ground, it would probably be considered by the EPA to be a Class V injection well. Class V injection wells are subject to regulations and reporting requirements via the Underground Injection Control (UIC) Program. To ensure that infiltration trenches are not considered Class V wells, the design procedure in this manual requires that the trench not be deeper than it is wide.

### **Geotechnical Report**

A geotechnical report must be included for all infiltration trenches. Appendix A of this Handbook entitled “Infiltration Testing Guidelines”, details which types of infiltration tests are acceptable and how many tests or boring logs must be performed. A Geotechnical Report must be submitted in support of all infiltration trenches. Setbacks to walls and foundations must be included in the Geotechnical Report.

### **Observation Wells**

One or more observation wells should be provided. The observation well consists of a vertical section of perforated pipe, 4 to 6 inches in diameter, installed flush with top of trench on a foot plate and have a locking, removable cap.

### **Overflow**

An overflow route is needed to bypass storm flows larger than the  $V_{BMP}$  or in the event of clogging. Overflow systems must connect to an acceptable discharge point such as a downstream conveyance system.

### **Maintenance Access**

Normal maintenance of an infiltration trench includes maintenance of the filter strip as well as debris and trash removal from the surface of the trench and filter strip. More substantial maintenance requiring vehicle access may be required every 5 to 10 years. Vehicular access along the length of the swale should be provided to all infiltration trenches. It is preferred that trenches be placed longitudinally along a street or adjacent to a parking lot area. These conditions have high visibility which makes it more likely that the trench will be maintained on a regular basis.

## INFILTRATION TRENCH BMP FACT SHEET

### Inspection and Maintenance

Schedule	Inspection and Maintenance Activity
Every two weeks, or as often as necessary to maintain a pleasant appearance	<ul style="list-style-type: none"> <li>- Maintain adjacent landscaped areas. Remove clippings from landscape maintenance activities.</li> <li>- Remove trash &amp; debris</li> </ul>
3 days after Major Storm Events	<ul style="list-style-type: none"> <li>- Check for surface ponding. If ponding is only above the trench, remove, wash and replace pea gravel. May be needed every 5-10 years.</li> <li>- Check observation well for ponding. If the trench becomes plugged, remove rock materials. Provide a fresh infiltration surface by excavating an additional 2-4 inches of soil. Replace the rock materials.</li> </ul>

### Design and Sizing Criteria

Design Parameter	Design Criteria
Design Volume	$V_{BMP}$
Design Drawdown time	72 hrs
Maximum Tributary Drainage Area	10 acres
Maximum Trench Depth	8.0 ft
Width to Depth Ratio	Width must be greater than depth
Reservoir Rock Material	AASHTO #3 or 57 material or a clean, washed aggregate 1 to 3-in diameter equivalent
Filter Strip Width	Minimum of 5 feet in the direction of flow for all areas draining to trench
Filter Strip Slope	Max slope = 1%
Filter Strip Materials	Mulch or grasses (non-mowed variety preferred)
Historic High Groundwater Mark	10 ft or more below bottom of trench
Bedrock/Impermeable Layer Setback	5 ft or more below bottom of trench
Tree Setbacks	Mature tree drip line must not overhang the trench
Trench Lining Material	As recommended in Geotechnical Report

## INFILTRATION TRENCH BMP FACT SHEET

### Infiltration Trench Design Procedure

1. Enter the area tributary to the trench, maximum drainage area is 10 acres.
2. Enter the Design Volume,  $V_{BMP}$ , determined from Section 2.1 of this Handbook.
3. Enter the site infiltration rate, found in the geotechnical report.
4. Enter the factor of safety from Table 1 of Appendix A, Infiltration Testing.
5. Determine the maximum reservoir layer depth,  $D_{MAX}$ . The value is obtained by taking the smaller of two depth equations but may never exceed 8 feet. The first depth,  $D_1$  is related to the infiltration rate of the soil. The second depth,  $D_2$ , is related to required setbacks to groundwater, bedrock/impermeable layer. These parameters are shown in Figure 1.

Calculate  $D_1$ .

$$D_1 = \frac{I \left( \frac{\text{in}}{\text{hr}} \right) \times 72 \text{ (hrs)}}{12 \left( \frac{\text{in}}{\text{ft}} \right) \times n/100 \times FS}$$

Where:

- I = site infiltration rate (in/hr), found in the geotechnical report
- FS = factor of safety, refer to Appendix A - Infiltration Testing
- n = porosity of the trench material, 40%

Calculate  $D_2$ . Enter the depth to the seasonal high groundwater and bedrock/impermeable layer measured from the finished grade. The spreadsheet checks the minimum setbacks shown in Figure 1 and selects the smallest value. The equations are listed below for those doing hand calculations.

Minimum Setbacks (includes 1 foot for pea gravel):

- = Depth to historic high groundwater mark - 11 feet
- = Depth to impermeable layer - 6 feet

$D_2$  is the smaller of the two values.

$D_{MAX}$  is the smaller value of  $D_1$  and  $D_2$ , and must be less than or equal to 8 feet.

6. Enter the proposed reservoir layer depth,  $D_R$ . The value must be no greater than  $D_{MAX}$ .

## INFILTRATION TRENCH BMP FACT SHEET

7. Find the required surface area of the trench,  $A_S$ . Once  $D_R$  is entered, the spreadsheet will calculate the corresponding depth of water and the minimum surface area of the trench.

$$\text{Design } d_W = D_R \times (n/100) \qquad A_S = \frac{V_{BMP}}{\text{Design } d_W}$$

Where:

$A_S$  = minimum area required (ft<sup>2</sup>)

$V_{BMP}$  = BMP storage volume (ft<sup>3</sup>)

Design  $d_W$  = Depth of water in reservoir layer (ft)

8. Enter the proposed design surface area; it must be greater than the minimum surface area.
9. Calculate the minimum trench width. This is to ensure that EPA's Class V Injection well status is not triggered. The total trench depth (shown in Figure 1) includes the upper foot where the overflow pipe is located. The minimum surface dimension is  $D_R + 1$  foot.

### Additional Items

The following items detailed in the preceding sections should also be addressed in the design.

- Sediment Control
- Geotechnical Report
- Observation well(s)
- Overflow

## INFILTRATION TRENCH BMP FACT SHEET

### Reference Material

California Stormwater Quality Association. California Stormwater BMP Handbook New Development and Redevelopment. 2003.

County of Los Angeles Department of Public Works. Stormwater BMP Best Management Practice Design and Maintenance Manual for Publicly Maintained Storm Drain Systems. Los Angeles, CA, 2009.

LandSaver Stormwater Management System. Tech Sheet - Porosity of Structural Backfill. 2006.

United States Environmental Protection Agency. Office of Water, Washington D.C. Storm Water Technology Fact Sheet Vegetated Swales. 1999.

United States Environmental Protection Agency. Office of Water. Memorandum on Clarification on Which Stormwater Infiltration Practices/technologies Have the Potential to Be Regulated as "Class V" Wells by Underground Injection Control Program. By Linda Boornazian and Steve Heare. Washington D.C., 2008.

Ventura Countywide Stormwater Quality Management Program. Land Development Guidelines Biofilter Fact Sheet. Ventura, CA, 2001.

Ventura Countywide Stormwater Quality Management Program. Technical Guidance Manual for Stormwater Quality Control Measures. Ventura, CA, 2002.



---

## Objectives

---

- Cover
- Contain
- Educate
- Reduce/Minimize

---

## Targeted Constituents

---

Sediment	
Nutrients	
Trash	✓
Metals	✓
Bacteria	
Oil and Grease	✓
Organics	✓
Oxygen Demanding	

---

### Description

Spills and leaks that occur during vehicle and equipment fueling can contribute hydrocarbons, oil and grease, as well as heavy metals to stormwater runoff. Implementing the following management practices can help prevent fuel spills and leaks.

### Approach

Reduce potential for pollutant discharge through source control pollution prevention and BMP implementation. Successful implementation depends on effective training of employees on applicable BMPs and general pollution prevention strategies and objectives.

### Pollution Prevention

- Use properly maintained offsite fueling stations whenever possible. These businesses are better equipped to handle fuel and spills properly.
- Educate employees about pollution prevention measures and goals
- Focus pollution prevention activities on containment of spills and leaks, most of which may occur during liquid transfers.

### Suggested Protocols

#### General

- "Spot clean" leaks and drips routinely. Leaks are not cleaned up until the absorbent is picked up and disposed of properly.



- Label drains within the facility boundary, by paint/stencil (or equivalent), to indicate whether they flow to an oil/water separator, directly to the sewer, or to a storm drain. Labels are not necessary for plumbing fixtures directly connected to the sanitary sewer but may be useful to help eliminate confusion about where the drain leads.
- Post signs to remind employees not to top off the fuel tank when filling and signs that ban employees from changing engine oil or other fluids at that location.
- Report leaking vehicles to fleet maintenance.
- Install inlet catch basin equipped with a small sedimentation basin or grit chamber to remove large particles from stormwater in highly impervious areas. Proper maintenance of these devices is necessary.
- Accumulated non-contaminated stormwater (e.g., in a secondary containment) should be released prior to next storm.
- Ensure the following safeguards are in place:
  - Overflow protection devices on tank systems to warn the operator to automatically shutdown transfer pumps when the tank reaches full capacity.
  - Protective guards around tanks and piping to prevent vehicle or forklift damage.
  - Clearly tagging or labeling all valves to reduce human error.
  - Automatic shut off for severed fuel hoses.

#### *Fuel Dispensing Areas*

- Maintain clean fuel-dispensing areas using dry cleanup methods such as sweeping for removal of litter and debris, or use of rags and absorbents for leaks and spills. Do not wash down areas with water.
- Fit underground storage tanks with spill containment and overfill prevention systems meeting the requirements of Section 2635(b) of Title 23 of the California Code of Regulations.
- Fit fuel dispensing nozzles with "hold-open latches" (automatic shutoffs) except where prohibited by local fire departments.
- Post signs at the fuel dispenser or fuel island warning vehicle owners/operators against "topping off" of vehicle fuel tanks.
- Design fueling area to prevent stormwater runoff and spills.
- Cover fueling area with an overhanging roof structure or canopy so that precipitation cannot come in contact with the fueling area and if possible use a perimeter drain or slope pavement inward with drainage to a blind sump (must be properly maintained and water properly disposed of); pave area with concrete rather than asphalt.

- Apply a suitable sealant that protects the asphalt from spilled fuels in areas where covering is infeasible and the fuel island is surrounded by pavement.
- Install vapor recovery nozzles to help control drips as well as air pollution.
- Use secondary containment when transferring fuel from the tank truck to the fuel tank.
- Cover storm drains in the vicinity during transfer.

## *Outdoor Waste Receptacle Area*

- Spot clean leaks and drips routinely to prevent runoff of spillage.
- Minimize the possibility of stormwater pollution from outside waste receptacles by using an effective combination of the following:
  - use only watertight waste receptacle(s) and keep the lid(s) closed, or
  - grade and pave the waste receptacle area to prevent runoff of stormwater, or
  - install a roof over the waste receptacle area, or
  - install a low containment berm around the waste receptacle area, or
  - use and maintain drip pans under waste receptacles. Containment areas and drip pans must be properly maintained and collected water disposed of properly (e.g., to sanitary sewer). Several drip pans should be stored in a covered location near outdoor waste receptacle area so that they are always available, yet protected from precipitation when not in use.
- Post “no littering” signs.

## *Air/Water Supply Area*

- Minimize the possibility of stormwater pollution from air/water supply areas by implementing an effective combination of the following:
  - spot clean leaks and drips routinely to prevent runoff of spillage, or
  - grade and pave the air/water supply area to prevent runoff of stormwater, or
  - install a roof over the air/water supply area, or
  - install a low containment berm around the air/water supply area. Maintain containment areas and dispose of contaminated water properly (e.g., to sanitary sewer).

## *Inspection*

- Aboveground Tank Leak and Spill Control:
  - Check for external corrosion and structural failure.



- Check for spills and overfills due to operator error.
  - Check for failure of piping system.
  - Check for leaks or spills during pumping of liquids or gases from truck or rail car to a storage facility or vice versa.
  - Visually inspect new tank or container installation for loose fittings, poor welding, and improper or poorly fitted gaskets.
  - Inspect tank foundations, connections, coatings, and tank walls and piping system. Look for corrosion, leaks, cracks, scratches, and other physical damage that may weaken the tank or container system.
  - Periodically, integrity testing should be conducted by a qualified professional.
- Inspect and clean, if necessary, storm drain inlets and catch basins within the facility boundary before October 1 each year.

### ***Training***

- Train all employees upon hiring and annually thereafter on proper methods for handling and disposing of waste. Make sure that all employees understand stormwater discharge prohibitions, wastewater discharge requirements, and these best management practices.
- Train employees on proper fueling and cleanup procedures.
- Use a training log or similar method to document training.
- Ensure that employees are familiar with the site's spill control plan and/or proper spill cleanup procedures.

### ***Spill Response and Prevention***

- Keep your Spill Prevention Control and Countermeasure (SPCC) Plan up-to-date.
- Place stockpiles of spill cleanup materials where they are readily accessible.
- Use adsorbent materials on small spills and general cleaning rather than hosing down the area. Remove the adsorbent materials promptly and dispose properly.
- Store portable absorbent booms (long flexible shafts or barriers made of absorbent material) in unbermed fueling areas.
- Report spills promptly.
- Install an oil/water separator and connect to the sanitary sewer (if allowed), if a dead-end sump is not used to collect spills.

### ***Other Considerations***

- Carry out all federal and state requirements regarding underground storage tanks, or install above ground tanks.

## Requirements

### *Costs*

- The retrofitting of existing fueling areas to minimize stormwater exposure or spill runoff can be expensive. Good design must occur during the initial installation.
- Extruded curb along the “upstream” side of the fueling area to prevent stormwater runoff is of modest cost.

### *Maintenance*

- Clean oil/water separators at appropriate intervals.
- Keep ample supplies of spill cleanup materials onsite.
- Inspect fueling areas, storage tanks, catch basin inserts, containment areas, and drip pans on a regular schedule.

## Supplemental Information

### *Design Considerations*

#### *Designing New Installations*

The elements listed below should be included in the design and construction of new or substantially remodeled facilities.

#### Fuel Dispensing Areas

- Fuel dispensing areas must be paved with Portland cement concrete (or, equivalent smooth impervious surface), with a 2% to 4% slope to prevent ponding, and must be separated from the rest of the site by a grade break that prevents runoff of stormwater to the extent practicable. The fuel dispensing area is defined as extending 6.5 feet from the corner of each fuel dispenser or the length at which the hose and nozzle assembly may be operated plus 1 foot, whichever is less. The paving around the fuel dispensing area may exceed the minimum dimensions of the "fuel dispensing area" stated above.
- The fuel dispensing area must be covered, and the cover's minimum dimensions must be equal to or greater than the area within the grade break or the fuel dispensing area, as defined above. The cover must not drain onto the fuel dispensing area.
- If necessary install and maintain an oil control device in the appropriate catch basin(s) to treat runoff from the fueling area.

#### Outdoor Waste Receptacle Area

- Grade and pave the outdoor waste receptacle area to prevent runoff of stormwater to the extent practicable.

#### Air/Water Supply Area

- Grade and pave the air/water supply area to prevent runoff of stormwater to the extent practicable.

# SC-20      Vehicle and Equipment Fueling

---

## *Designated Fueling Area*

- If your facility has large numbers of mobile equipment working throughout the site and you currently fuel them with a mobile fuel truck, consider establishing a designated fueling area. With the exception of tracked equipment such as bulldozers and perhaps small forklifts, most vehicles should be able to travel to a designated area with little lost time. Place temporary “caps” over nearby catch basins or manhole covers so that if a spill occurs it is prevented from entering the storm drain.

## *Examples*

The Spill Prevention Control and Countermeasure (SPCC) Plan, which is required by law for some facilities, is an effective program to reduce the number of accidental spills and minimize contamination of stormwater runoff.

The City of Palo Alto has an effective program for commercial vehicle service facilities. Many of the program’s elements, including specific BMP guidance and lists of equipment suppliers, are also applicable to industrial facilities.

## **References and Resources**

Best Management Practice Guide for Retail Gasoline Outlets, California Stormwater Quality Task Force. 1997.

King County Stormwater Pollution Control Manual –  
<http://www.dnr.metrokc.gov/wlr/dss/spcm.htm>

Orange County Stormwater Program  
[http://www.ocwatersheds.com/StormWater/swp\\_introduction.asp](http://www.ocwatersheds.com/StormWater/swp_introduction.asp)

San Diego Stormwater Co-permittees Jurisdictional Urban Runoff Management Program (URMP)



## Objectives

- Cover
- Contain
- Educate
- Reduce/Minimize
- Product Substitution

## Description

Improper storage and handling of solid wastes can allow toxic compounds, oils and greases, heavy metals, nutrients, suspended solids, and other pollutants to enter stormwater runoff. The discharge of pollutants to stormwater from waste handling and disposal can be prevented and reduced by tracking waste generation, storage, and disposal; reducing waste generation and disposal through source reduction, re-use, and recycling; and preventing runoff and runoff.

## Approach

### *Pollution Prevention*

- Reduction in the amount of waste generated can be accomplished using the following source controls such as:
  - Production planning and sequencing
  - Process or equipment modification
  - Raw material substitution or elimination
  - Loss prevention and housekeeping
  - Waste segregation and separation
  - Close loop recycling
- Establish a material tracking system to increase awareness about material usage. This may reduce spills and minimize contamination, thus reducing the amount of waste produced.
- Recycle materials whenever possible.

## Targeted Constituents

Sediment	<input checked="" type="checkbox"/>
Nutrients	<input checked="" type="checkbox"/>
Trash	<input checked="" type="checkbox"/>
Metals	<input checked="" type="checkbox"/>
Bacteria	<input checked="" type="checkbox"/>
Oil and Grease	<input checked="" type="checkbox"/>
Organics	<input checked="" type="checkbox"/>
Oxygen Demanding	<input checked="" type="checkbox"/>



***Suggested Protocols******General***

- Cover storage containers with leak proof lids or some other means. If waste is not in containers, cover all waste piles (plastic tarps are acceptable coverage) and prevent stormwater runoff and runoff with a berm. The waste containers or piles must be covered except when in use.
- Use drip pans or absorbent materials whenever grease containers are emptied by vacuum trucks or other means. Grease cannot be left on the ground. Collected grease must be properly disposed of as garbage.
- Check storage containers weekly for leaks and to ensure that lids are on tightly. Replace any that are leaking, corroded, or otherwise deteriorating.
- Sweep and clean the storage area regularly. If it is paved, do not hose down the area to a storm drain.
- Dispose of rinse and wash water from cleaning waste containers into a sanitary sewer if allowed by the local sewer authority. Do not discharge wash water to the street or storm drain.
- Transfer waste from damaged containers into safe containers.
- Take special care when loading or unloading wastes to minimize losses. Loading systems can be used to minimize spills and fugitive emission losses such as dust or mist. Vacuum transfer systems can minimize waste loss.

***Controlling Litter***

- Post “No Littering” signs and enforce anti-litter laws.
- Provide a sufficient number of litter receptacles for the facility.
- Clean out and cover litter receptacles frequently to prevent spillage.

***Waste Collection***

- Keep waste collection areas clean.
- Inspect solid waste containers for structural damage or leaks regularly. Repair or replace damaged containers as necessary.
- Secure solid waste containers; containers must be closed tightly when not in use.
- Place waste containers under cover if possible.
- Do not fill waste containers with washout water or any other liquid.
- Ensure that only appropriate solid wastes are added to the solid waste container. Certain wastes such as hazardous wastes, appliances, fluorescent lamps, pesticides, etc. may not be

disposed of in solid waste containers (see chemical/ hazardous waste collection section below).

- Do not mix wastes; this can cause chemical reactions, make recycling impossible, and complicate disposal.

## ***Good Housekeeping***

- Use all of the product before disposing of the container.
- Keep the waste management area clean at all times by sweeping and cleaning up spills immediately.
- Use dry methods when possible (e.g. sweeping, use of absorbents) when cleaning around restaurant/food handling dumpster areas. If water must be used after sweeping/using absorbents, collect water and discharge through grease interceptor to the sewer.
- Stencil storm drains on the facility's property with prohibitive message regarding waste disposal.

## ***Chemical/Hazardous Wastes***

- Select designated hazardous waste collection areas on-site.
- Store hazardous materials and wastes in covered containers protected from vandalism, and in compliance with fire and hazardous waste codes.
- Place hazardous waste containers in secondary containment.
- Make sure that hazardous waste is collected, removed, and disposed of only at authorized disposal areas.

## ***Runon/Runoff Prevention***

- Prevent stormwater runon from entering the waste management area by enclosing the area or building a berm around the area.
- Prevent the waste materials from directly contacting rain.
- Cover waste piles with temporary covering material such as reinforced tarpaulin, polyethylene, polyurethane, polypropylene or hypalon.
- Cover the area with a permanent roof if feasible.
- Cover dumpsters to prevent rain from washing waste out of holes or cracks in the bottom of the dumpster.
- Move the activity indoor after ensuring all safety concerns such as fire hazard and ventilation are addressed.

## ***Inspection***

- Inspect and replace faulty pumps or hoses regularly to minimize the potential of releases and spills.
- Check waste management areas for leaking containers or spills.
- Repair leaking equipment including valves, lines, seals, or pumps promptly.

***Training***

- Train staff pollution prevention measures and proper disposal methods.
- Train employees and contractors proper spill containment and cleanup. The employee should have the tools and knowledge to immediately begin cleaning up a spill if one should occur.
- Train employees and subcontractors in proper hazardous waste management.

***Spill Response and Prevention***

- Refer to SC-11, Spill Prevention, Control & Cleanup.
- Keep your Spill Prevention Control and countermeasure (SPCC) plan up-to-date, and implement accordingly.
- Have spill cleanup materials readily available and in a known location.
- Cleanup spills immediately and use dry methods if possible.
- Properly dispose of spill cleanup material.
- Vehicles transporting waste should have spill prevention equipment that can prevent spills during transport. The spill prevention equipment includes:
  - Vehicles equipped with baffles for liquid waste
  - Trucks with sealed gates and spill guards for solid waste

***Other Considerations***

- Hazardous waste cannot be re-used or recycled; it must be disposed of by a licensed hazardous waste hauler.

**Requirements*****Costs***

- Capital and operation and maintenance costs will vary substantially depending on the size of the facility and the types of waste handled. Costs should be low if there is an inventory program in place.

***Maintenance***

- None except for maintaining equipment for material tracking program.

## Supplemental Information

### *Further Detail of the BMP*

#### *Land Treatment System*

- Minimize the runoff of polluted stormwater from land application of municipal waste on-site by:
  - Choosing a site where slopes are under 6%, the soil is permeable, there is a low water table, it is located away from wetlands or marshes, there is a closed drainage system.
  - Avoiding application of waste to the site when it is raining or when the ground is saturated with water.
  - Growing vegetation on land disposal areas to stabilize soils and reduce the volume of surface water runoff from the site.
  - Maintaining adequate barriers between the land application site and the receiving waters. Planted strips are particularly good.
  - Using erosion control techniques such as mulching and matting, filter fences, straw bales, diversion terracing, and sediment basins.
  - Performing routine maintenance to ensure the erosion control or site stabilization measures are working.

## References and Resources

King County Stormwater Pollution Control Manual - <http://dnr.metrokc.gov/wlr/dss/spcm.htm>

Orange County Stormwater Program

[http://www.ocwatersheds.com/StormWater/swp\\_introduction.asp](http://www.ocwatersheds.com/StormWater/swp_introduction.asp)

Pollution from Surface Cleaning Folder. 1996. Bay Area Stormwater Management Agencies Associations (BASMAA). On-line: <http://www.basmaa.org>





## Description

Stormwater runoff from building and grounds maintenance activities can be contaminated with toxic hydrocarbons in solvents, fertilizers and pesticides, suspended solids, heavy metals, and abnormal pH. Utilizing the following protocols will prevent or reduce the discharge of pollutants to stormwater from building and grounds maintenance activities by washing and cleaning up with as little water as possible, following good landscape management practices, preventing and cleaning up spills immediately, keeping debris from entering the storm drains, and maintaining the stormwater collection system.

## Approach

### *Pollution Prevention*

- Switch to non-toxic chemicals for maintenance when possible.
- Choose cleaning agents that can be recycled.
- Encourage proper lawn management and landscaping, including use of native vegetation.
- Encourage use of Integrated Pest Management techniques for pest control.
- Encourage proper onsite recycling of yard trimmings.
- Recycle residual paints, solvents, lumber, and other material as much as possible.

## Objectives

- Cover
- Contain
- Educate
- Reduce/Minimize
- Product Substitution

## Targeted Constituents

Sediment	<input checked="" type="checkbox"/>
Nutrients	<input checked="" type="checkbox"/>
Trash	<input checked="" type="checkbox"/>
Metals	<input checked="" type="checkbox"/>
Bacteria	<input checked="" type="checkbox"/>
Oil and Grease	<input checked="" type="checkbox"/>
Organics	<input checked="" type="checkbox"/>
Oxygen Demanding	<input checked="" type="checkbox"/>



# SC-41 Building & Grounds Maintenance

---

## *Suggested Protocols*

### *Pressure Washing of Buildings, Rooftops, and Other Large Objects*

- In situations where soaps or detergents are used and the surrounding area is paved, pressure washers must use a waste water collection device that enables collection of wash water and associated solids. A sump pump, wet vacuum or similarly effective device must be used to collect the runoff and loose materials. The collected runoff and solids must be disposed of properly.
- If soaps or detergents are not used, and the surrounding area is paved, wash water runoff does not have to be collected but must be screened. Pressure washers must use filter fabric or some other type of screen on the ground and/or in the catch basin to trap the particles in wash water runoff.
- If you are pressure washing on a grassed area (with or without soap), runoff must be dispersed as sheet flow as much as possible, rather than as a concentrated stream. The wash runoff must remain on the grass and not drain to pavement. Ensure that this practice does not kill grass.

### *Landscaping Activities*

- Do not apply any chemicals (insecticide, herbicide, or fertilizer) directly to surface waters, unless the application is approved and permitted by the state.
- Dispose of grass clippings, leaves, sticks, or other collected vegetation as garbage, or by composting. Do not dispose of collected vegetation into waterways or storm drainage systems.
- Use mulch or other erosion control measures on exposed soils.
- Check irrigation schedules so pesticides will not be washed away and to minimize non-stormwater discharge.

### *Building Repair, Remodeling, and Construction*

- Do not dump any toxic substance or liquid waste on the pavement, the ground, or toward a storm drain.
- Use ground or drop cloths underneath outdoor painting, scraping, and sandblasting work, and properly dispose of collected material daily.
- Use a ground cloth or oversized tub for activities such as paint mixing and tool cleaning.
- Clean paint brushes and tools covered with water-based paints in sinks connected to sanitary sewers or in portable containers that can be dumped into a sanitary sewer drain. Brushes and tools covered with non-water-based paints, finishes, or other materials must be cleaned in a manner that enables collection of used solvents (e.g., paint thinner, turpentine, etc.) for recycling or proper disposal.

- Use a storm drain cover, filter fabric, or similarly effective runoff control mechanism if dust, grit, wash water, or other pollutants may escape the work area and enter a catch basin. The containment device(s) must be in place at the beginning of the work day, and accumulated dirty runoff and solids must be collected and disposed of before removing the containment device(s) at the end of the work day.
- If you need to de-water an excavation site, you may need to filter the water before discharging to a catch basin or off-site. In which case you should direct the water through hay bales and filter fabric or use other sediment filters or traps.
- Store toxic material under cover with secondary containment during precipitation events and when not in use. A cover would include tarps or other temporary cover material.

### ***Mowing, Trimming, and Planting***

- Dispose of leaves, sticks, or other collected vegetation as garbage, by composting or at a permitted landfill. Do not dispose of collected vegetation into waterways or storm drainage systems.
- Use mulch or other erosion control measures when soils are exposed.
- Place temporarily stockpiled material away from watercourses and drain inlets, and berm or cover stockpiles to prevent material releases to the storm drain system.
- Consider an alternative approach when bailing out muddy water; do not put it in the storm drain, pour over landscaped areas.
- Use hand or mechanical weeding where practical.

### ***Fertilizer and Pesticide Management***

- Follow all federal, state, and local laws and regulations governing the use, storage, and disposal of fertilizers and pesticides and training of applicators and pest control advisors.
- Follow manufacturers' recommendations and label directions. Pesticides must never be applied if precipitation is occurring or predicted. Do not apply insecticides within 100 feet of surface waters such as lakes, ponds, wetlands, and streams.
- Use less toxic pesticides that will do the job, whenever possible. Avoid use of copper-based pesticides if possible.
- Do not use pesticides if rain is expected.
- Do not mix or prepare pesticides for application near storm drains.
- Use the minimum amount needed for the job.
- Calibrate fertilizer distributors to avoid excessive application.
- Employ techniques to minimize off-target application (e.g. spray drift) of pesticides, including consideration of alternative application techniques.

# SC-41 Building & Grounds Maintenance

---

- Apply pesticides only when wind speeds are low.
- Work fertilizers into the soil rather than dumping or broadcasting them onto the surface.
- Irrigate slowly to prevent runoff and then only as much as is needed.
- Clean pavement and sidewalk if fertilizer is spilled on these surfaces before applying irrigation water.
- Dispose of empty pesticide containers according to the instructions on the container label.
- Use up the pesticides. Rinse containers, and use rinse water as product. Dispose of unused pesticide as hazardous waste.
- Implement storage requirements for pesticide products with guidance from the local fire department and County Agricultural Commissioner. Provide secondary containment for pesticides.

## ***Inspection***

- Inspect irrigation system periodically to ensure that the right amount of water is being applied and that excessive runoff is not occurring. Minimize excess watering, and repair leaks in the irrigation system as soon as they are observed.

## ***Training***

- Educate and train employees on use of pesticides and in pesticide application techniques to prevent pollution.
- Train employees and contractors in proper techniques for spill containment and cleanup.
- Be sure the frequency of training takes into account the complexity of the operations and the nature of the staff.

## ***Spill Response and Prevention***

- Refer to SC-11, Spill Prevention, Control & Cleanup
- Keep your Spill Prevention Control and countermeasure (SPCC) plan up-to-date, and implement accordingly.
- Have spill cleanup materials readily available and in a known location.
- Cleanup spills immediately and use dry methods if possible.
- Properly dispose of spill cleanup material.

## ***Other Considerations***

- Alternative pest/weed controls may not be available, suitable, or effective in many cases.

## **Requirements**

### **Costs**

- Overall costs should be low in comparison to other BMPs.

### **Maintenance**

- Sweep paved areas regularly to collect loose particles, and wipe up spills with rags and other absorbent material immediately, do not hose down the area to a storm drain.

## **Supplemental Information**

### ***Further Detail of the BMP***

#### ***Fire Sprinkler Line Flushing***

Building fire sprinkler line flushing may be a source of non-stormwater runoff pollution. The water entering the system is usually potable water though in some areas it may be non-potable reclaimed wastewater. There are subsequent factors that may drastically reduce the quality of the water in such systems. Black iron pipe is usually used since it is cheaper than potable piping but it is subject to rusting and results in lower quality water. Initially the black iron pipe has an oil coating to protect it from rusting between manufacture and installation; this will contaminate the water from the first flush but not from subsequent flushes. Nitrates, poly-phosphates and other corrosion inhibitors, as well as fire suppressants and antifreeze may be added to the sprinkler water system. Water generally remains in the sprinkler system a long time, typically a year, between flushes and may accumulate iron, manganese, lead, copper, nickel and zinc. The water generally becomes anoxic and contains living and dead bacteria and breakdown products from chlorination. This may result in a significant BOD problem and the water often smells. Consequently dispose fire sprinkler line flush water into the sanitary sewer. Do not allow discharge to storm drain or infiltration due to potential high levels of pollutants in fire sprinkler line water.

## **References and Resources**

California's Nonpoint Source Program Plan <http://www.swrcb.ca.gov/nps/index.html>

King County - <ftp://dnr.metrokc.gov/wlr/dss/spcm/Chapter%203.PDF>

Orange County Stormwater Program

[http://www.ocwatersheds.com/StormWater/swp\\_introduction.asp](http://www.ocwatersheds.com/StormWater/swp_introduction.asp)

Mobile Cleaners Pilot Program: Final Report. 1997. Bay Area Stormwater Management Agencies Association (BASSMA) <http://www.basmaa.org/>

Pollution from Surface Cleaning Folder. 1996. Bay Area Stormwater Management Agencies Association (BASMAA) <http://www.basmaa.org/>

San Diego Stormwater Co-permittees Jurisdictional Urban Runoff Management Program (URMP) -

<http://www.projectcleanwater.org/pdf/Model%20Program%20Municipal%20Facilities.pdf>



## Objectives

- Cover
- Contain
- Educate
- Reduce/Minimize

## Description

As a consequence of its function, the stormwater conveyance system collects and transports urban runoff and stormwater that may contain certain pollutants. The protocols in this fact sheet are intended to reduce pollutants reaching receiving waters through proper conveyance system operation and maintenance.

## Approach

### *Pollution Prevention*

Maintain catch basins, stormwater inlets, and other stormwater conveyance structures on a regular basis to remove pollutants, reduce high pollutant concentrations during the first flush of storms, prevent clogging of the downstream conveyance system, restore catch basins' sediment trapping capacity, and ensure the system functions properly hydraulically to avoid flooding.

### *Suggested Protocols*

#### *Catch Basins/Inlet Structures*

- Staff should regularly inspect facilities to ensure compliance with the following:
  - Immediate repair of any deterioration threatening structural integrity.
  - Cleaning before the sump is 40% full. Catch basins should be cleaned as frequently as needed to meet this standard.
  - Stenciling of catch basins and inlets (see SC34 Waste Handling and Disposal).

## Targeted Constituents

Sediment	✓
Nutrients	
Trash	✓
Metals	
Bacteria	✓
Oil and Grease	
Organics	



- Clean catch basins, storm drain inlets, and other conveyance structures before the wet season to remove sediments and debris accumulated during the summer.
- Conduct inspections more frequently during the wet season for problem areas where sediment or trash accumulates more often. Clean and repair as needed.
- Keep accurate logs of the number of catch basins cleaned.
- Store wastes collected from cleaning activities of the drainage system in appropriate containers or temporary storage sites in a manner that prevents discharge to the storm drain.
- Dewater the wastes if necessary with outflow into the sanitary sewer if permitted. Water should be treated with an appropriate filtering device prior to discharge to the sanitary sewer. If discharge to the sanitary sewer is not allowed, water should be pumped or vacuumed to a tank and properly disposed. Do not dewater near a storm drain or stream.

#### *Storm Drain Conveyance System*

- Locate reaches of storm drain with deposit problems and develop a flushing schedule that keeps the pipe clear of excessive buildup.
- Collect and pump flushed effluent to the sanitary sewer for treatment whenever possible.

#### *Pump Stations*

- Clean all storm drain pump stations prior to the wet season to remove silt and trash.
- Do not allow discharge to reach the storm drain system when cleaning a storm drain pump station or other facility.
- Conduct routine maintenance at each pump station.
- Inspect, clean, and repair as necessary all outlet structures prior to the wet season.

#### *Open Channel*

- Modify storm channel characteristics to improve channel hydraulics, increase pollutant removals, and enhance channel/creek aesthetic and habitat value.
- Conduct channel modification/improvement in accordance with existing laws. Any person, government agency, or public utility proposing an activity that will change the natural (emphasis added) state of any river, stream, or lake in California, must enter into a Stream or Lake Alteration Agreement with the Department of Fish and Game. The developer-applicant should also contact local governments (city, county, special districts), other state agencies (SWRCB, RWQCB, Department of Forestry, Department of Water Resources), and Federal Corps of Engineers and USFWS.

#### *Illicit Connections and Discharges*

- Look for evidence of illegal discharges or illicit connections during routine maintenance of conveyance system and drainage structures:
  - Is there evidence of spills such as paints, discoloring, etc?

- Are there any odors associated with the drainage system?
- Record locations of apparent illegal discharges/illicit connections?
- Track flows back to potential dischargers and conduct aboveground inspections. This can be done through visual inspection of upgradient manholes or alternate techniques including zinc chloride smoke testing, fluorometric dye testing, physical inspection testing, or television camera inspection.
- Eliminate the discharge once the origin of flow is established.
- Stencil or demarcate storm drains, where applicable, to prevent illegal disposal of pollutants. Storm drain inlets should have messages such as “Dump No Waste Drains to Stream” stenciled next to them to warn against ignorant or intentional dumping of pollutants into the storm drainage system.
- Refer to fact sheet SC-10 Non-Stormwater Discharges.

### *Illegal Dumping*

- Inspect and clean up hot spots and other storm drainage areas regularly where illegal dumping and disposal occurs.
- Establish a system for tracking incidents. The system should be designed to identify the following:
  - Illegal dumping hot spots
  - Types and quantities (in some cases) of wastes
  - Patterns in time of occurrence (time of day/night, month, or year)
  - Mode of dumping (abandoned containers, “midnight dumping” from moving vehicles, direct dumping of materials, accidents/spills)
  - Responsible parties
- Post “No Dumping” signs in problem areas with a phone number for reporting dumping and disposal. Signs should also indicate fines and penalties for illegal dumping.
- Refer to fact sheet SC-10 Non-Stormwater Discharges.

### *Training*

- Train crews in proper maintenance activities, including record keeping and disposal.
- Allow only properly trained individuals to handle hazardous materials/wastes.
- Have staff involved in detection and removal of illicit connections trained in the following:
  - OSHA-required Health and Safety Training (29 CFR 1910.120) plus annual refresher training (as needed).



- OSHA Confined Space Entry training (Cal-OSHA Confined Space, Title 8 and Federal OSHA 29 CFR 1910.146).
- Procedural training (field screening, sampling, smoke/dye testing, TV inspection).

***Spill Response and Prevention***

- Investigate all reports of spills, leaks, and/or illegal dumping promptly.
- Clean up all spills and leaks using “dry” methods (with absorbent materials and/or rags) or dig up, remove, and properly dispose of contaminated soil.
- Refer to fact sheet SC-11 Spill Prevention, Control, and Cleanup.

***Other Considerations (Limitations and Regulations)***

- Clean-up activities may create a slight disturbance for local aquatic species. Access to items and material on private property may be limited. Trade-offs may exist between channel hydraulics and water quality/riparian habitat. If storm channels or basins are recognized as wetlands, many activities, including maintenance, may be subject to regulation and permitting.
- Storm drain flushing is most effective in small diameter pipes (36-inch diameter pipe or less, depending on water supply and sediment collection capacity). Other considerations associated with storm drain flushing may include the availability of a water source, finding a downstream area to collect sediments, liquid/sediment disposal, and prohibition against disposal of flushed effluent to sanitary sewer in some areas.
- Regulations may include adoption of substantial penalties for illegal dumping and disposal.
- Local municipal codes may include sections prohibiting discharge of soil, debris, refuse, hazardous wastes, and other pollutants into the storm drain system.

**Requirements*****Costs***

- An aggressive catch basin cleaning program could require a significant capital and O&M budget.
- The elimination of illegal dumping is dependent on the availability, convenience, and cost of alternative means of disposal. The primary cost is for staff time. Cost depends on how aggressively a program is implemented. Other cost considerations for an illegal dumping program include:
  - Purchase and installation of signs.
  - Rental of vehicle(s) to haul illegally-disposed items and material to landfills.
  - Rental of heavy equipment to remove larger items (e.g., car bodies) from channels.
  - Purchase of landfill space to dispose of illegally-dumped items and material.

- Methods used for illicit connection detection (smoke testing, dye testing, visual inspection, and flow monitoring) can be costly and time-consuming. Site-specific factors, such as the level of impervious area, the density and ages of buildings, and type of land use will determine the level of investigation necessary.

## *Maintenance*

- Two-person teams may be required to clean catch basins with vactor trucks.
- Teams of at least two people plus administrative personnel are required to identify illicit discharges, depending on the complexity of the storm sewer system.
- Arrangements must be made for proper disposal of collected wastes.
- Technical staff are required to detect and investigate illegal dumping violations.

## Supplemental Information

### *Further Detail of the BMP*

#### *Storm Drain Flushing*

Flushing is a common maintenance activity used to improve pipe hydraulics and to remove pollutants in storm drainage systems. Flushing may be designed to hydraulically convey accumulated material to strategic locations, such as an open channel, another point where flushing will be initiated, or the sanitary sewer and the treatment facilities, thus preventing resuspension and overflow of a portion of the solids during storm events. Flushing prevents “plug flow” discharges of concentrated pollutant loadings and sediments. Deposits can hinder the designed conveyance capacity of the storm drain system and potentially cause backwater conditions in severe cases of clogging.

Storm drain flushing usually takes place along segments of pipe with grades that are too flat to maintain adequate velocity to keep particles in suspension. An upstream manhole is selected to place an inflatable device that temporarily plugs the pipe. Further upstream, water is pumped into the line to create a flushing wave. When the upstream reach of pipe is sufficiently full to cause a flushing wave, the inflated device is rapidly deflated with the assistance of a vacuum pump, thereby releasing the backed up water and resulting in the cleaning of the storm drain segment.

To further reduce impacts of stormwater pollution, a second inflatable device placed well downstream may be used to recollect the water after the force of the flushing wave has dissipated. A pump may then be used to transfer the water and accumulated material to the sanitary sewer for treatment. In some cases, an interceptor structure may be more practical or required to recollect the flushed waters.

It has been found that cleansing efficiency of periodic flush waves is dependent upon flush volume, flush discharge rate, sewer slope, sewer length, sewer flow rate, sewer diameter, and population density. As a rule of thumb, the length of line to be flushed should not exceed 700 feet. At this maximum recommended length, the percent removal efficiency ranges between 65-75% for organics and 55-65% for dry weather grit/inorganic material. The percent removal efficiency drops rapidly beyond that. Water is commonly supplied by a water truck, but fire hydrants can also supply water. To make the best use of water, it is recommended that reclaimed water be used or that fire hydrant line flushing coincide with storm sewer flushing.

# SC-44      Drainage System Maintenance

---

## References and Resources

California's Nonpoint Source Program Plan <http://www.swrcb.ca.gov/nps/index.html>

Clark County Storm Water Pollution Control Manual  
<http://www.co.clark.wa.us/pubworks/bmpman.pdf>

Ferguson, B.K. 1991. Urban Stream Reclamation, p. 324-322, Journal of Soil and Water Conservation.

King County Storm Water Pollution Control Manual <http://dnr.metrokc.gov/wlr/dss/spcm.htm>

Oregon Association of Clean Water Agencies. Oregon Municipal Stormwater Toolbox for Maintenance Practices. June 1998.

Santa Clara Valley Urban Runoff Pollution Prevention Program <http://www.scvurppp.org>

The Storm Water Managers Resource Center <http://www.stormwatercenter.net>

United States Environmental Protection Agency (USEPA). 2002. Pollution Prevention/Good Housekeeping for Municipal Operations Storm Drain System Cleaning. On line:  
[http://www.epa.gov/npdes/menuofbmps/poll\\_16.htm](http://www.epa.gov/npdes/menuofbmps/poll_16.htm)



## Design Considerations

- Accumulation of Metals
- Clogged Soil Outlet Structures
- Vegetation/Landscape Maintenance

## Description

An infiltration trench is a long, narrow, rock-filled trench with no outlet that receives stormwater runoff. Runoff is stored in the void space between the stones and infiltrates through the bottom and into the soil matrix. Infiltration trenches perform well for removal of fine sediment and associated pollutants.

Pretreatment using buffer strips, swales, or detention basins is important for limiting amounts of coarse sediment entering the trench which can clog and render the trench ineffective.

## California Experience

Caltrans constructed two infiltration trenches at highway maintenance stations in Southern California. Of these, one failed to operate to the design standard because of average soil infiltration rates lower than that measured in the single infiltration test. This highlights the critical need for appropriate evaluation of the site. Once in operation, little maintenance was required at either site.

## Advantages

- Provides 100% reduction in the load discharged to surface waters.
- An important benefit of infiltration trenches is the approximation of pre-development hydrology during which a significant portion of the average annual rainfall runoff is infiltrated rather than flushed directly to creeks.
- If the water quality volume is adequately sized, infiltration trenches can be useful for providing control of channel forming (erosion) and high frequency (generally less than the 2-year) flood events.

## Targeted Constituents

<input checked="" type="checkbox"/>	Sediment	■
<input checked="" type="checkbox"/>	Nutrients	■
<input checked="" type="checkbox"/>	Trash	■
<input checked="" type="checkbox"/>	Metals	■
<input checked="" type="checkbox"/>	Bacteria	■
<input checked="" type="checkbox"/>	Oil and Grease	■
<input checked="" type="checkbox"/>	Organics	■

## Legend (Removal Effectiveness)

- Low
- High
- ▲ Medium



- As an underground BMP, trenches are unobtrusive and have little impact of site aesthetics.

## Limitations

- Have a high failure rate if soil and subsurface conditions are not suitable.
- May not be appropriate for industrial sites or locations where spills may occur.
- The maximum contributing area to an individual infiltration practice should generally be less than 5 acres.
- Infiltration basins require a minimum soil infiltration rate of 0.5 inches/hour, not appropriate at sites with Hydrologic Soil Types C and D.
- If infiltration rates exceed 2.4 inches/hour, then the runoff should be fully treated prior to infiltration to protect groundwater quality.
- Not suitable on fill sites or steep slopes.
- Risk of groundwater contamination in very coarse soils.
- Upstream drainage area must be completely stabilized before construction.
- Difficult to restore functioning of infiltration trenches once clogged.

## Design and Sizing Guidelines

- Provide pretreatment for infiltration trenches in order to reduce the sediment load. Pretreatment refers to design features that provide settling of large particles before runoff reaches a management practice, easing the long-term maintenance burden. Pretreatment is important for all structural stormwater management practices, but it is particularly important for infiltration practices. To ensure that pretreatment mechanisms are effective, designers should incorporate practices such as grassed swales, vegetated filter strips, detention, or a plunge pool in series.
- Specify locally available trench rock that is 1.5 to 2.5 inches in diameter.
- Determine the trench volume by assuming the WQV will fill the void space based on the computed porosity of the rock matrix (normally about 35%).
- Determine the bottom surface area needed to drain the trench within 72 hr by dividing the WQV by the infiltration rate.

$$d = \frac{WQV + RFV}{SA}$$

- Calculate trench depth using the following equation:

where:

D = Trench depth

WQV	=	Water quality volume
RFV	=	Rock fill volume
SA	=	Surface area of the trench bottom

- The use of vertical piping, either for distribution or infiltration enhancement shall not be allowed to avoid device classification as a Class V injection well per 40 CFR146.5(e)(4).
- Provide observation well to allow observation of drain time.
- May include a horizontal layer of filter fabric just below the surface of the trench to retain sediment and reduce the potential for clogging.

### ***Construction/Inspection Considerations***

Stabilize the entire area draining to the facility before construction begins. If impossible, place a diversion berm around the perimeter of the infiltration site to prevent sediment entrance during construction. Stabilize the entire contributing drainage area before allowing any runoff to enter once construction is complete.

### **Performance**

Infiltration trenches eliminate the discharge of the water quality volume to surface receiving waters and consequently can be considered to have 100% removal of all pollutants within this volume. Transport of some of these constituents to groundwater is likely, although the attenuation in the soil and subsurface layers will be substantial for many constituents.

Infiltration trenches can be expected to remove up to 90 percent of sediments, metals, coliform bacteria and organic matter, and up to 60 percent of phosphorus and nitrogen in the infiltrated runoff (Schueler, 1992). Biochemical oxygen demand (BOD) removal is estimated to be between 70 to 80 percent. Lower removal rates for nitrate, chlorides and soluble metals should be expected, especially in sandy soils (Schueler, 1992). Pollutant removal efficiencies may be improved by using washed aggregate and adding organic matter and loam to the subsoil. The stone aggregate should be washed to remove dirt and fines before placement in the trench. The addition of organic material and loam to the trench subsoil may enhance metals removal through adsorption.

### **Siting Criteria**

The use of infiltration trenches may be limited by a number of factors, including type of native soils, climate, and location of groundwater table. Site characteristics, such as excessive slope of the drainage area, fine-grained soil types, and proximate location of the water table and bedrock, may preclude the use of infiltration trenches. Generally, infiltration trenches are not suitable for areas with relatively impermeable soils containing clay and silt or in areas with fill.

As with any infiltration BMP, the potential for groundwater contamination must be carefully considered, especially if the groundwater is used for human consumption or agricultural purposes. The infiltration trench is not suitable for sites that use or store chemicals or hazardous materials unless hazardous and toxic materials are prevented from entering the trench. In these areas, other BMPs that do not allow interaction with the groundwater should be considered.

The potential for spills can be minimized by aggressive pollution prevention measures. Many municipalities and industries have developed comprehensive spill prevention control and countermeasure (SPCC) plans. These plans should be modified to include the infiltration trench and the contributing drainage area. For example, diversion structures can be used to prevent spills from entering the infiltration trench. Because of the potential to contaminate groundwater, extensive site investigation must be undertaken early in the site planning process to establish site suitability for the installation of an infiltration trench.

Longevity can be increased by careful geotechnical evaluation prior to construction and by designing and implementing an inspection and maintenance plan. Soil infiltration rates and the water table depth should be evaluated to ensure that conditions are satisfactory for proper operation of an infiltration trench. Pretreatment structures, such as a vegetated buffer strip or water quality inlet, can increase longevity by removing sediments, hydrocarbons, and other materials that may clog the trench. Regular maintenance, including the replacement of clogged aggregate, will also increase the effectiveness and life of the trench.

Evaluation of the viability of a particular site is the same as for infiltration basins and includes:

- Determine soil type (consider RCS soil type 'A, B or C' only) from mapping and consult USDA soil survey tables to review other parameters such as the amount of silt and clay, presence of a restrictive layer or seasonal high water table, and estimated permeability. The soil should not have more than 30 percent clay or more than 40 percent of clay and silt combined. Eliminate sites that are clearly unsuitable for infiltration.
- Groundwater separation should be at least 3 m from the basin invert to the measured ground water elevation. There is concern at the state and regional levels of the impact on groundwater quality from infiltrated runoff, especially when the separation between groundwater and the surface is small.
- Location away from buildings, slopes and highway pavement (greater than 6 m) and wells and bridge structures (greater than 30 m). Sites constructed of fill, having a base flow or with a slope greater than 15 percent should not be considered.
- Ensure that adequate head is available to operate flow splitter structures (to allow the basin to be offline) without ponding in the splitter structure or creating backwater upstream of the splitter.
- Base flow should not be present in the tributary watershed.

### ***Secondary Screening Based on Site Geotechnical Investigation***

- At least three in-hole conductivity tests shall be performed using USBR 7300-89 or Bouwer-Rice procedures (the latter if groundwater is encountered within the boring), two tests at different locations within the proposed basin and the third down gradient by no more than approximately 10 m. The tests shall measure permeability in the side slopes and the bed within a depth of 3 m of the invert.
- The minimum acceptable hydraulic conductivity as measured in any of the three required test holes is 13 mm/hr. If any test hole shows less than the minimum value, the site should be disqualified from further consideration.

- Exclude from consideration sites constructed in fill or partially in fill unless no silts or clays are present in the soil boring. Fill tends to be compacted, with clays in a dispersed rather than flocculated state, greatly reducing permeability.
- The geotechnical investigation should be such that a good understanding is gained as to how the stormwater runoff will move in the soil (horizontally or vertically) and if there are any geological conditions that could inhibit the movement of water.

## Maintenance

Infiltration trenches required the least maintenance of any of the BMPs evaluated in the Caltrans study, with approximately 17 field hours spent on the operation and maintenance of each site. Inspection of the infiltration trench was the largest field activity, requiring approximately 8 hr/yr.

In addition to reduced water quality performance, clogged infiltration trenches with surface standing water can become a nuisance due to mosquito breeding. If the trench takes more than 72 hours to drain, then the rock fill should be removed and all dimensions of the trench should be increased by 2 inches to provide a fresh surface for infiltration.

## Cost

### Construction Cost

Infiltration trenches are somewhat expensive, when compared to other stormwater practices, in terms of cost per area treated. Typical construction costs, including contingency and design costs, are about \$5 per ft<sup>3</sup> of stormwater treated (SWRPC, 1991; Brown and Schueler, 1997). Actual construction costs may be much higher. The average construction cost of two infiltration trenches installed by Caltrans in southern California was about \$50/ft<sup>3</sup>; however, these were constructed as retrofit installations.

Infiltration trenches typically consume about 2 to 3 percent of the site draining to them, which is relatively small. In addition, infiltration trenches can fit into thin, linear areas. Thus, they can generally fit into relatively unusable portions of a site.

### Maintenance Cost

One cost concern associated with infiltration practices is the maintenance burden and longevity. If improperly sited or maintained, infiltration trenches have a high failure rate. In general, maintenance costs for infiltration trenches are estimated at between 5 percent and 20 percent of the construction cost. More realistic values are probably closer to the 20-percent range, to ensure long-term functionality of the practice.

## References and Sources of Additional Information

Caltrans, 2002, BMP Retrofit Pilot Program Proposed Final Report, Rpt. CTSW-RT-01-050, California Dept. of Transportation, Sacramento, CA.

Brown, W., and T. Schueler. 1997. *The Economics of Stormwater BMPs in the Mid-Atlantic Region*. Prepared for the Chesapeake Research Consortium, Edgewater, MD, by the Center for Watershed Protection, Ellicott City, MD.

Galli, J. 1992. *Analysis of Urban BMP Performance and Longevity in Prince George's County, Maryland*. Metropolitan Washington Council of Governments, Washington, DC.



Maryland Department of the Environment (MDE). 2000. **Maryland Stormwater Design Manual**. <http://www.mde.state.md.us/environment/wma/stormwatermanual>. Accessed May 22, 2001.

Metzger, M. E., D. F. Messer, C. L. Beitia, C. M. Myers, and V. L. Kramer. 2002. The Dark Side Of Stormwater Runoff Management: Disease Vectors Associated With Structural BMPs. *Stormwater* 3(2): 24-39.

Schueler, T. 1987. **Controlling Urban Runoff: A Practical Manual for Planning and Designing Urban BMPs**. Metropolitan Washington Council of Governments, Washington, DC.

Southeastern Wisconsin Regional Planning Commission (SWRPC). 1991. **Costs of Urban Nonpoint Source Water Pollution Control Measures**. Southeastern Wisconsin Regional Planning Commission, Waukesha, WI.

Watershed Management Institute (WMI). 1997. **Operation, Maintenance, and Management of Stormwater Management Systems**. Prepared for U.S. Environmental Protection Agency, Office of Water, Washington, DC.

### **Information Resources**

Center for Watershed Protection (CWP). 1997. **Stormwater BMP Design Supplement for Cold Climates**. Prepared for the U.S. Environmental Protection Agency, Office of Wetlands, Oceans and Watersheds, Washington, DC, by the Center for Watershed Protection, Ellicott City, MD.

Ferguson, B.K. 1994. **Stormwater Infiltration**. CRC Press, Ann Arbor, MI.

Minnesota Pollution Control Agency. 1989. **Protecting Water Quality in Urban Areas: Best Management Practices**. Minnesota Pollution Control Agency, Minneapolis, MN.

USEPA. 1993. **Guidance to Specify Management Measures for Sources of Nonpoint Pollution in Coastal Waters**. EPA-840-B-92-002. U.S. Environmental Protection Agency, Office of Water, Washington, DC.

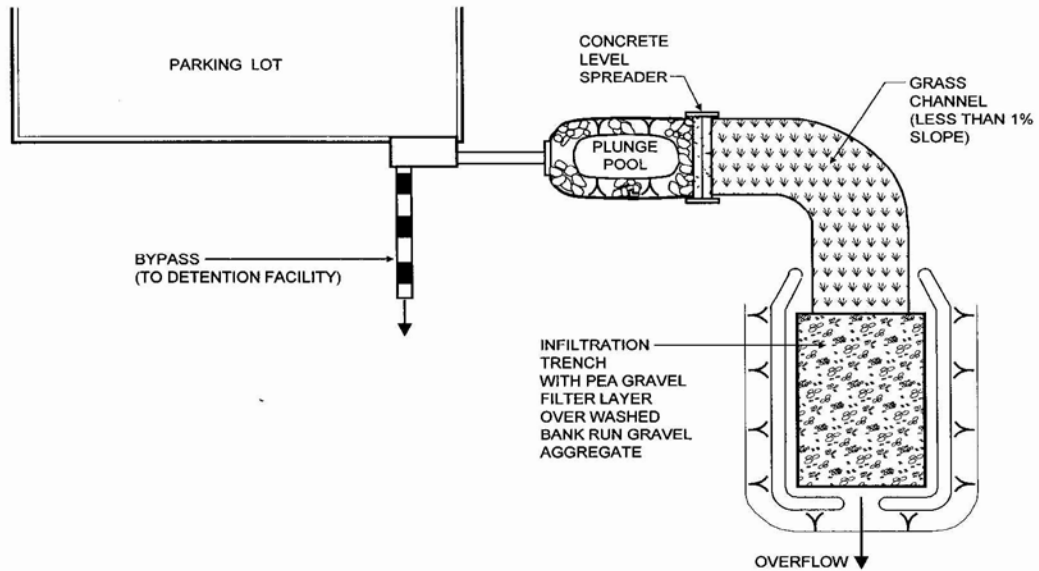

**PLAN VIEW**

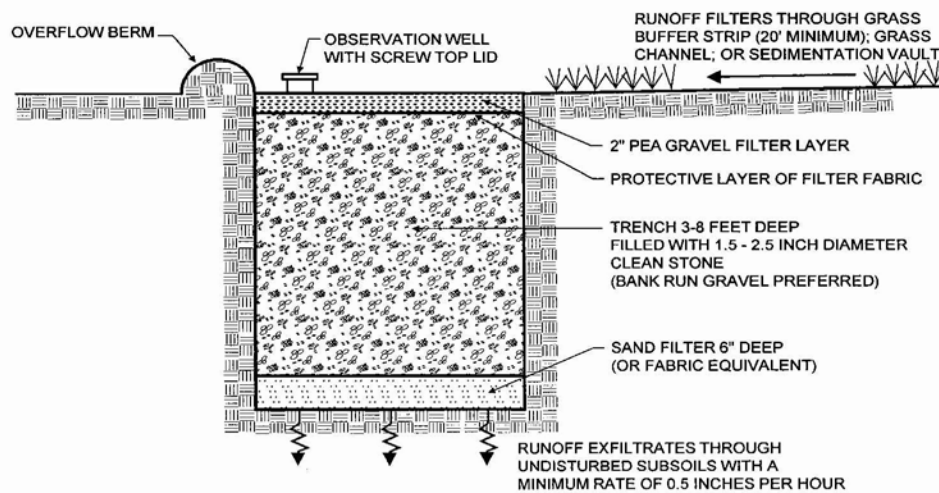

**SECTION**